Contents

5.1 Energy storage system	5-3
5.1.1 Precautions	5-3
5.1.2 Introduction to structure and principle	5-4
5.1.3 Position diagram of parts	5-5
5.1.4 Exploded view of structure	5-6
5.1 Battery system	5-8
5.1.5.1 Removal and refitting of battery pack assembly (REV)	5-8
5.1.5.2 Removal and refitting of battery pack assembly (EV)	5-11
5.2 Electric drive system	5-14
5.2.1 Position diagram of parts	5-14
5.2.2 Exploded view of structure	5-15
5.2.3 Front electric drive system	5-16
5.2.3.1 Removal and refitting of front drive motor assembly (REV)	5-16
5.2.3.2 Removal and refitting of front drive motor assembly (EV)	5-19
5.2.4 Rear electric drive system	5-21
5.2.4.1 Removal and refitting of rear drive motor assembly	5-21
5.3 Vehicle control and management system	5-23
5.3.1 Introduction to structure and principle	5-23
5.3.2 Position diagram of parts	5-24
5.3.3 Exploded view of structure	5-25
5.3.4 VCU	5-26
5.3.4.1 Removal and refitting of VCU assembly	5-26
5.4 HV assembly system	5-28
5.4.1 Precautions	5-28
5.4.2 Position diagram of parts	5-29
5.4.3 Exploded view of structure	5-30
5.4.4 PDU	5-32
5.4.4.1 Removal and refitting of engine compartment PDU assembly (REV)	5-32
5.4.4.2 Removal and refitting of engine compartment PDU assembly (EV)	5-35
5.4.5 Charging socket	5-37
5.4.5.1 Removal and refitting of slow charging socket	5-37
5.4.5.2 Removal and refitting of fast charging socket assembly	5-40
5.4.6 OBC	5-42
5.4.6.1 Removal and refitting of OBC assembly	5-42
5.5 HV harness system	5-44
5.5.1 Precautions	5-44

5.5.2 Layout of parts (REV)	5-46
5.5.3 Layout of parts (EV)	5-47
5.5.4 Exploded view of structure (REV)	5-48
5.5.5 Exploded view of structure (EV)	5-49
5.5.6 Battery pack rear HV harness	5-51
5.5.6.1 Removal and refitting of battery pack rear HV harness assembly (REV)	5-51
5.5.6.2 Removal and refitting of battery pack rear HV harness assembly (EV)	5-53
5.5.7 Front motor HV harness	5-55
5.5.7.1 Removal and refitting of front motor HV harness assembly (REV)	5-55
5.5.7.2 Removal and refitting of front motor HV harness assembly (EV)	5-57
5.5.8 Rear motor HV harness	5-59
5.5.8.1 Removal and refitting of rear motor HV harness assembly	5-59
5.5.9 PTC HV harness	5-61
5.5.9.1 Removal and refitting of A/C PTC HV harness assembly (REV)	5-61
5.5.9.2 Removal and refitting of A/C PTC HV harness assembly 2 (REV)	5-63
5.5.9.3 Removal and refitting of A/C PTC HV harness assembly (EV)	5-65
5.5.9.4 Removal and refitting of engine compartment battery heating PTC - compressor HV harness assembly (EV)	5-67
5.5.9.5 Removal and refitting of battery PTC HV harness assembly	5-70
5.5.10 Compressor HV harness	5-73
5.5.10.1 Removal and refitting of compressor HV harness assembly	5-73
5.5.11 Battery pack front HV harness	5-76
5.5.11.1 Removal and refitting of battery pack front HV harness assembly (REV)	5-76
5.5.11.2 Removal and refitting of battery pack front HV harness assembly (EV)	5-79

5.1 Energy storage system

5.1.1 Precautions

WARNING:

1. Do not reuse the collided high voltage battery. Collision may lead to damage and crack of partial parts inside the high voltage battery, or even short circuit of the high voltage battery and other extreme situations.
2. Prevent the high voltage battery from being soaked, which may lead to internal short circuit, loss of circuit protection function and abnormal chemical reaction of the high voltage battery.
3. Do not bump or hit the high voltage battery during assembly to avoid deformation of the housing and its internal structure, which may lead to loss of protection function of the internal circuit of the high voltage battery.
4. Welding on the housing is prohibited. The applied voltage to the high voltage battery may cause the loss of protection function of its internal circuit.
5. This manual does not necessarily include all items required for vehicle repair and maintenance. It is intended for use by personnel with professional skills and qualifications. Repair or maintenance performed by technicians who have no professional skills or qualifications and rely only on this manual or fail to use appropriate equipment or tools, will cause injury to themselves or the surrounding personnel and damage to customer's vehicle.
6. To avoid damage to vehicle as a result of dangerous operations, please observe the following rules:
 - a. The contents of this manual must be read thoroughly.
 - b. The methods provided in this manual are quite effective for vehicle maintenance and repair. When performing repairs following the procedures prescribed in this manual, always use the SST. In the event of using non-designated special tools and repair methods, you must ensure the safety of the technician before start and make sure no personal injuries or damages to customer's vehicle will be caused.
 - c. If parts need to be replaced, replace parts with the same part number or use equivalent parts. Do not use inferior parts.
 - d. In order to effectively avoid possible personal injury during repair or maintenance, as well as vehicle damage caused by improper operation or potential hazards that may make the vehicle unsafe, you must earnestly observe the "Warning" and "Caution" in this manual. In addition, the contents of "Warning" and "Caution" in this manual are not exaggerated. Violation of these instructions may lead to dangerous consequences.
 - e. All related operations of the HV system (e.g., maintenance, or repair of the electrical system) of the vehicle can only be performed by professionals trained in HV electrical knowledge.
7. Keep the removed high voltage battery away from water or high humidity environment. Water and vapor may lead to reduced insulation and short circuit of the high voltage battery, thereby resulting in risks of electric shock, fire, etc.
8. Improper scrapping or random discarding of the vehicle and its high voltage battery may cause electric shock and other accidents. Therefore, the high voltage battery should be delivered to designated recycling location by an authorized dealer.

5.1.2 Introduction to structure and principle

BMS controller

BMS is used to take control of the battery pack, including battery safety, SOC algorithm, charge and discharge control commands, parameter monitoring, etc.

BMS detects the total voltage, total current, cell voltage, temperature and other information of the battery pack, and sends this information to CAN network.

BMS performs equalization control of the battery pack to ensure proper working of the battery pack.

BMS can carry out thermal management of the battery pack, including heating and cooling control.

Total positive and negative relays

The relay connects or disconnects the battery pack power circuit and check the relay contacts for sticking.

Battery pack control

BMS checks the charging and discharging status of the battery pack, and calculates the battery pack power status. It also controls the charging and discharging status and calculates the power of the battery pack.

The battery pack enables the vehicle to drive, accelerate and decelerate by means of charging and discharging.

The battery pack sensor detects signals such as voltage, current, and temperature, and transmits the signals to VCU.

The battery pack has an insulation detection function.

5.1.3 Position diagram of parts

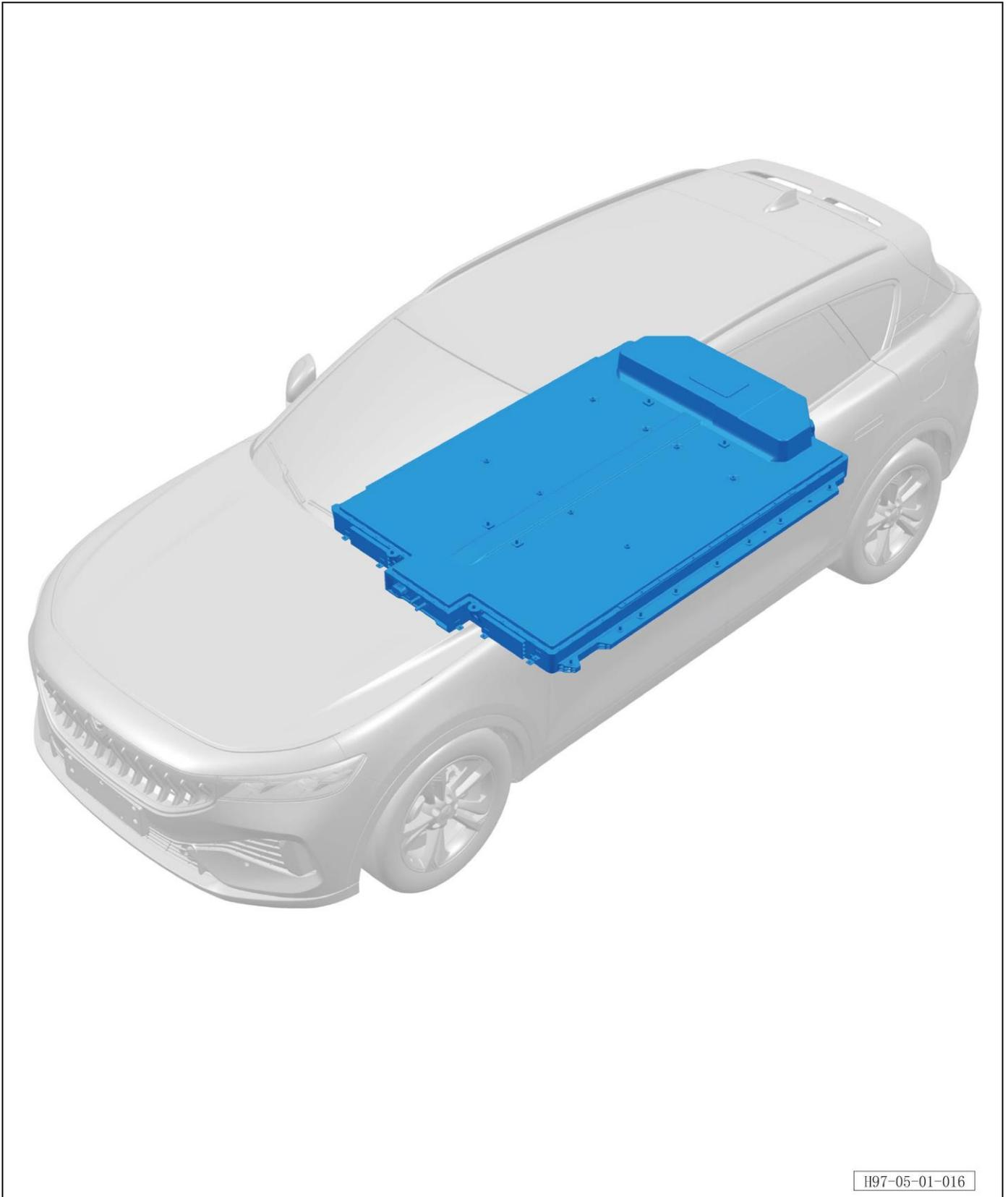

H97-05-01-016

5.1.4 Exploded view

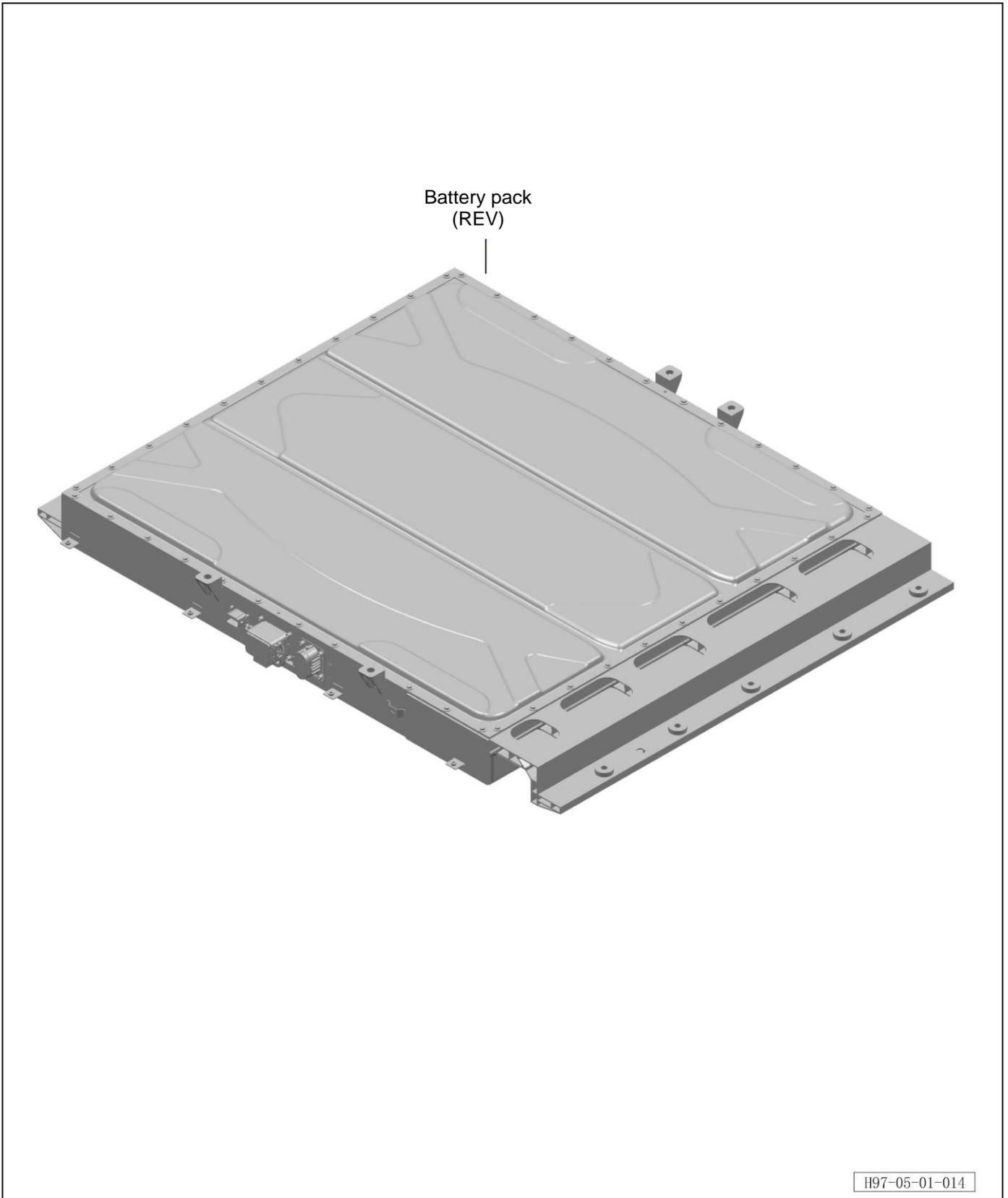

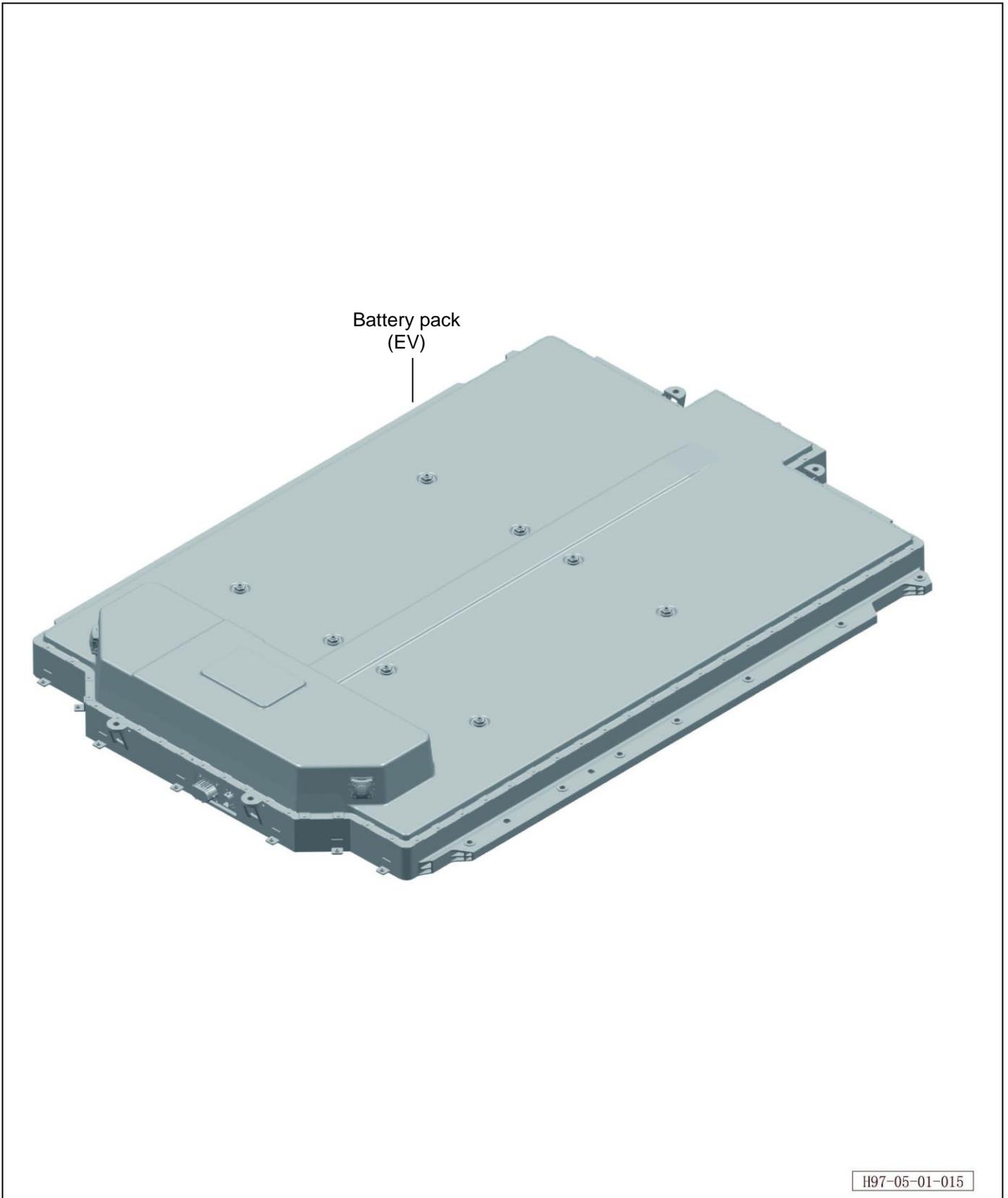

5.1.5 Battery system

5.1.5.1 Removal and refitting of battery pack assembly (REV)

Removal procedure

NOTE:

- Take note of warnings and instructions for maintenance of the HV system. For details, refer to [5.5.1 Warnings and instructions for operations related to HV electronic control system](#).

- The following is the removal and refitting steps of hybrid vehicles.

1. Turn off all electrical appliances and the start switch.

2. Disconnect the battery negative terminal. Refer to [3.1.6.1 Maintenance and inspection battery](#)

3. Lift the vehicle.

4. Discharge drive motor and high voltage battery coolant (refer to [3.1.4.7 Change of drive motor and high voltage battery coolant \(REV\)](#))

5. Remove the middle lower protective plate (refer to [8.6.4.5 Removal and refitting of middle lower protective plate \(REV\)](#))

6. Remove front muffler assembly (refer to [8.2.10.1 Removal and refitting of middle lower protective plate \(REV\)](#))

7. Remove battery pack assembly.

a. Unscrew the fixing bolt A of the battery pack ground harness, and disconnect the battery pack ground harness.

Tightening torque of bolt: $8\pm 1\text{Nm}$.

b. Disconnect the connector B between the generator controller HV harness and the battery pack assembly.

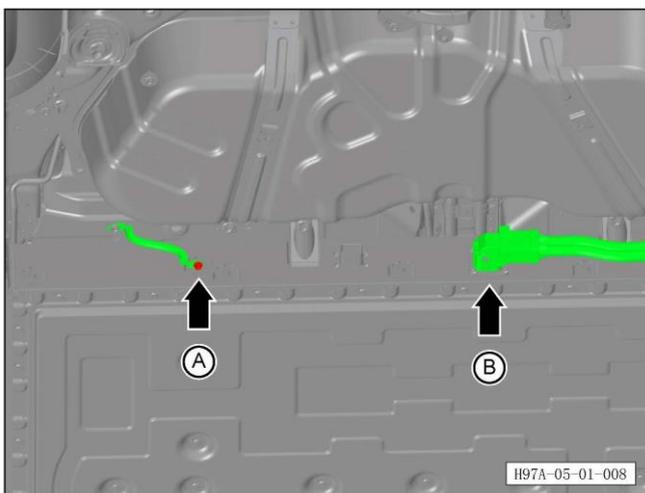

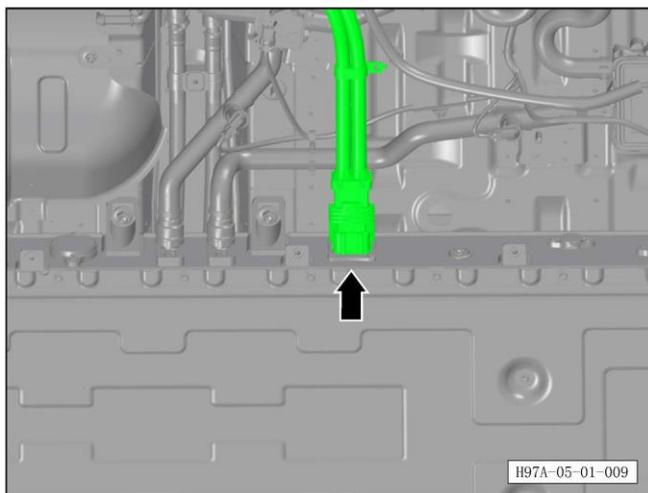

c. Disconnect the connector between the body harness assembly and the battery pack assembly.

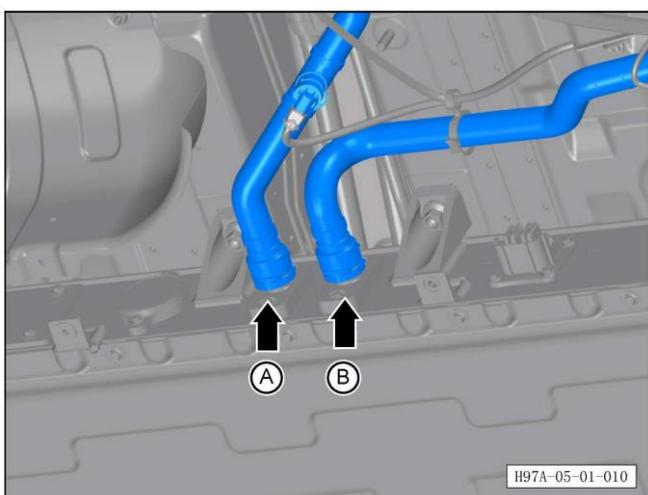

d. Place the coolant collection container at the bottom of the vehicle.

e. Loosen 2 clamps, disconnect the battery pack water inlet pipe A and the battery pack water inlet pipe B, and drain the battery pack coolant.

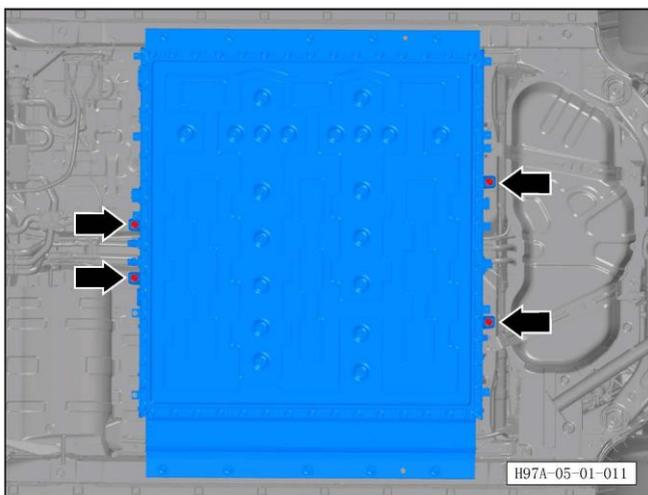

f. Use a lift truck to support the battery pack assembly from under the vehicle.

g. Unscrew 4 fixing bolts at the front and rear parts of the battery pack.

Tightening torque of bolt: (80 ± 5) Nm.

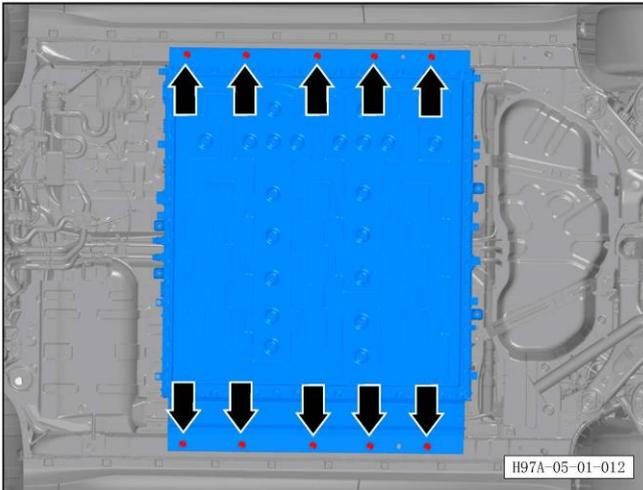

- h. Unscrew 10 fixing bolts on both sides of the battery pack and remove the battery pack assembly.
Tightening torque of bolt: (80 ± 5) Nm.

Refitting procedure

The refitting procedure is performed in reverse order.

CAUTION:

- Coolant cannot be reused, mixed or replaced with that of different colors. Check whether the coolant level is between the MAX (highest) and MIN (lowest) marks and tighten the motor auxiliary tank cover.

5.1.5.2 Removal and refitting of battery pack assembly (EV)

Removal procedure

NOTE

- Take note of warnings and instructions for maintenance of the HV system. For details, refer to [5.5.1 Warnings and instructions for operations related to HV electronic control system](#).

1. Turn off all electrical appliances and the start switch.

2. Disconnect the battery negative terminal (refer to [3.1.6.1 Maintenance and inspection of battery](#))

3. Lift the vehicle.

4. Discharge drive motor and high voltage battery coolant (refer to [3.1.4.8 Change of drive motor and high voltage battery coolant \(EV\)](#))

5. Remove battery pack assembly.

a. Unscrew the fixing bolt A of the battery pack ground harness, and disconnect the battery pack ground harness.

Tightening torque of bolt: (8 ± 5) Nm.

b. Disconnect the connector B between the generator controller HV harness and the battery pack assembly.

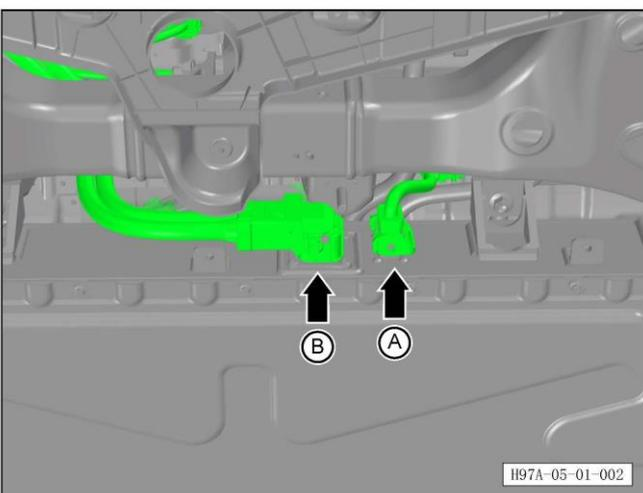
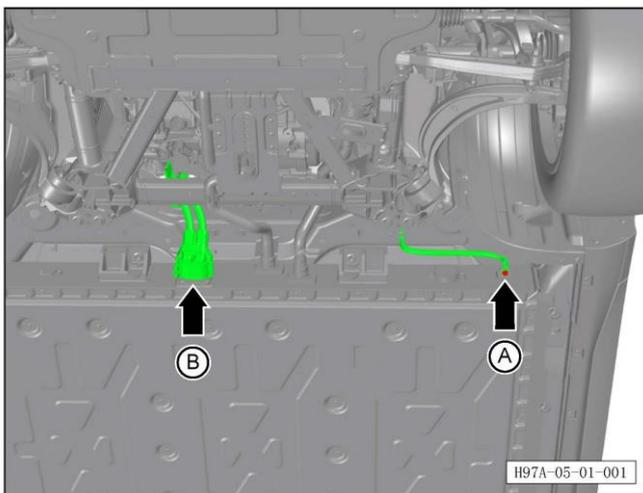

a. Disconnect the connector of rear HV harness A and chassis harness B.

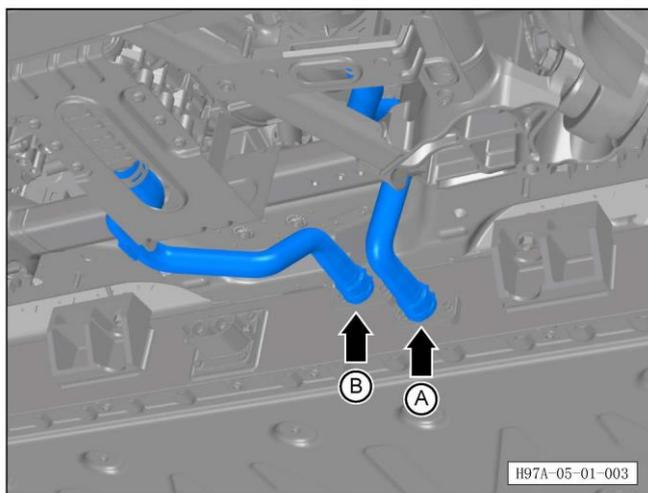

d. Disconnect the battery pack inflow tube A and the battery pack outflow tube B.

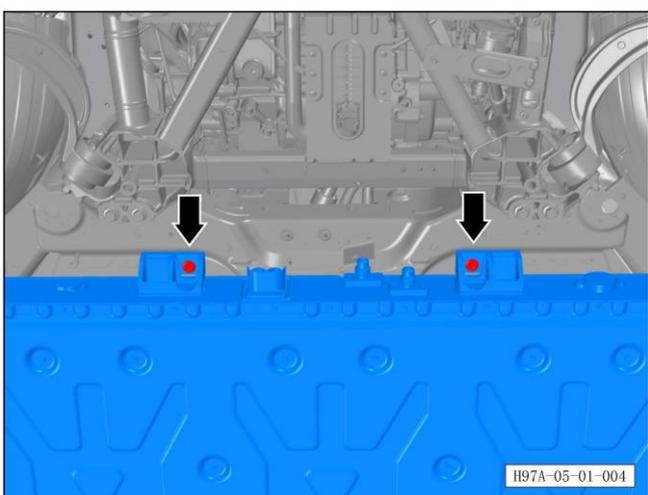

e. Unscrew 2 fixing bolts at front end of the battery pack.

Tightening torque of bolt: (100 ± 10) Nm.

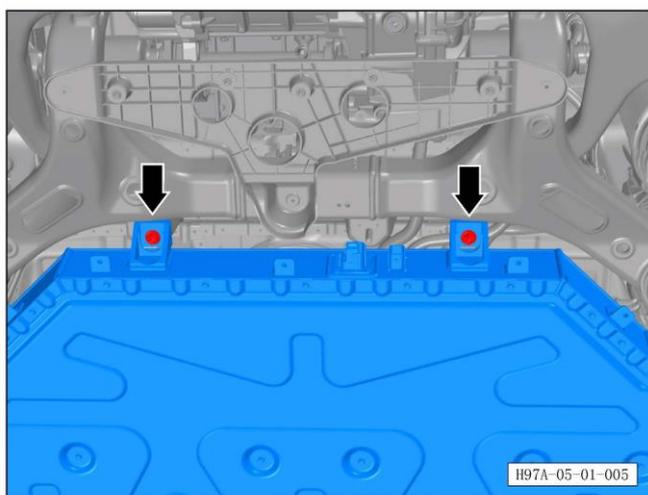

f. Unscrew 2 fixing bolts at rear end of the battery pack.

Tightening torque of bolt: 100 ± 10 Nm.

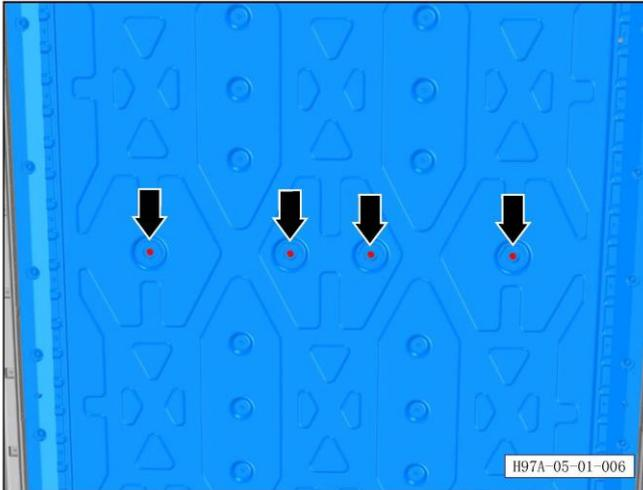

- g. Use a lift cart to support the battery pack assembly.
 h. Unscrew 4 fixing bolts in the middle of the battery pack.

Tightening torque of bolt: $30\pm 3\text{Nm}$.

Note:

- More than two technicians should cooperate to complete this step.

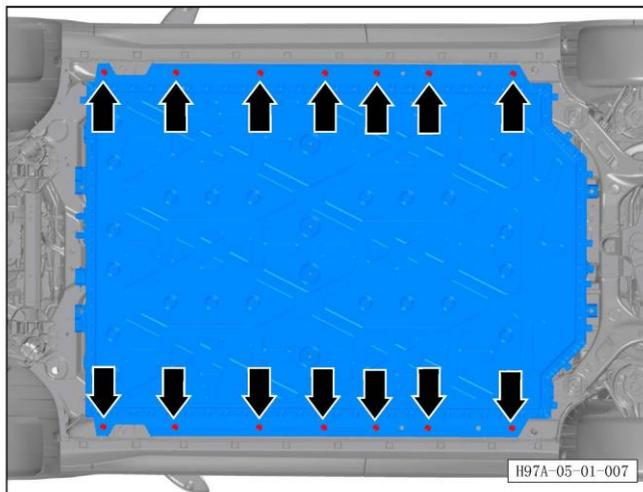

- i. Unscrew 14 fixing bolts on both sides of the battery pack and remove the battery pack assembly.

Tightening torque of bolt: $(100\pm 10)\text{Nm}$.

Refitting procedure

The refitting procedure is performed in reverse order.

CAUTION:

- Coolant cannot be reused, mixed or replaced with that of different colors.
- Fill coolant to the required position and close the water reservoir end cover.
- Coolant recovery must be handled in accordance with relevant national regulations.
- Connect battery negative terminal.

5.2 Electric drive system

5.2.1 Position diagram of parts

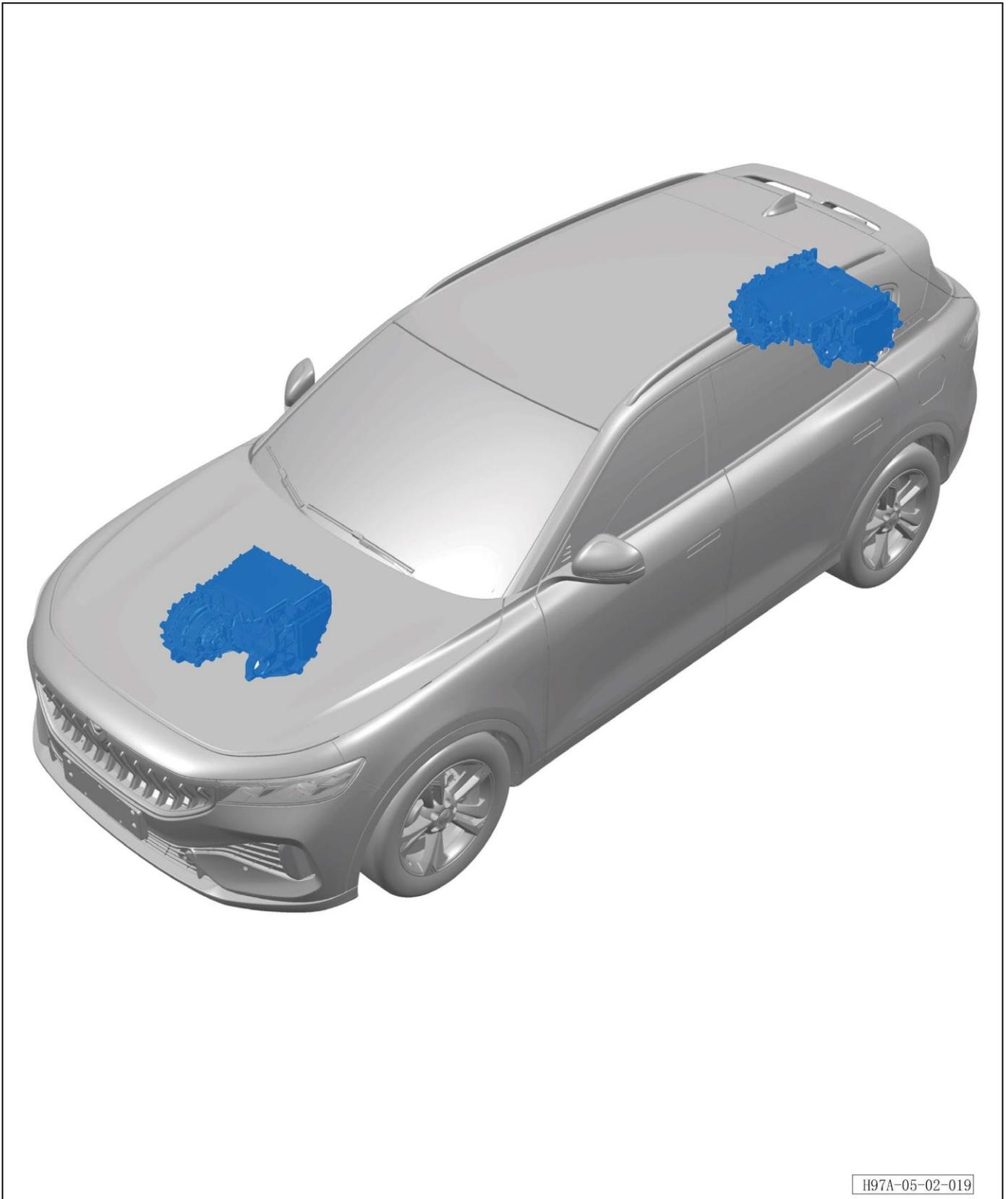

H97A-05-02-019

5.2.2 Exploded view

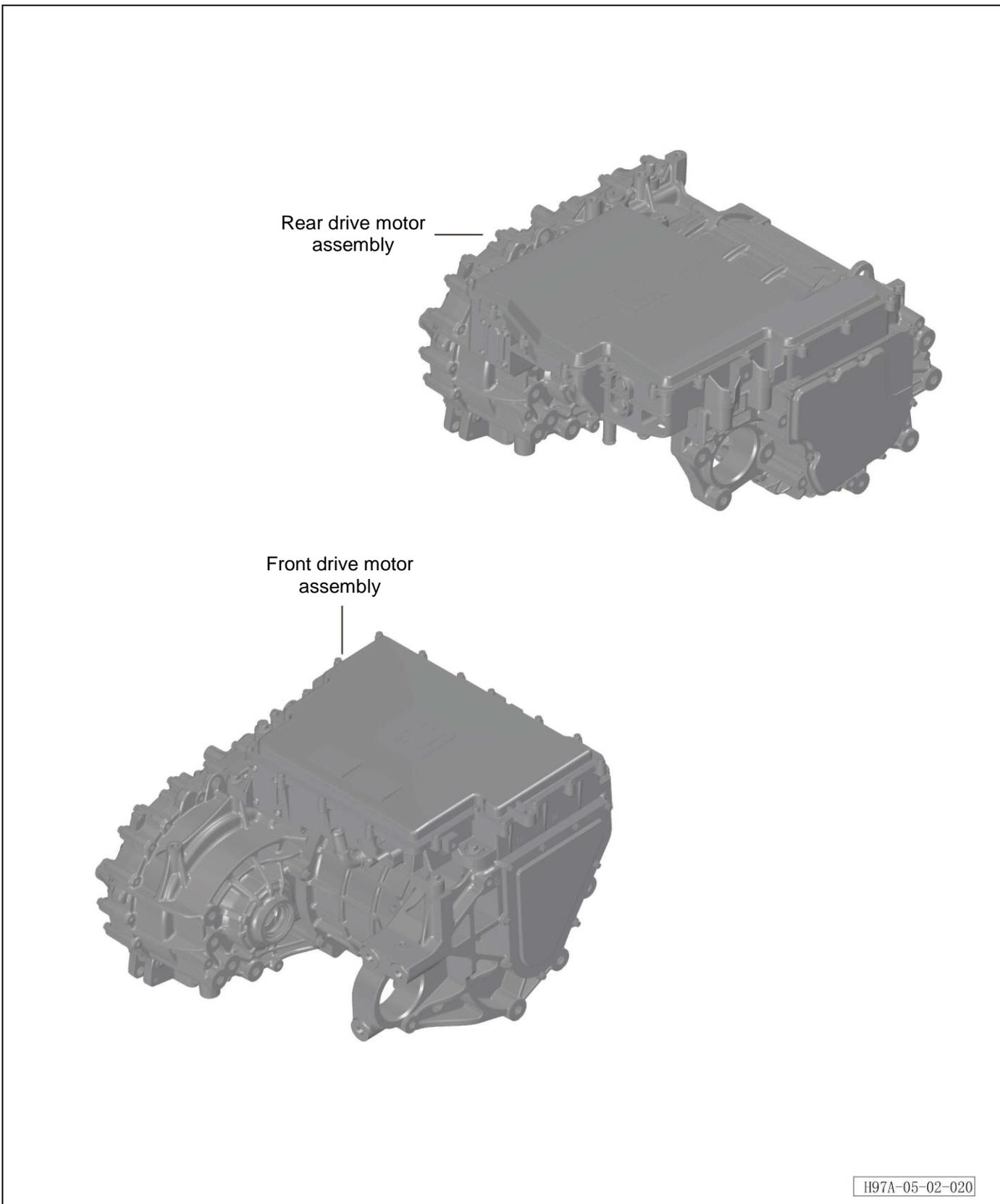

5.2.3 Front electric drive system

5.2.3.1 Removal and refitting of front drive motor assembly (REV)

Removal procedure

NOTE

- Take note of warnings and instructions for maintenance of the HV system. For details, refer to [5.5.1 Warnings and instructions for operations related to HV electronic control system](#).

- Before removing the front drive motor assembly, drain front drive motor coolant and brake fluid

CAUTION:

- For the lifting operation of the vehicle with air suspension, please refer to the precautions in the chapter and the disassembly & assembly and maintenance chapter of front/rear air springs.

- After adjusting the body to the standard height, touch the maintenance icon on the touch screen to adjust the system to the maintenance mode;

1. Turn off all electrical appliances and turn off the start switch.

2. Open the engine hood.

3. Remove the engine compartment trim panel.

4. Disconnect the battery negative terminal. Refer to [3.1.6.1 Maintenance and inspection battery](#)

5. Discharge front drive motor assembly lubricating oil (refer to [3.1.4.11 Change of front drive motor assembly lubricating oil](#)).

6. Remove wheel assembly.

7. Remove front subframe assembly (refer to [6.7.12.6 Removal and refitting of front subframe assembly \(REV - facelift\)](#))

8. Remove front drive motor.

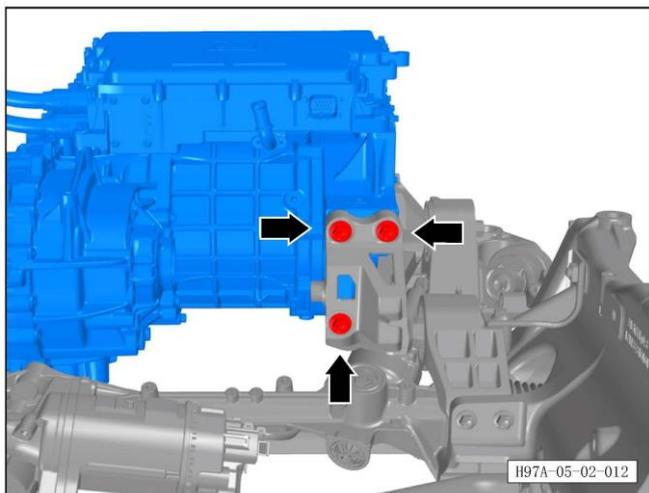

a. Unscrew 3 fixing bolts of front drive motor left front mounting.

Tightening torque of bolt: $60\pm 5\text{Nm}$.

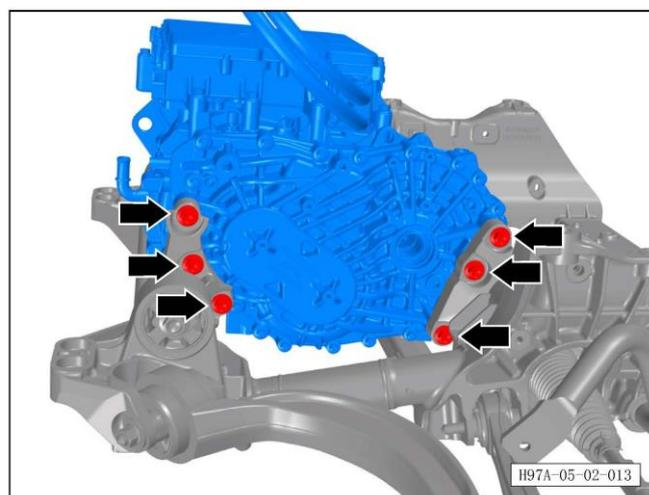

b. Unscrew 6 fixing bolts of front drive motor right front mounting.

Tightening torque of bolt: $60\pm 5\text{Nm}$.

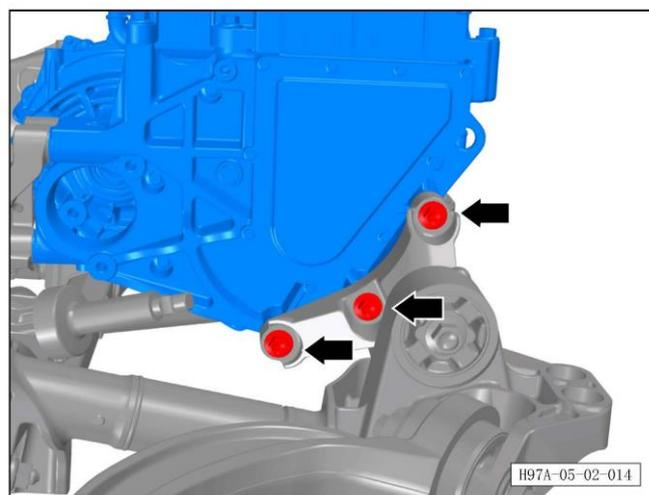

c. Unscrew 3 fixing bolts of front drive motor left rear mounting.

Tightening torque of bolt: $60\pm 5\text{Nm}$.

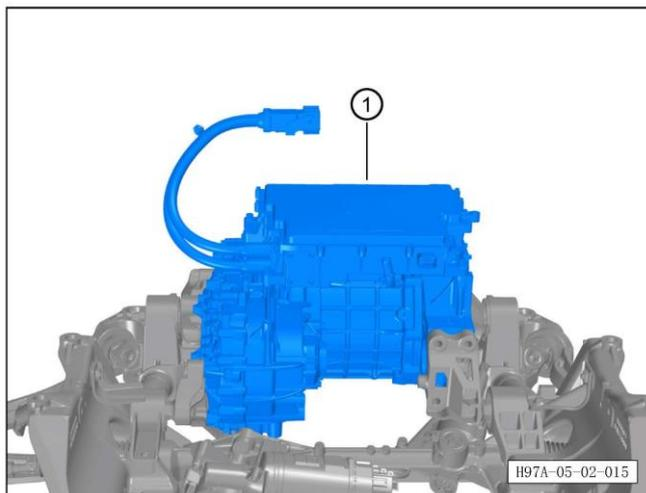

d. Remove front drive motor ①.

Refitting procedure

The refitting procedure is performed in reverse order.

CAUTION:

- After refitting chassis parts, change the brake fluid with new fluid, discharge the air and do not mix new and old brake fluid.
- Change drive motor reducer oil with new oil according to standard parameters of the drive motor.
- After the entire vehicle is refitted, carry out four-wheel alignment and road test of the vehicle to confirm that there is no deviation or abnormal noise.
- Coolant cannot be reused, mixed or replaced with that of different colors.
- Fill coolant to the required position and close the water reservoir end cover.
- Coolant recovery must be handled in accordance with relevant national regulations.
- Connect battery negative terminal.
- Before refitting, add brake fluid.

5.2.3.2 Removal and refitting of front drive motor assembly (EV)

Removal procedure

CAUTION:

- For the lifting operation of the vehicle with air suspension, please refer to the precautions in the chapter and the disassembly & assembly and maintenance chapter of front/rear air springs.

- After adjusting the body to the standard height, touch the maintenance icon on the touch screen to adjust the system to the maintenance mode.

1. Remove front subframe assembly (EV) (refer to [6.7.12.5 Removal and refitting of front subframe assembly \(EV - facelift\)](#))

2. Remove front drive motor assembly.

a. Unscrew 4 fixing bolts between front drive motor and right front motor mounting assembly.

Tightening torque of bolt: $60\pm 5\text{Nm}$.

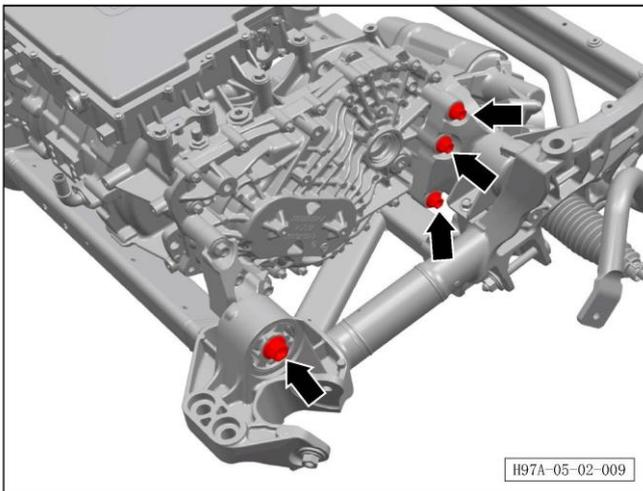

b. Unscrew 4 fixing bolts between front drive motor and left front motor mounting assembly.

Tightening torque of bolt: $60\pm 5\text{Nm}$.

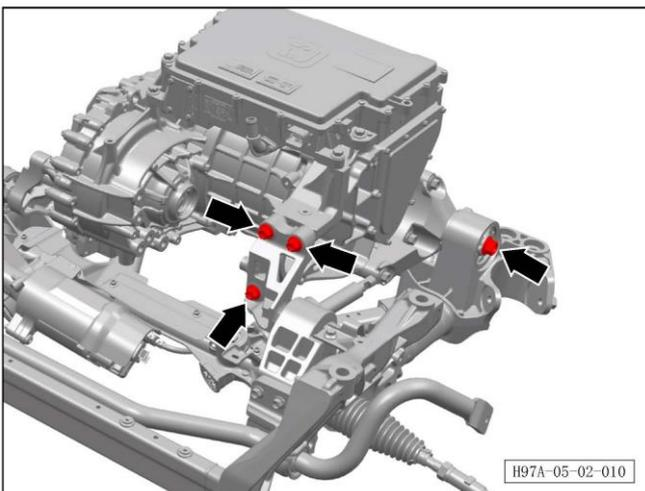

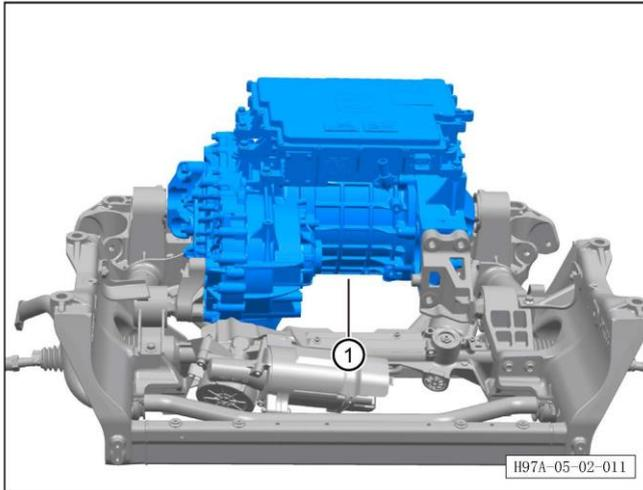

c. Remove front drive motor assembly ①.

Refitting procedure

The refitting procedure is performed in reverse order.

5.2.4 Rear electric drive system

5.2.4.1 Removal and refitting of rear drive motor assembly

Removal procedure

CAUTION:

- For the lifting operation of the vehicle with air suspension, please refer to the precautions in the chapter and the disassembly & assembly and maintenance chapter of front/rear air springs.
- After adjusting the body to the standard height, touch the maintenance icon on the touch screen to adjust the system to the maintenance mode;

NOTE

- Take note of warnings and instructions for maintenance of the HV system. For details, refer to [5.5.1 Warnings and instructions for operations related to HV electronic control system](#).

1. Turn off all electrical appliances and the start switch.
2. Disconnect the battery negative terminal. Refer to [3.1.6.1 Maintenance and inspection battery](#)
3. Remove the rear subframe assembly (refer to [6.7.13.2 Removal and refitting of rear subframe assembly](#))
4. Remove right rear drive shaft assembly (refer to [6.7.15.3 Removal and refitting of right rear drive shaft assembly](#))
5. Remove left rear drive shaft assembly (refer to [6.7.15.2 Removal and refitting of left rear drive shaft assembly](#))
6. Remove rear drive motor assembly.

- a. Unscrew 4 fixing bolts of the rear motor front mounting.

Tightening torque of bolt: $60 \pm 5 \text{ Nm}$.

CAUTION:

- c. Before unscrewing the fixing bolt of the rear motor mounting, support the rear drive system assembly with a top jacking device.

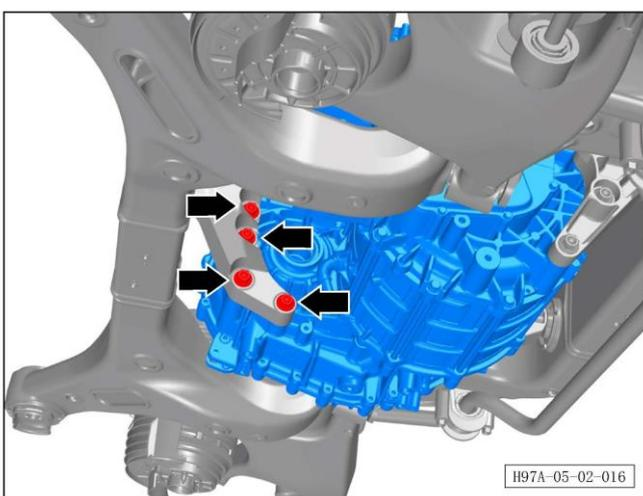

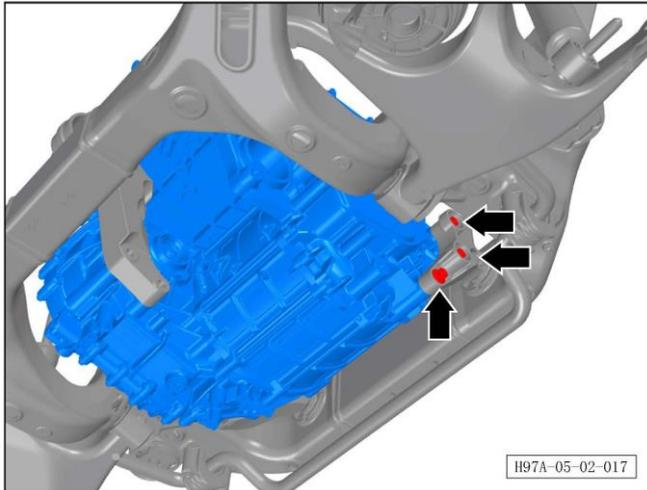

b. Unscrew 3 fixing bolts of the rear motor left mounting assembly.

Tightening torque of bolt: (60 ± 5) Nm.

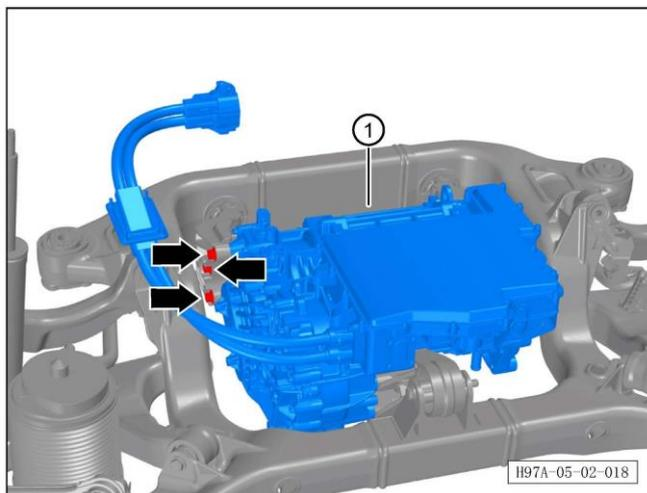

c. Unscrew 3 fixing bolts of the rear motor right mounting assembly, and remove the rear drive motor assembly ①.

Tightening torque of bolt: (60 ± 5) Nm.

CAUTION:

- If the rear motor is wrapped, you must separate the package of the rear motor.

Refitting procedure

The refitting procedure is performed in reverse order.

CAUTION:

- Do not forget to refit the drive motor water inlet and outlet pipes during refitting.
- After refitting, supplement or change coolant and change drive motor reducer gear oil according to the actual situation.
- Coolant cannot be reused or mixed. Check whether the coolant level is between the MAX (highest) and MIN (lowest) marks.
- Reducer gear oil cannot be reused or mixed.
- After refitting, carry out four-wheel alignment and road test to ensure that there are no abnormal noises in chassis parts or deviations during driving.

5.3 Vehicle control and management system

5.3.1 Introduction to structure and principle

- VCU can be woken up when the vehicle is turned to KL15 ON position (the start switch is applied with low voltage) or through CAN network management message. When VCU wakes up, it can monitor the function requirements of the vehicle and activate basic functions required for VCU.
- When the user set the vehicle to KL15 OFF, VCU will enter sleep state and stop working in case there are no functional requirements.

5.3.2 Position diagram of parts



5.3.3 Exploded view

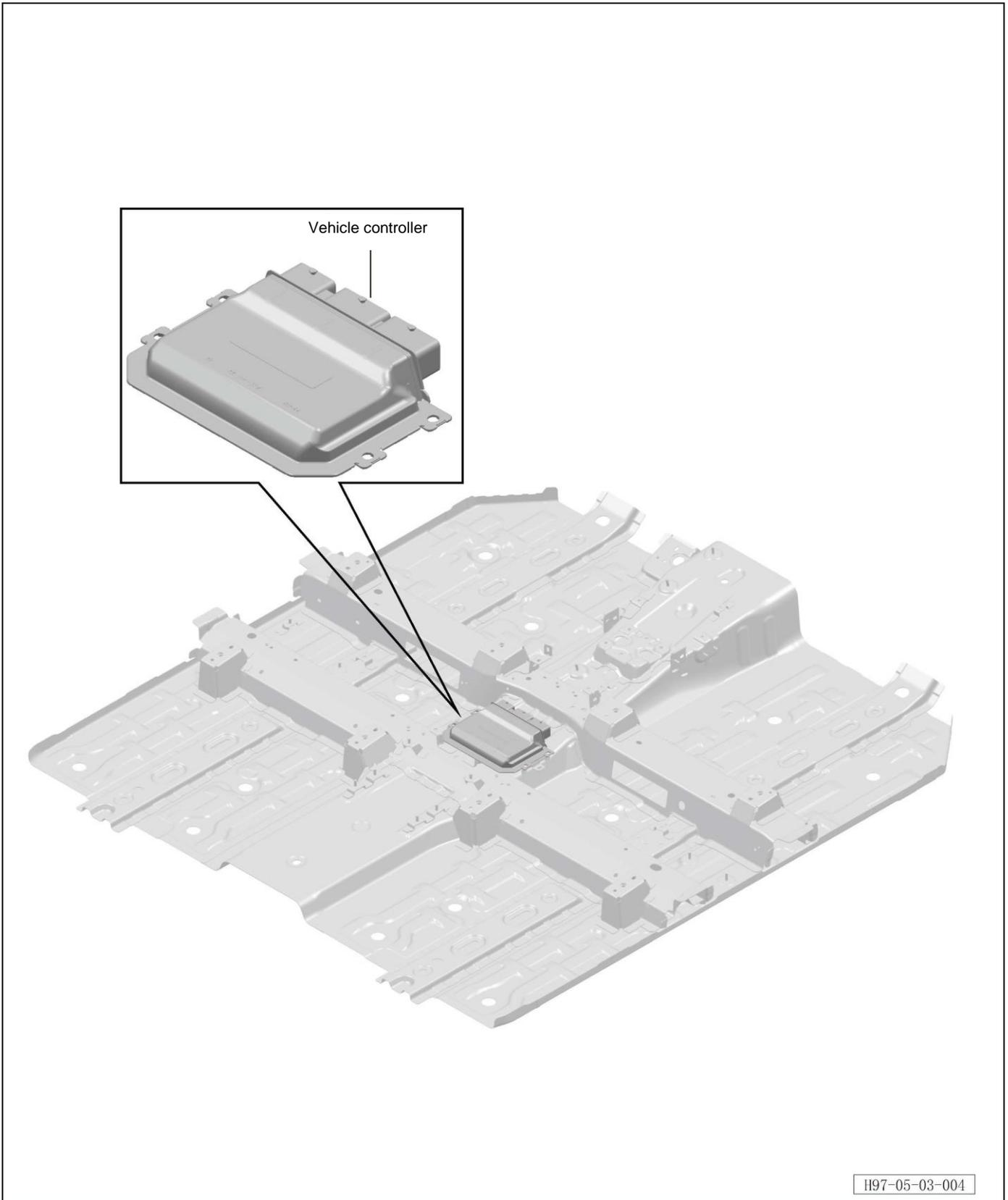

5.3.4 VCU

5.3.4.1 Removal and refitting of VCU assembly

Removal procedure

1. Turn off all electrical appliances and the start switch.
2. Disconnect the battery negative terminal. Refer to [3.1.6.1 Maintenance and inspection battery](#)
3. Remove console assembly (refer to [8.3.4.22 Removal and refitting of console assembly](#))
4. Remove VCU assembly.

a. Disconnect 3 connectors of cab harness.

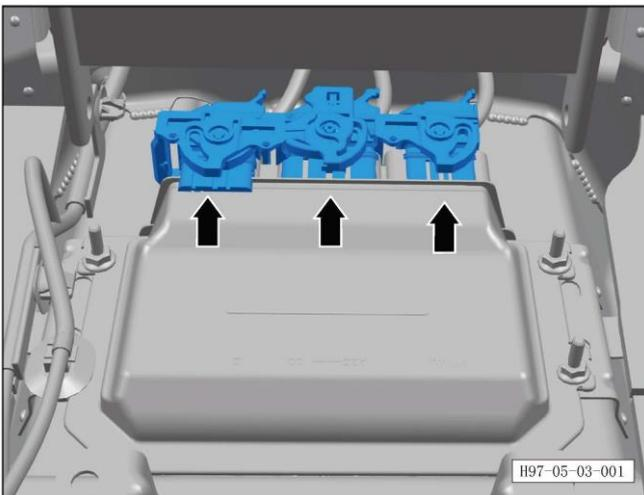

b. Unscrew 4 fixing nuts of VCU.
Tightening torque of nut: $5\pm 0.8\text{Nm}$.

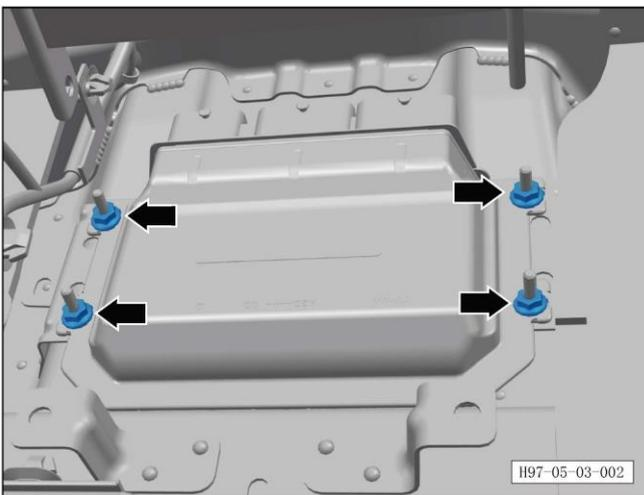

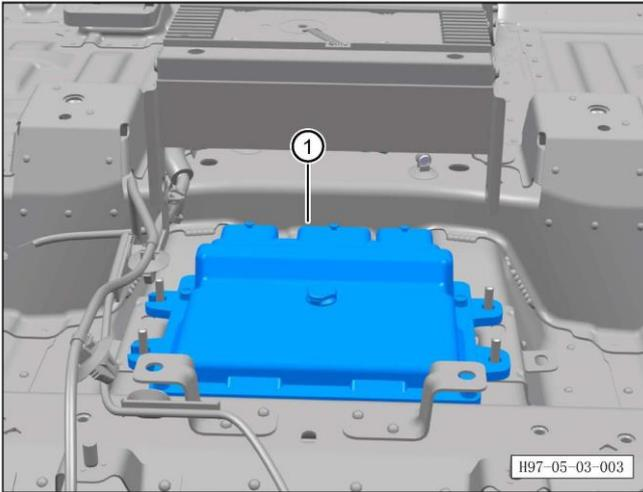

c. Remove VCU assembly ①.

Refitting procedure

The refitting procedure is performed in reverse order.

5.4 HV assembly system

5.4.1 Precautions

WARNING:

1. The vehicle is equipped with a hybrid power system operating at 350 V.
2. Operate the system correctly according to the instructions stipulated in this manual. Otherwise, you may face a risk of serious injury or death caused by electric shock.
3. Do not touch HV cables, and if you need to touch them, follow the instructions below:
 - a. Wear insulating gloves and safety goggles.
 - b. Measure the voltage between the cable and body ground with an electronic tester.
 - c. Insulate the cable with insulating tape.
4. If any HV components and cables are possibly damaged, disconnect the negative terminal of the battery and wait 3 minutes before working again.
4. When conducting maintenance and removal of the high voltage battery, the following operations are strictly prohibited:
 - a. Measure the voltage at HV connector of the high voltage battery that is suspected to be damaged (careless operation will cause a short circuit, resulting in casualties).
 - b. Store the high voltage battery that is suspected to be damaged in the open air (such battery should be wrapped, insulated and free of damage).
 - c. Reload the suspected damaged high voltage battery on the vehicle.
5. The following items must be noticed when maintaining the HV system, otherwise personal injuries or deaths may occur:
 - a. De-energize HV systems only by professionals (HV electricians).
 - b. HV electricians shall ensure that the power supply is disconnected and wait 10 minutes before working again.
 - c. HV electricians shall put away the smart remote key.
 - d. HV electrician shall attach a sign as appropriate to indicate whether the vehicle power supply is disconnected or not. All related operations (e.g., Maintenance, or repair of the electrical system) of vehicle HV system can only be performed by professionals that have been trained in electrical knowledge.
 - e. If you have any question, please consult relevant HV electricians. Before performing any operations on HV system and any maintenance on the body, HV electricians must disconnect the power supply.
 - f. Ask only professional electricians to carry out maintenance on the HV system if it cannot be de-energized.
 - g. When operating HV systems, wear HV protective equipment such as HV insulating gloves, insulating shoes, and special HV insulating tools. Precautions for inspection and repair of HV circuits:
 - h. Technicians must be specially trained before repairing and inspecting HV systems.
 - i. Stick a sign "WARNING: HIGH VOLTAGE! DO NOT TOUCH!" to inform other technicians that the HV system is being inspected or repaired.
 - j. All HV harnesses and connectors are orange. High voltage batteries and other HV components are attached with a "HIGH VOLTAGE" warning label. Do not touch these harnesses or parts indiscriminately.
 - k. Do not attempt to repair faulty harnesses or connectors of a HV circuit. Replace damaged or faulty HV cables or connectors directly.
 - l. Persons wearing artificial cardiopulmonary aids shall not operate on vehicles equipped with HV systems. The artificial cardiopulmonary aids include built-in pain pump, implantable defibrillator, cardiac pacemaker, insulin pump and hearing aids.
 - m. Wear personal protective equipment (including face protection device) when carrying out maintenance and removal of faulty high voltage batteries before ensuring normal insulation and removing the electrical series connection of the modules.

5.4.2 Position diagram of parts

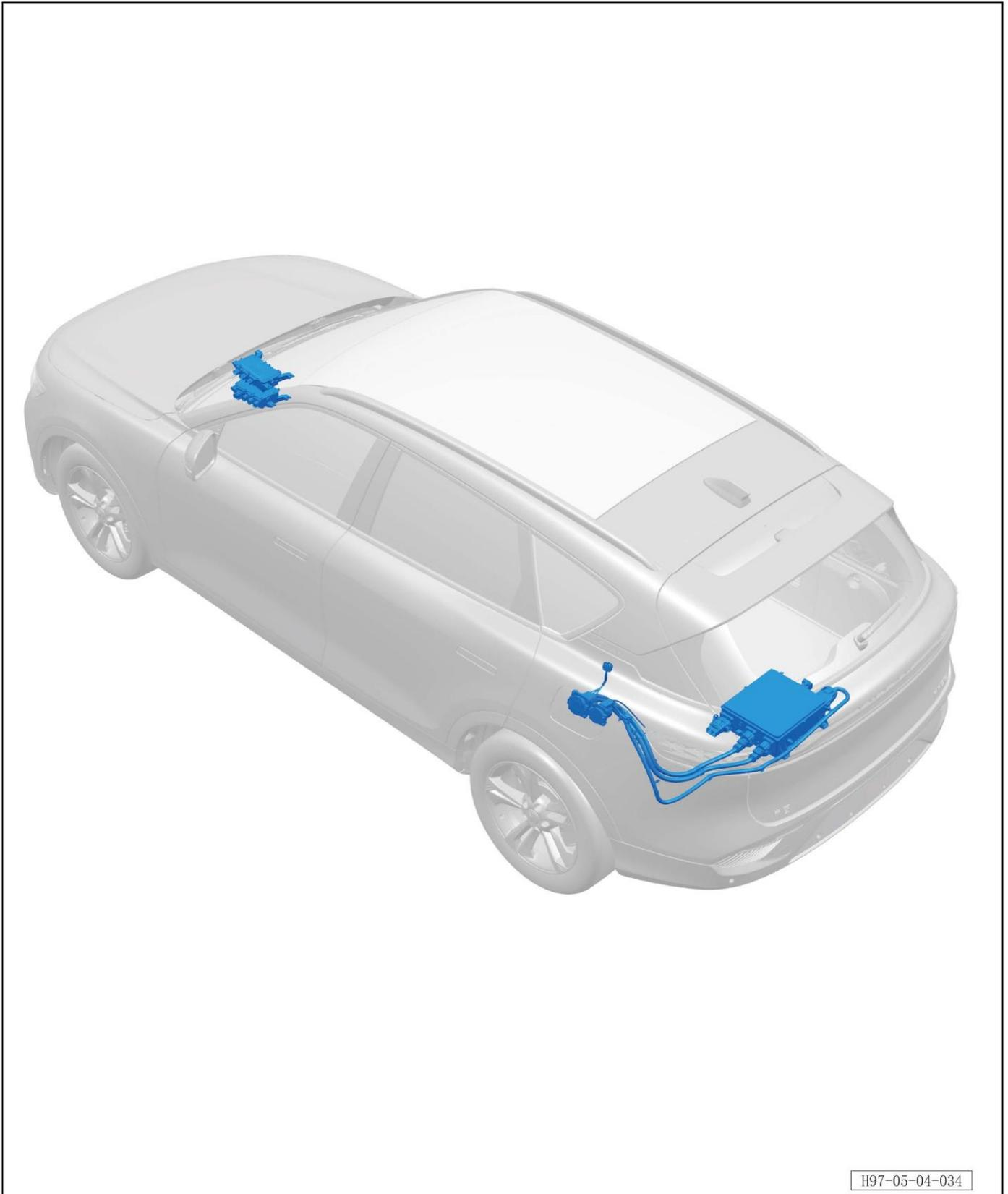

5.4.3 Exploded view

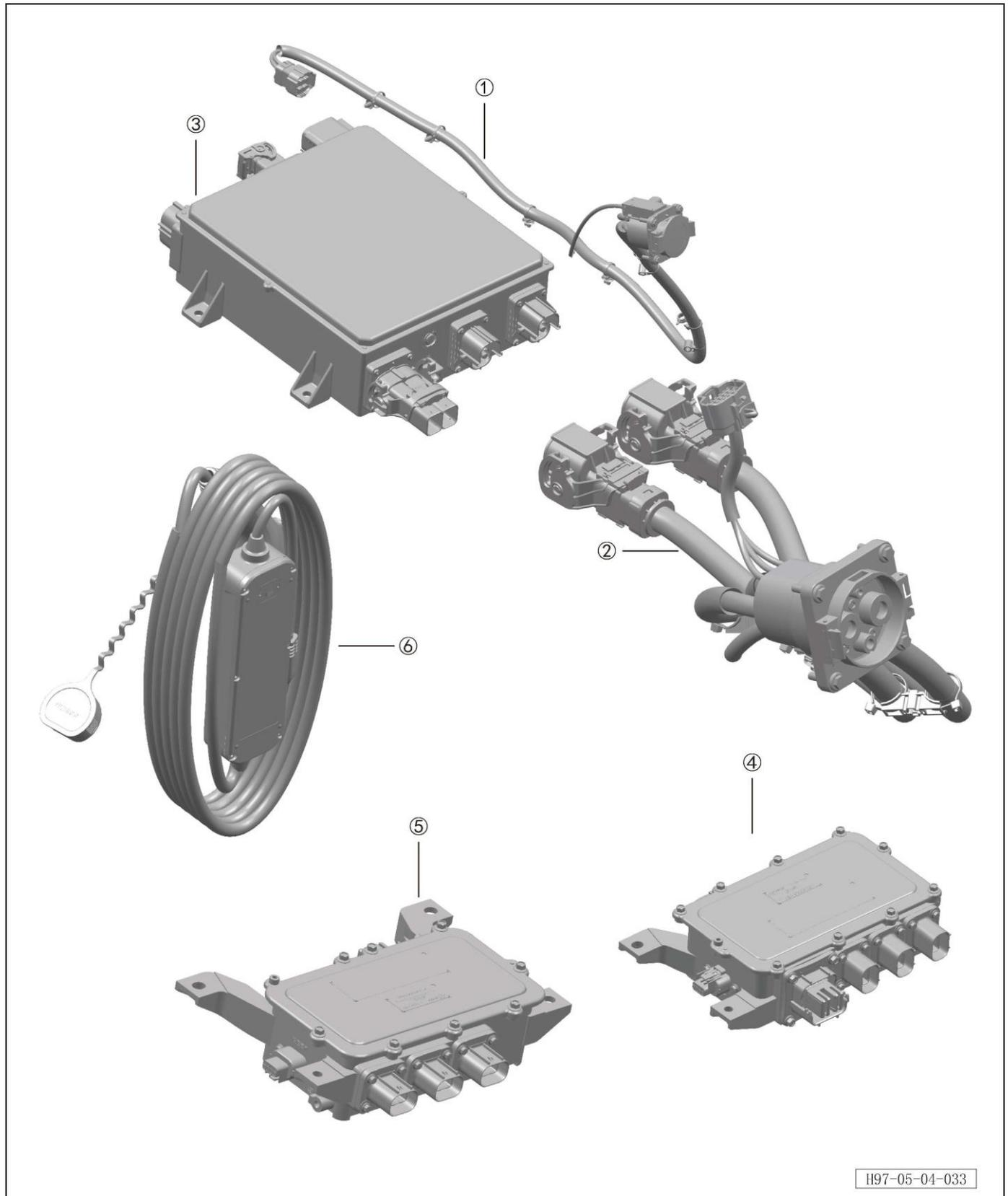

S/N	Part name	Loading quantity	Remarks
1	Slow charging socket assembly	1	
2	Fast charging socket assembly	1	
3	OBC assembly	1	
4	Engine compartment PDU assembly	1	REV
5	Engine compartment PDU assembly	1	EV
6	Mode 2 charging gun	1	

5.4.4 PDU

5.4.4.1 Removal and refitting of engine compartment PDU assembly (REV)

Removal procedure

NOTE

- Take note of warnings and instructions for maintenance of the HV system. For details, refer to [5.5.1 Warnings and instructions for operations related to HV electronic control system](#).

1. Turn off all electrical appliances and the start switch.
2. Disconnect the battery negative terminal. Refer to [3.1.6.1 Maintenance and inspection battery](#)
3. Lift the vehicle.
4. Remove front drive motor assembly (refer to [5.2.3.1 Removal and refitting of front drive motor assembly \(REV\)](#)).
5. Remove engine compartment PDU assembly.

a. Disconnect front motor HV harness connector A and GCU HV harness connector B.

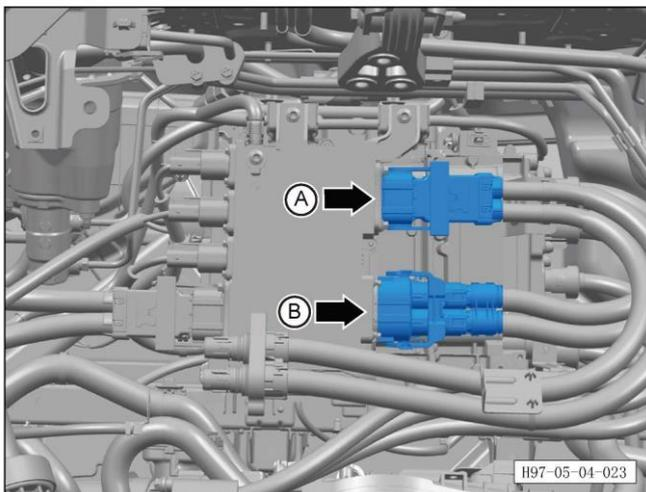

b. Disconnect A/C PTC HV harness connector A and compressor HV harness connector B.

Disconnect battery PTC HV harness connector C and battery pack front HV harness connector D.

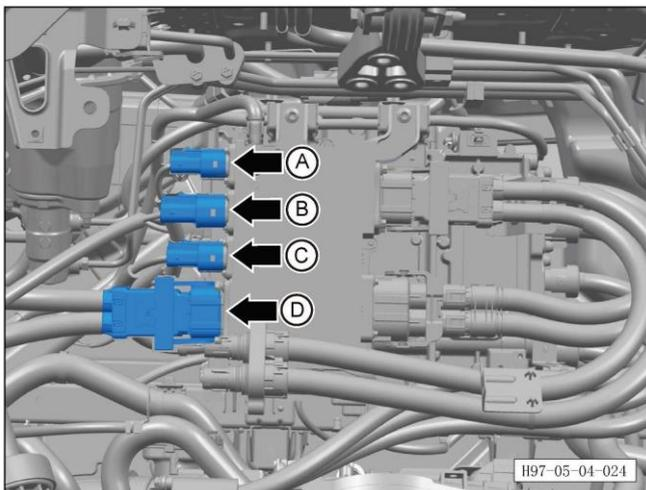

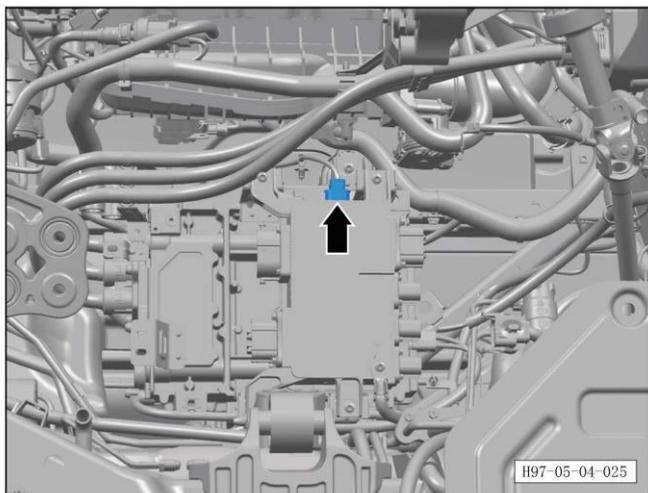

c. Disconnect engine harness connector.

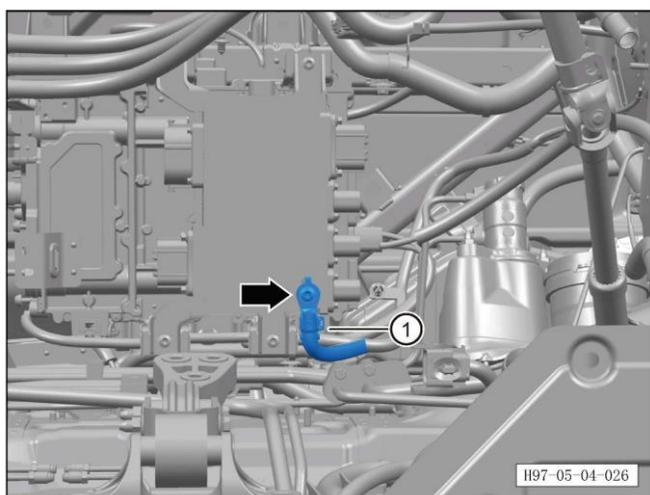

d. Unscrew the fixing bolt of engine compartment PDU ground wire, and remove engine compartment PDU ground wire ①.

Tightening torque of bolt: $8\pm 1\text{Nm}$.

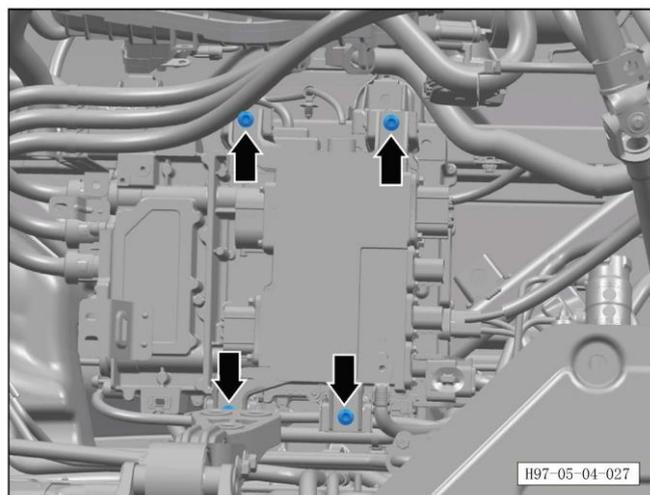

e. Unscrew 4 fixing bolts of engine compartment PDU.
Tightening torque of bolt: $20\pm 3\text{Nm}$.

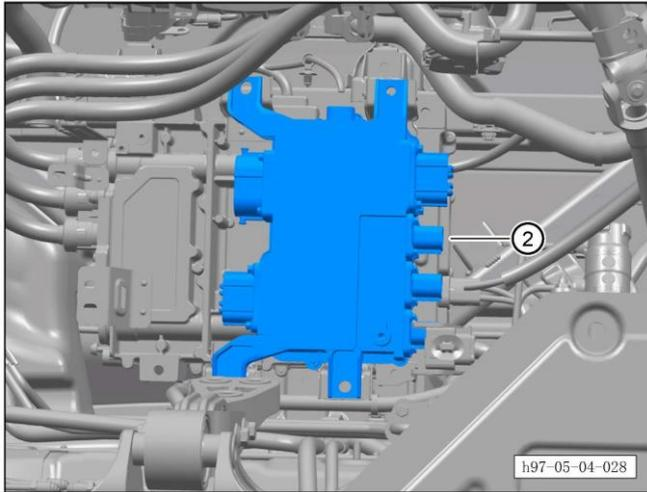

f. Remove engine compartment PDU ②.

Refitting procedure

The refitting procedure is performed in reverse order.

5.4.4.2 Removal and refitting of engine compartment PDU assembly (EV)

Removal procedure

NOTE

- Take note of warnings and instructions for maintenance of the HV system. For details, refer to [5.5.1 Warnings and instructions for operations related to HV electronic control system](#).

1. Turn off all electrical appliances and the start switch.

2. Disconnect the battery negative terminal. Refer to [3.1.6.1 Maintenance and inspection battery](#)

3. Removing the trunk carpet assembly (refer to [8.5.8.1 Removal and refitting of trunk carpet assembly](#))

4. Remove slow charging socket assembly.

a. Disconnect A/C PTC HV harness connector A and engine compartment battery heating PTC - compressor HV harness connector B.

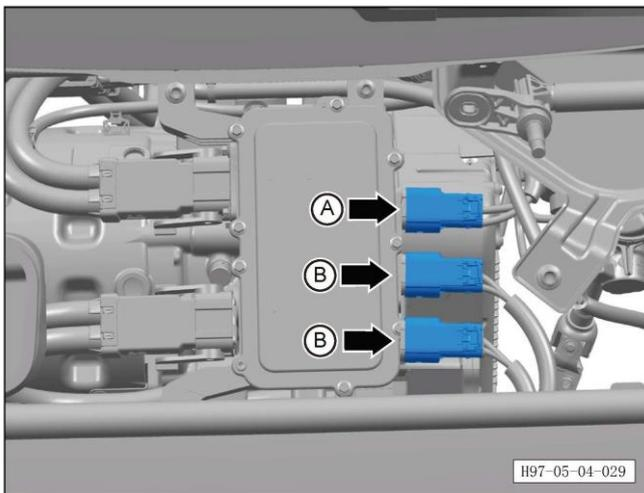

b. Disconnect battery pack front HV harness connector A and front motor HV harness connector B.

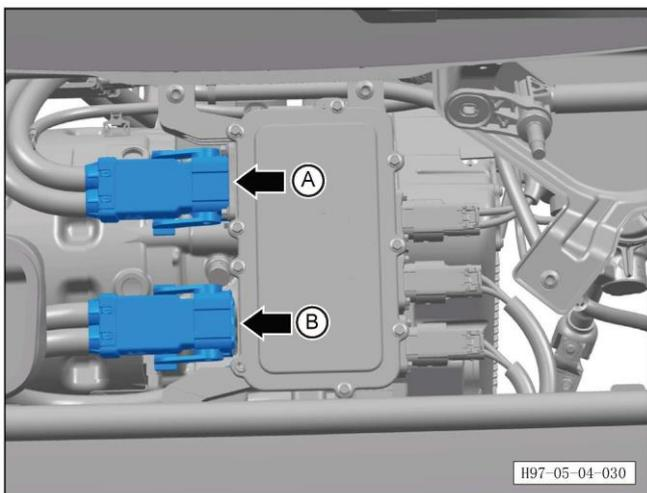

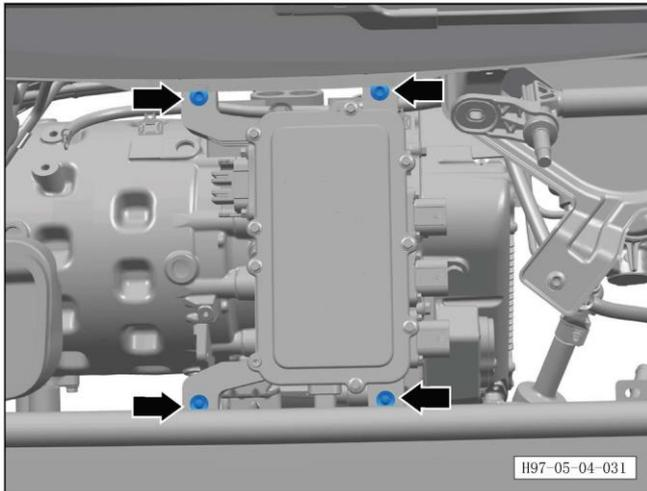

c. Unscrew 4 fixing bolts of engine compartment PDU.
Tightening torque of bolt: $20\pm 3\text{Nm}$.

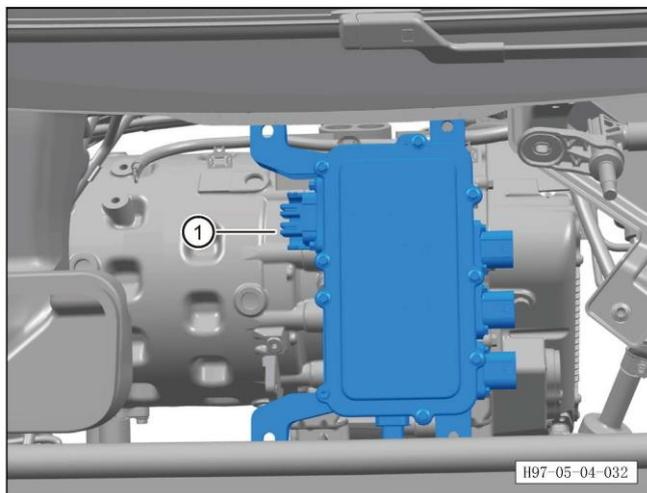

d. Remove engine compartment PDU ①.

Refitting procedure

The refitting procedure is performed in reverse order.

5.4.5 Charging socket

5.4.5.1 Removal and refitting of slow charging socket

Removal procedure

NOTE

- Take note of warnings and instructions for maintenance of the HV system. For details, refer to [5.5.1 Warnings and instructions for operations related to HV electronic control system](#).

1. Turn off all electrical appliances and the start switch.

2. Disconnect the battery negative terminal. Refer to [3.1.6.1 Maintenance and inspection battery](#)

3. Remove trunk carpet assembly (refer to [8.5.8.1 Removal and refitting of trunk carpet assembly](#))

4. Remove slow charging socket.

a. Disconnect OBC connector A and disengage 2 harness clips B of slow charging socket.

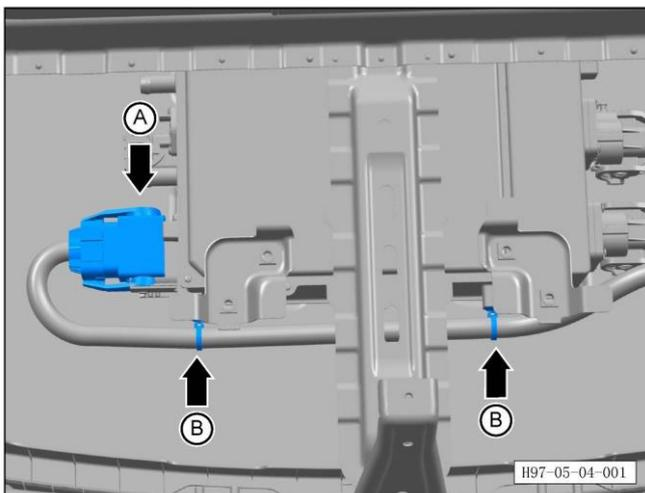

b. Disconnect 2 harness clips of slow charging socket.

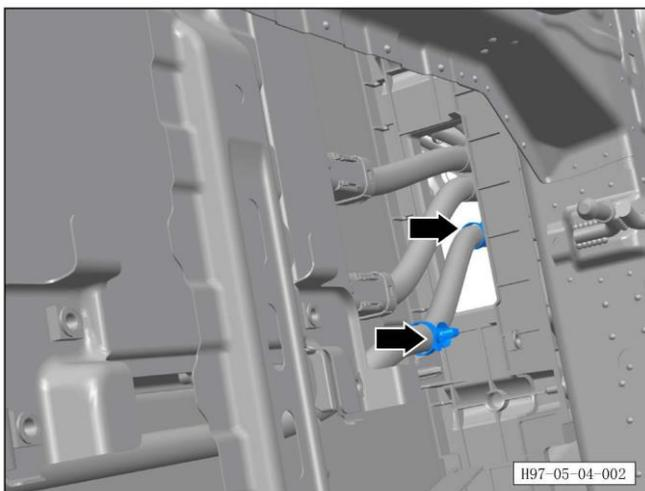

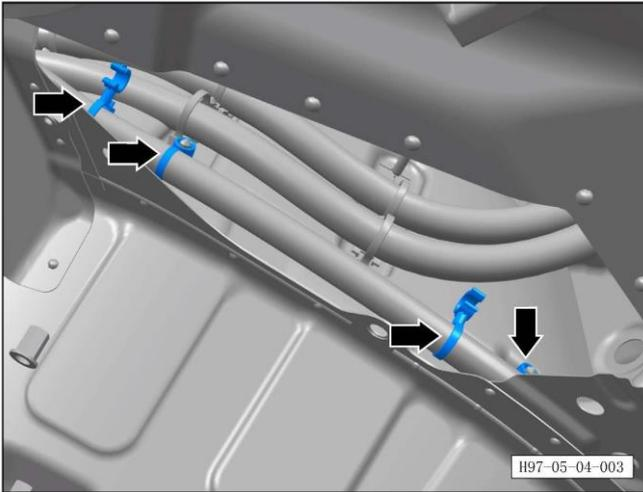

c. Disconnect 4 harness clips of slow charging socket.

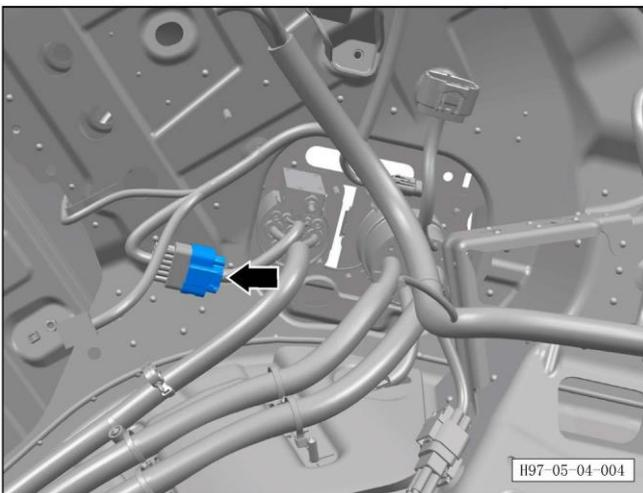

d. Disconnect slow charging socket connector.

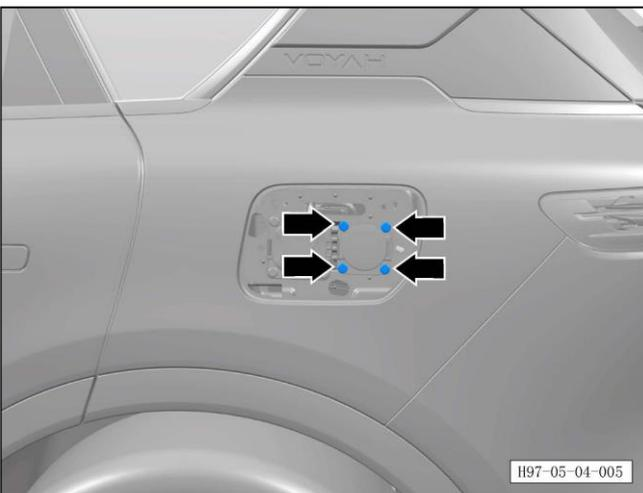

e. Unscrew 4 fixing bolts of slow charging socket.
Tightening torque of bolt: $20\pm 3\text{Nm}$.

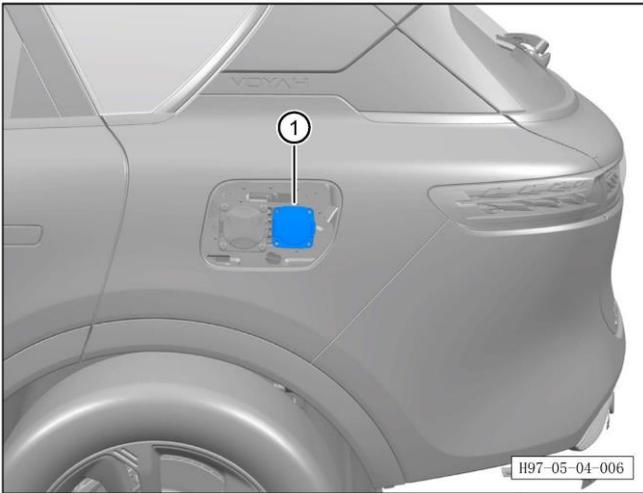

f. Remove slow charging socket ①.

Refitting procedure

The refitting procedure is performed in reverse order.

5.4.5.2 Removal and refitting of fast charging socket assembly

Removal procedure

NOTE

- Take note of warnings and instructions for maintenance of the HV system. For details, refer to [5.5.1 Warnings and instructions for operations related to HV electronic control system](#).

1. Turn off all electrical appliances and the start switch.

2. Disconnect the battery negative terminal. Refer to [3.1.6.1 Maintenance and inspection battery](#)

3. Removing the trunk carpet assembly (refer to [8.5.8.1 Removal and refitting of trunk carpet assembly](#))

4. Remove slow charging socket.

a. Disconnect 2 connectors of OBC and disengage 2 harness clips B of fast charging socket.

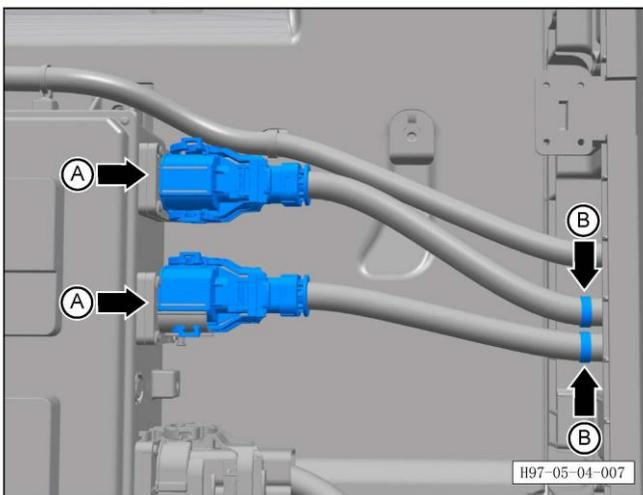

b. Disengage 3 harness clips of fast charging socket.

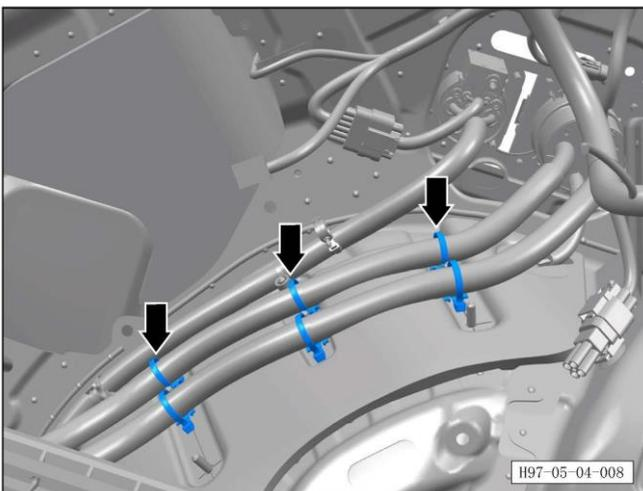

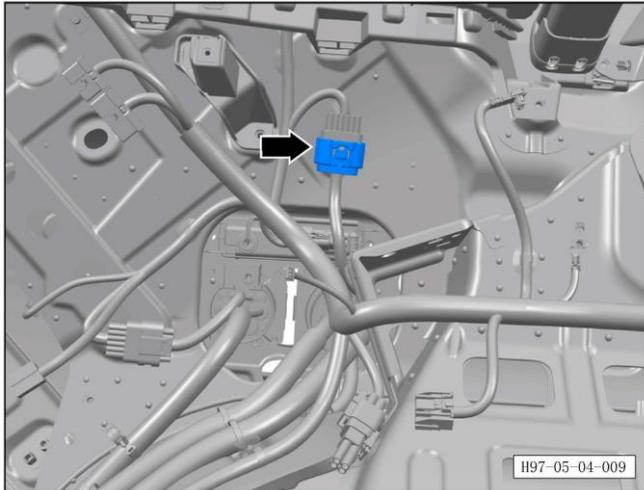

c. Disconnect fast charging socket connector.

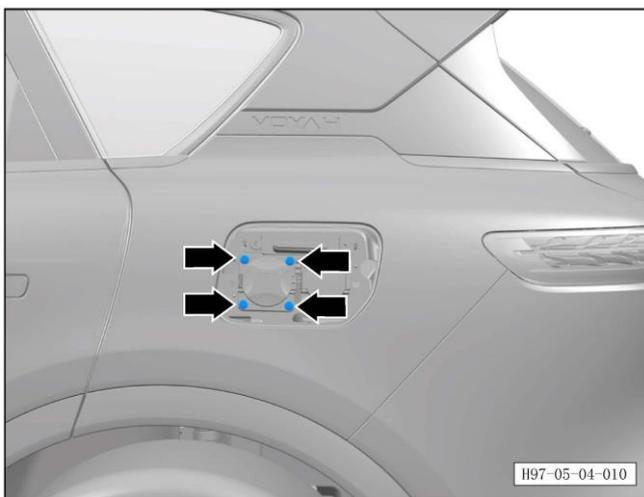

d. Unscrew 4 fixing bolts of fast charging socket.
Tightening torque of bolt: $20\pm 3\text{Nm}$.

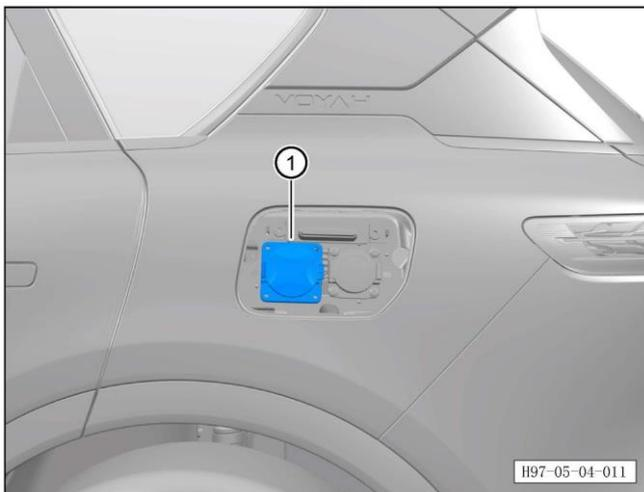

e. Remove fast charging socket ①.

Refitting procedure

The refitting procedure is performed in reverse order.

5.4.6 OBC

5.4.6.1 Removal and refitting of OBC assembly

Removal procedure

NOTE

- Take note of warnings and instructions for maintenance of the HV system. For details, refer to [5.5.1 Warnings and instructions for operations related to HV electronic control system](#).

1. Turn off all electrical appliances and the start switch.

2. Disconnect the battery negative terminal. Refer to [3.1.6.1 Maintenance and inspection battery](#)

3. Discharge drive motor and high voltage battery coolant (refer to [3.1.4.7 Change of drive motor and high voltage battery coolant \(REV\)](#))

4. Removing the trunk carpet assembly (refer to [8.5.8.1 Removal and refitting of trunk carpet assembly](#))

5. Remove OBC assembly.

a. Disconnect rear motor HV harness assembly connector A, auxiliary body harness connector B, slow charging socket assembly connector C, battery pack rear HV harness assembly connector D, and fast charging socket assembly connector E.

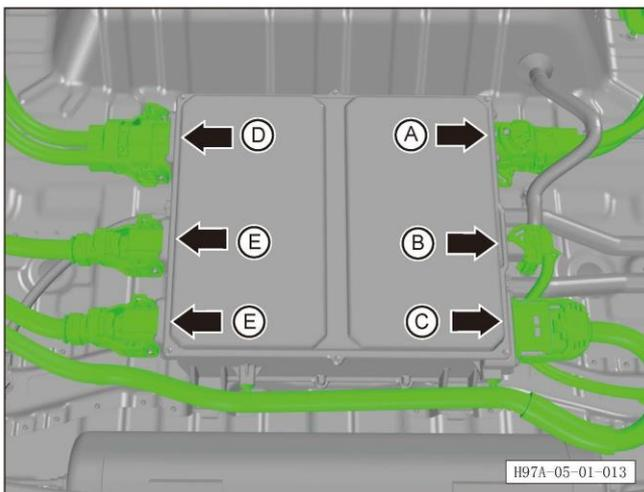

b. Loosen 2 clamps D of OBC water pipe assembly, and disengage OBC water pipe assembly.

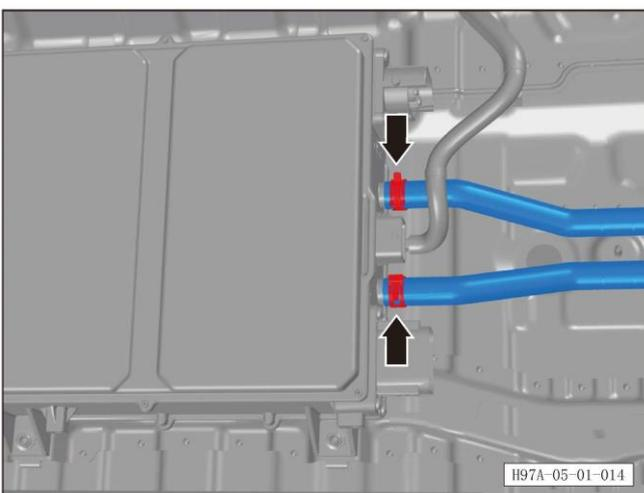

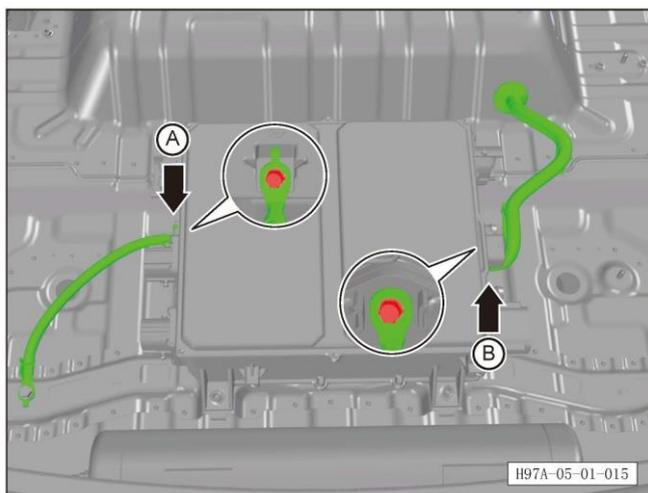

c. Unscrew the fixing bolt A of OBC ground wire, disconnect OBC ground wire, unscrew the fixing bolt B of the left engine compartment harness, and disconnect left engine compartment harness.

Tightening torque of bolt: $14\pm 2\text{Nm}$.

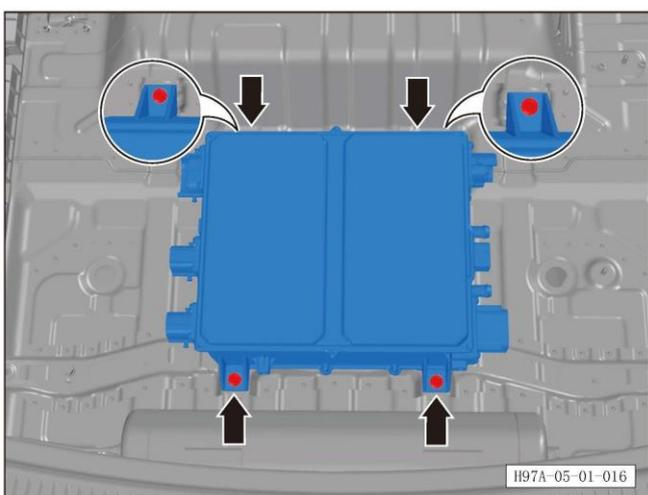

d. Unscrew 4 fixing bolts of OBC assembly and remove OBC assembly.

Tightening torque of bolt: $20\pm 3\text{Nm}$.

Refitting procedure

The refitting procedure is performed in reverse order.

CAUTION:

- Coolant cannot be reused, mixed or replaced with that of different colors.
- Fill coolant to the required position and close the water reservoir end cover.
- Coolant recovery must be handled in accordance with relevant national regulations.
- Connect battery negative terminal.

5.5 HV harness system

5.5.1 Precautions

WARNING:

1. The vehicle is equipped with a hybrid power system operating at 350 V.
2. Operate the system correctly according to the instructions stipulated in this manual. Otherwise, you may face a risk of serious injury or death caused by electric shock.
3. Do not touch HV cables, and if you need to touch them, follow the instructions below:
 - a. Wear insulating gloves and safety goggles.
 - b. Measure the voltage between the cable and body ground with an electronic tester.
 - c. Insulate the cable with insulating tape.
4. If any HV components and cables are possibly damaged, disconnect the negative terminal of the battery and wait 3 minutes before working again.
4. When conducting maintenance and removal of the high voltage battery, the following operations are strictly prohibited:
 - a. Measure the voltage at HV connector of the high voltage battery that is suspected to be damaged (careless operation will cause a short circuit, resulting in casualties).
 - b. Store the high voltage battery that is suspected to be damaged in the open air (such battery should be wrapped, insulated and free of damage).
 - c. Reload the suspected damaged high voltage battery on the vehicle.
5. The following items must be noticed when maintaining the HV system, otherwise personal injuries or deaths may occur:
 - a. De-energize HV systems only by professionals (HV electricians).
 - b. HV electricians shall ensure that the power supply is disconnected and wait 10 minutes before working again.
 - c. HV electricians shall put away the smart remote key.
 - d. HV electrician shall attach a sign as appropriate to indicate whether the vehicle power supply is disconnected or not. All related operations (e.g., Maintenance, or repair of the electrical system) of vehicle HV system can only be performed by professionals that have been trained in electrical knowledge.
 - e. If you have any question, please consult relevant HV electricians. Before performing any operations on HV system and any maintenance on the body, HV electricians must disconnect the power supply.
 - f. Ask only professional electricians to carry out maintenance on the HV system if it cannot be de-energized.
 - g. When operating HV systems, wear HV protective equipment such as HV insulating gloves, insulating shoes, and special HV insulating tools. Precautions for inspection and repair of HV circuits:
 - h. Technicians must be specially trained before repairing and inspecting HV systems.
 - i. Stick a sign "WARNING: HIGH VOLTAGE! DO NOT TOUCH!" to inform other technicians that the HV system is being inspected or repaired.
 - j. All HV harnesses and connectors are orange. High voltage batteries and other HV components are attached with a "HIGH VOLTAGE" warning label. Do not touch these harnesses or parts indiscriminately.
 - k. Do not attempt to repair faulty harnesses or connectors of a HV circuit. Replace damaged or faulty HV cables or connectors directly.
 - l. Persons wearing artificial cardiopulmonary aids shall not operate on vehicles equipped with HV systems. The artificial cardiopulmonary aids include built-in pain pump, implantable defibrillator, cardiac pacemaker, insulin pump and hearing aids.
 - m. Wear personal protective equipment (including face protection device) when carrying out maintenance and removal of faulty high voltage batteries before ensuring normal insulation and removing the electrical series connection of the modules.

6. Operation of HV lines:

- a. Take all safety measures, for example, wearing insulating gloves, before inspecting or maintaining HV systems.
- b. Do not rest your body or tools against HV lines and their components. It is forbidden to operate in the vicinity of HV components and lines by means of cutting, shaping and sharp tools.
- c. It is forbidden to use power sources in the vicinity of HV components and lines to carry out welding, brazing, thermal bonding, and hot-air operations.
- d. Wear HV protective equipment including: HV insulating gloves, insulating shoes, special tools, HV insulating wrench, socket, safety gauge, shaker (for testing insulation resistance), etc.
- e. Do not severely twist or bend HV lines. In case of any abnormality or any question, you must consult a HV electrician or a professional electrician.
- f. After power-off, wait 10 minutes before working again.

5.5.2 Layout of parts (REV)

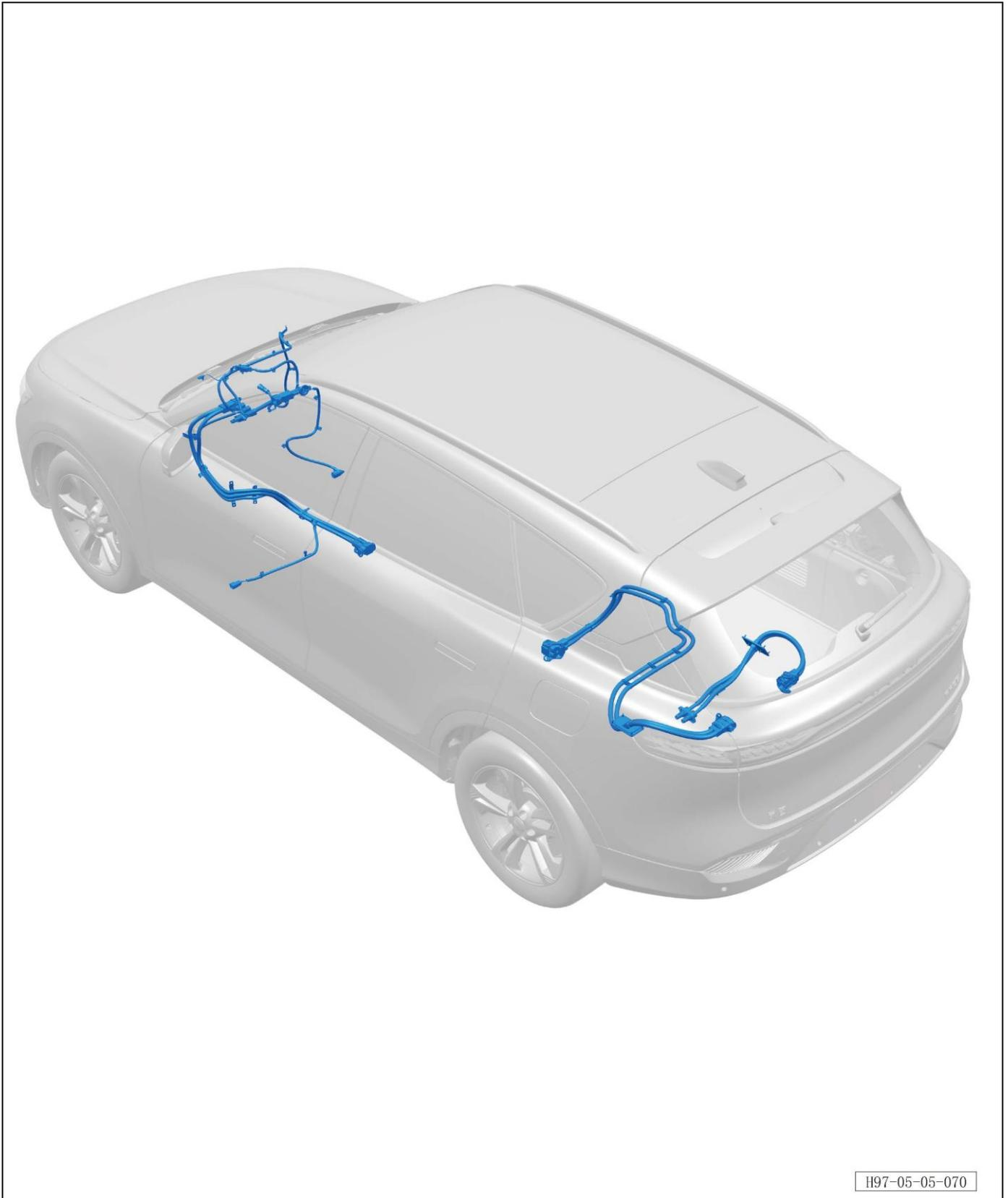

5.5.3 Layout of parts (EV)

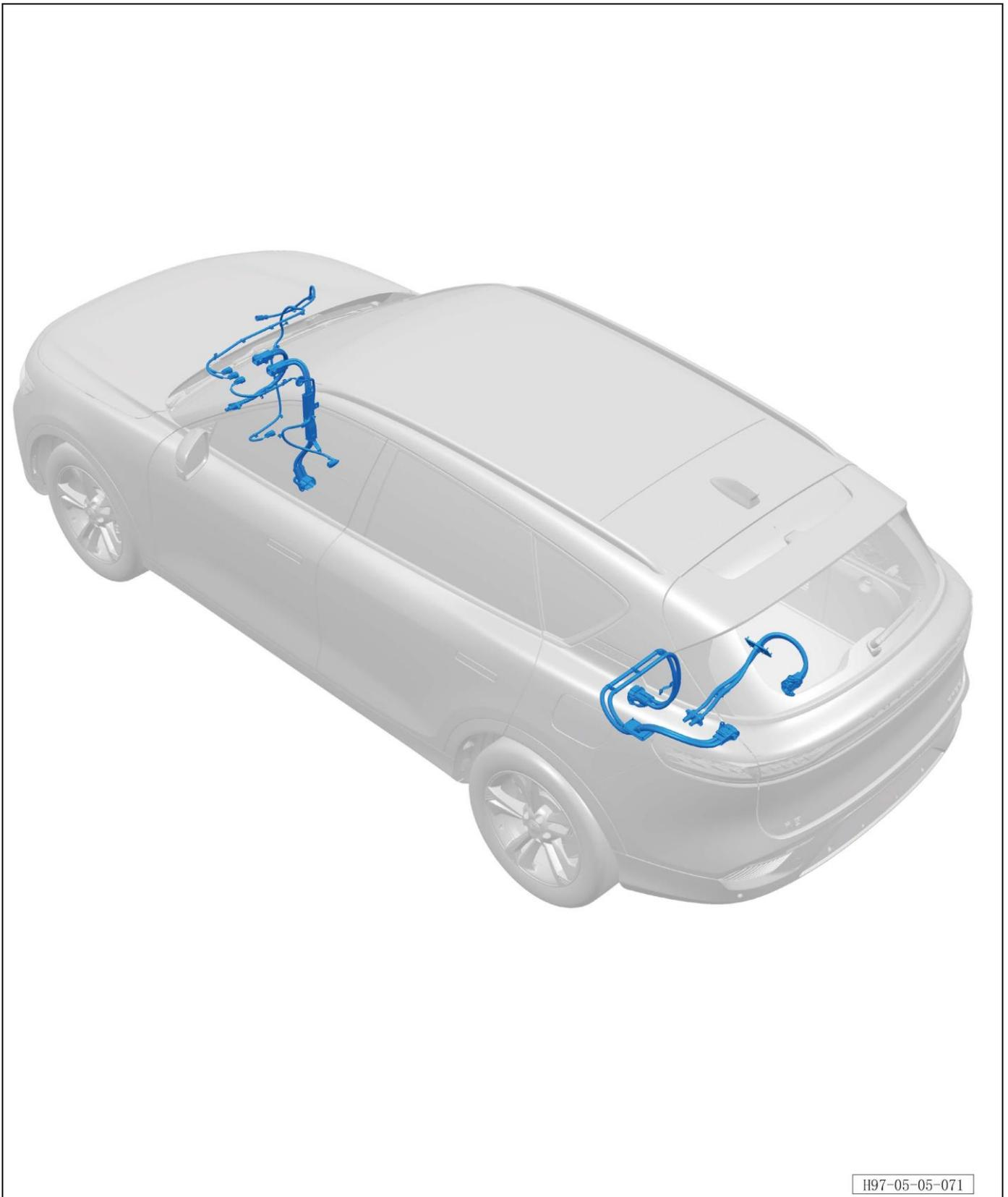

H97-05-05-071

5.5.4 Exploded view of structure (REV)

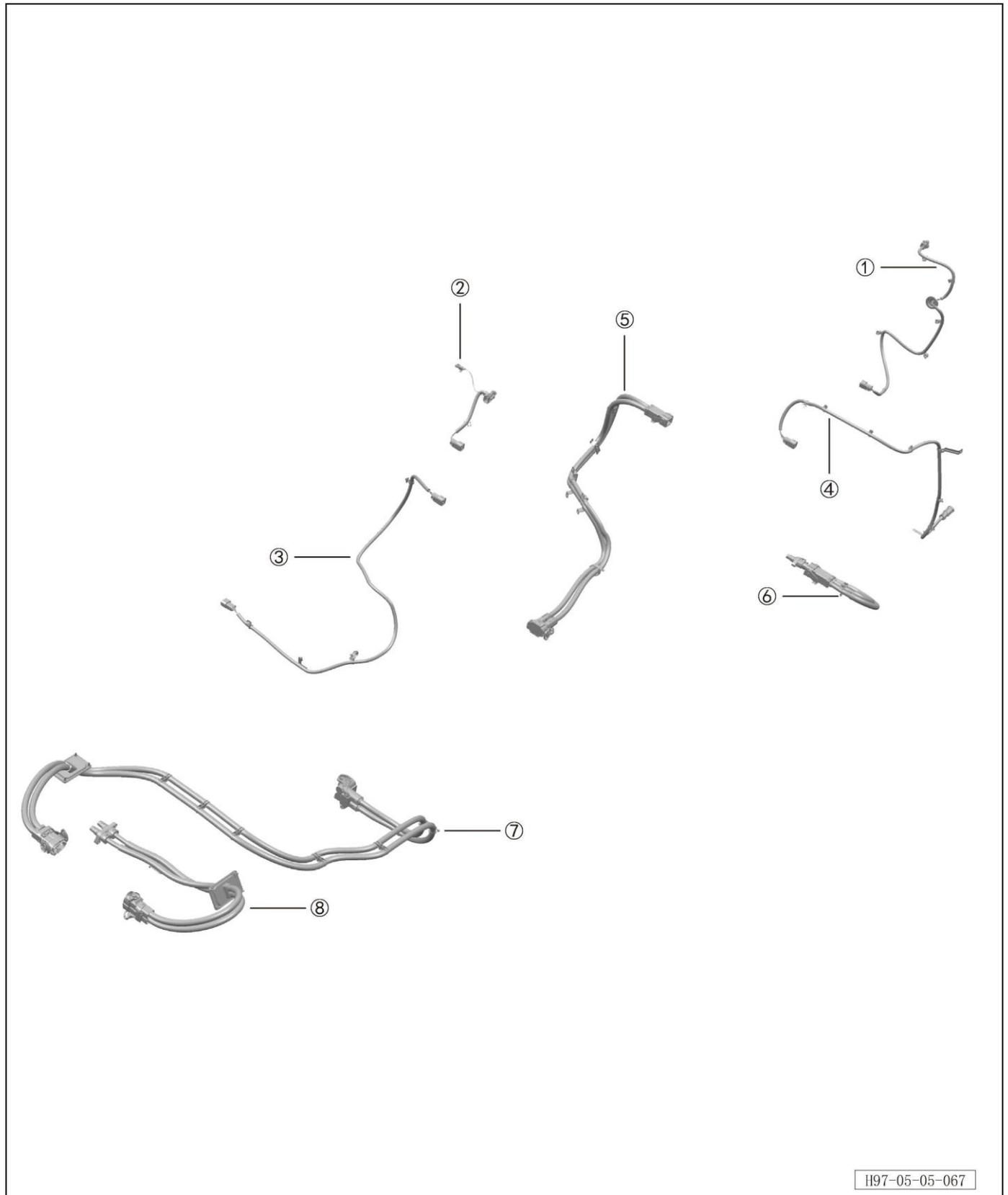

5.5.5 Exploded view of structure (EV)

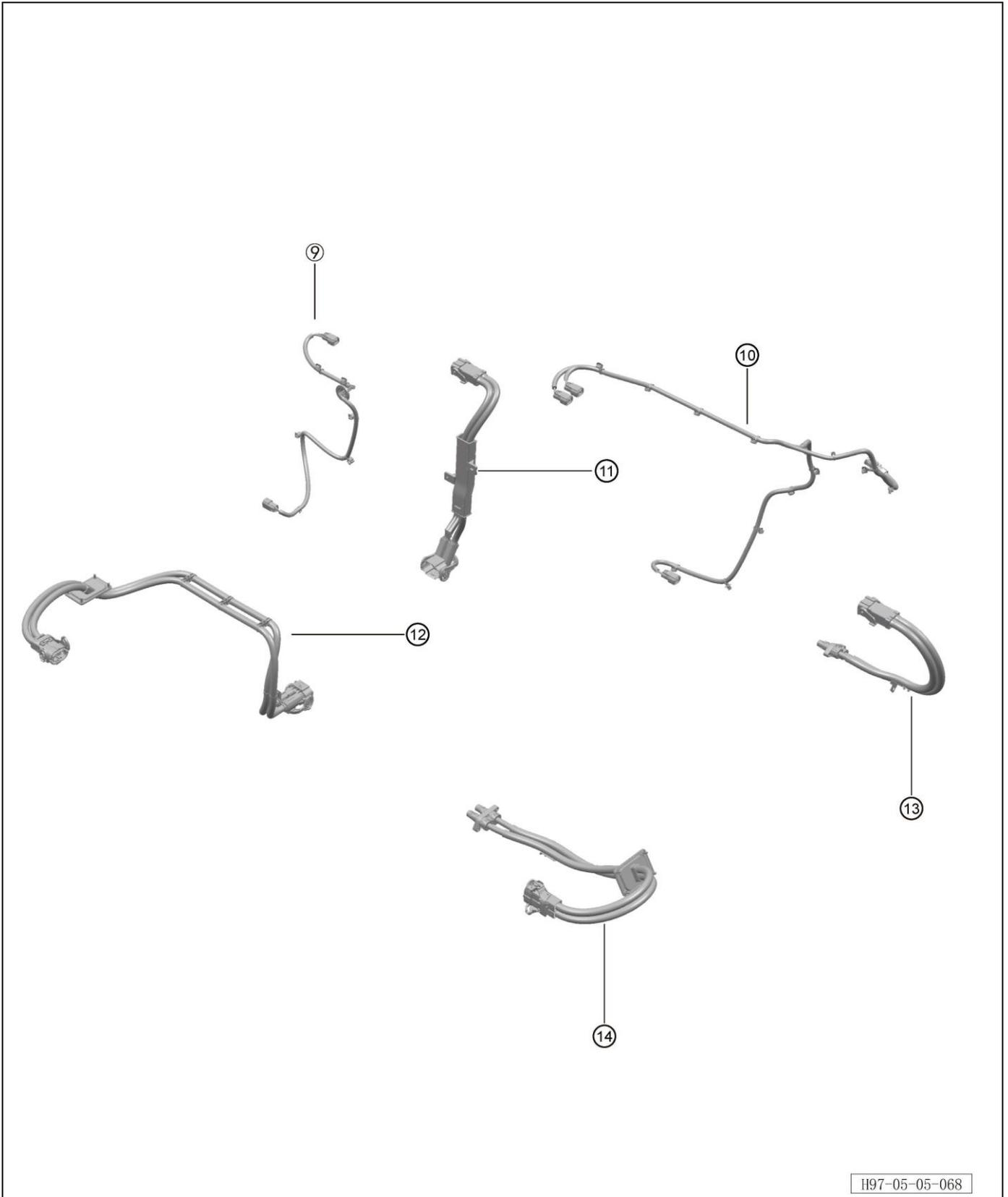

S/N	Part name	Loading quantity	Remarks
1	A/C PTC HV harness assembly	1	REV
2	A/C PTC HV harness assembly 2	1	REV
3	Battery PTC HV harness assembly	1	REV
4	Compressor high voltage harness assembly	1	REV
5	Compressor high voltage harness assembly	1	REV
6	Front motor high voltage harness assembly	1	REV
7	Battery pack rear high voltage harness assembly	1	REV
8	Rear motor high voltage harness assembly	1	REV
9	A/C PTC HV harness assembly	1	EV
10	Engine compartment battery heating PTC - compressor HV harness assembly	1	EV
11	Battery pack front high voltage harness assembly	1	EV
12	Battery pack rear high voltage harness assembly	1	EV
13	Front motor high voltage harness assembly	1	EV
14	Rear motor high voltage harness assembly	1	EV

5.5.6 Battery pack rear HV harness

5.5.6.1 Removal and refitting of battery pack rear HV harness assembly (REV)

Removal procedure

NOTE

- Take note of warnings and instructions for maintenance of the HV system. For details, refer to [5.5.1 Warnings and instructions for operations related to HV electronic control system](#).

1. Turn off all electrical appliances and the start switch.

2. Disconnect the battery negative terminal. Refer to [3.1.6.1 Maintenance and inspection battery](#)

3. Removing the trunk carpet assembly (refer to [8.5.8.1 Removal and refitting of trunk carpet assembly](#))

4. Remove battery pack rear HV harness assembly.

a. Disconnect OBC connector.

b. Unscrew 4 fixing bolts of HV harness.

Tightening torque of bolt: $8\pm 1\text{Nm}$.

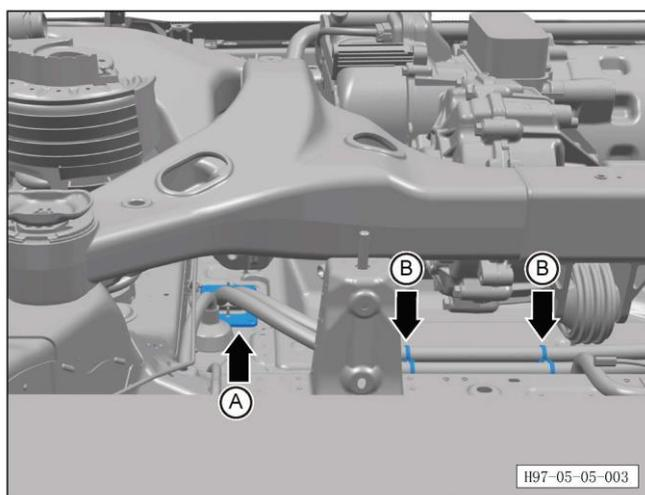
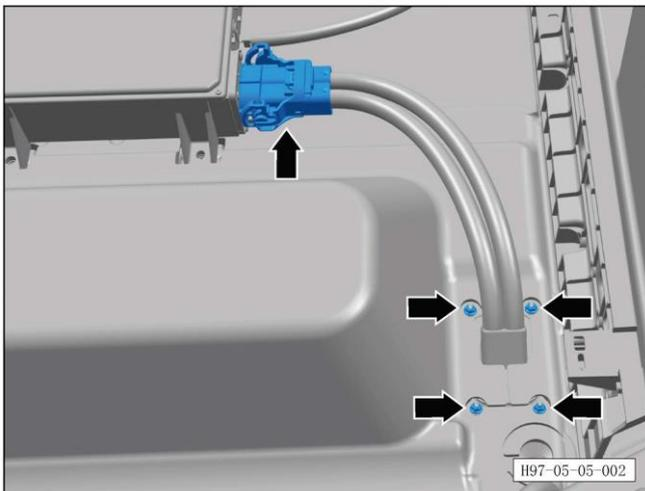

c. Remove the fixing rubber bush A of HV harness, and disengage 2 fixing clips B of HV harness.

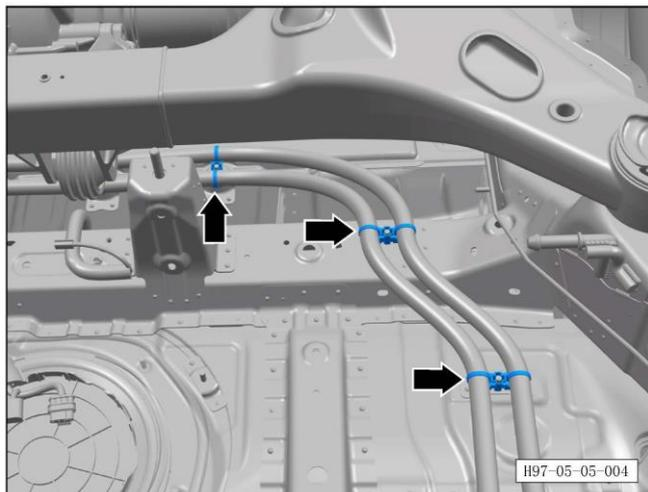

d. Disengage 3 fixing clips of HV harness.

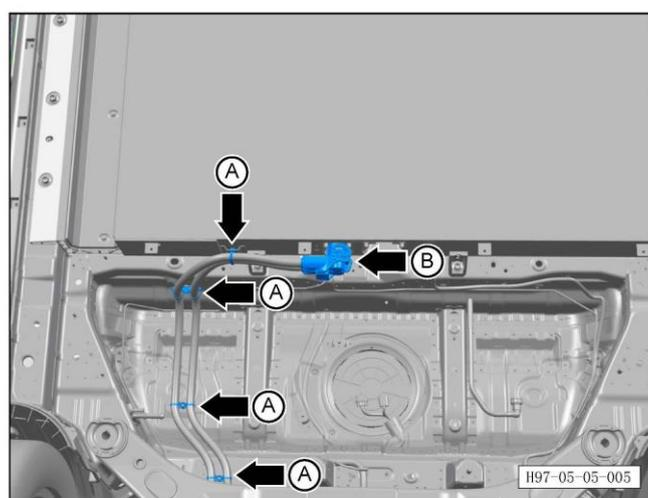

e. Disengage 4 fixing clips A of HV harness, and disconnect connector B of battery pack rear HV harness.

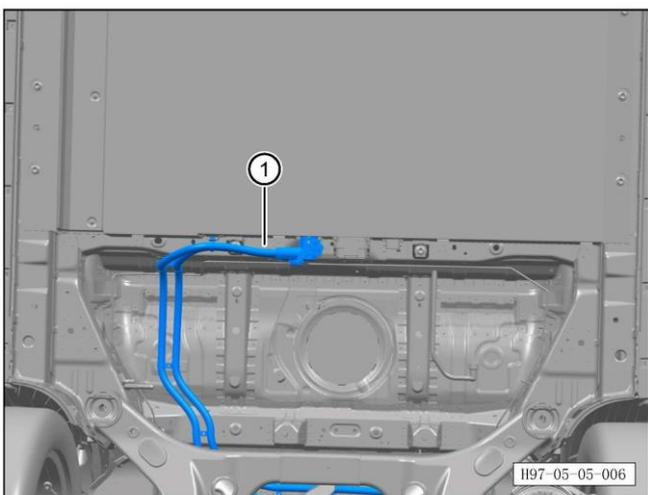

f. Remove battery pack rear HV harness assembly ①.

Refitting procedure

The refitting procedure is performed in reverse order.

5.5.6.2 Removal and refitting of battery pack rear HV harness assembly (EV)

Removal procedure

NOTE

- Take note of warnings and instructions for maintenance of the HV system. For details, refer to [5.5.1 Warnings and instructions for operations related to HV electronic control system](#).

1. Turn off all electrical appliances and the start switch.

2. Disconnect the battery negative terminal. Refer to [3.1.6.1 Maintenance and inspection battery](#)

3. Removing the trunk carpet assembly (refer to [8.5.8.1 Removal and refitting of trunk carpet assembly](#))

4. Remove battery pack rear HV harness assembly.

a. Disconnect 1 connector of OBC.

b. Unscrew 4 fixing bolts of HV harness.

Tightening torque of bolt: $8\pm 1\text{Nm}$.

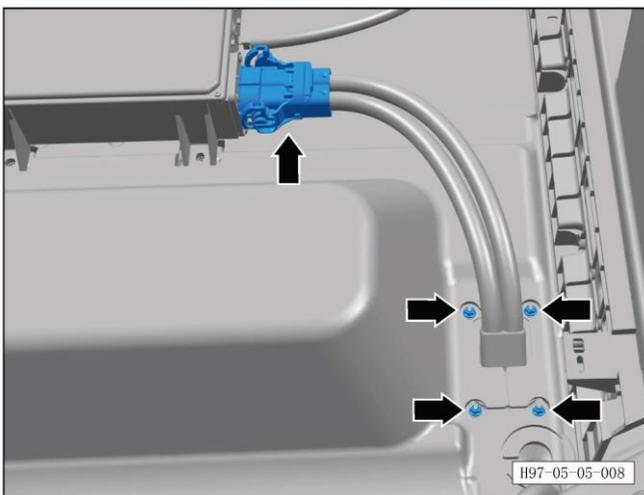

c. Remove the fixing rubber bush A of HV harness, and disengage 2 fixing clips B of HV harness.

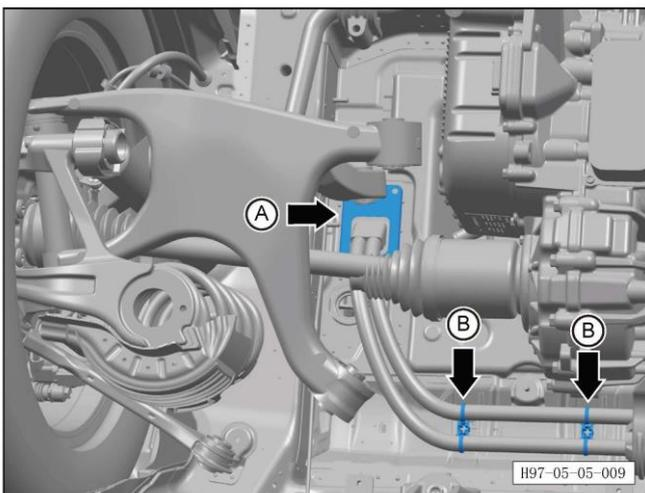

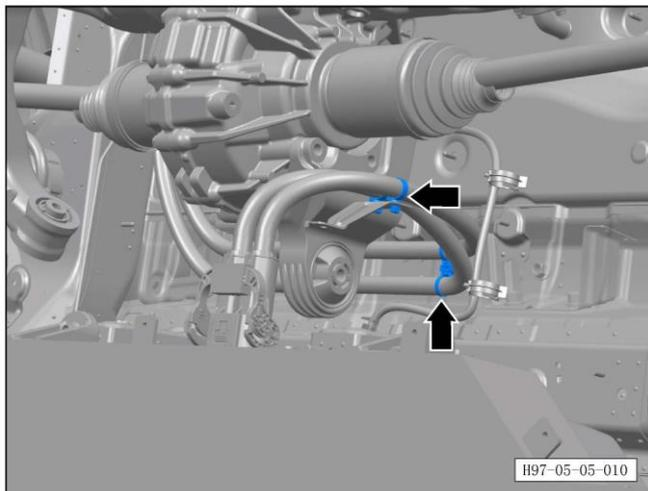

d. Disengage 2 fixing clips of HV harness.

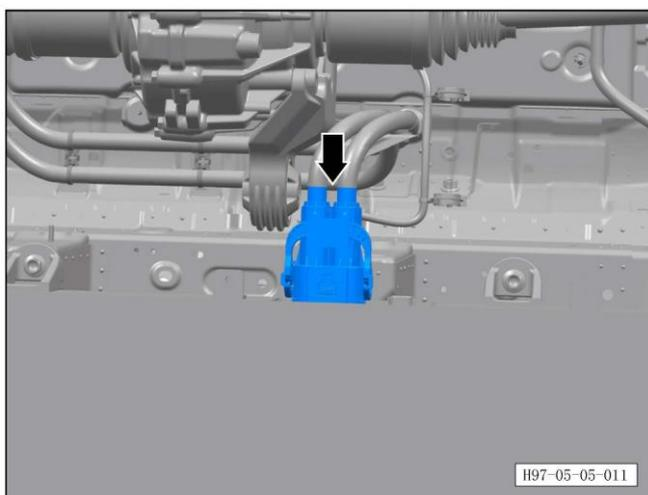

e. Disconnect battery pack rear HV harness connector.

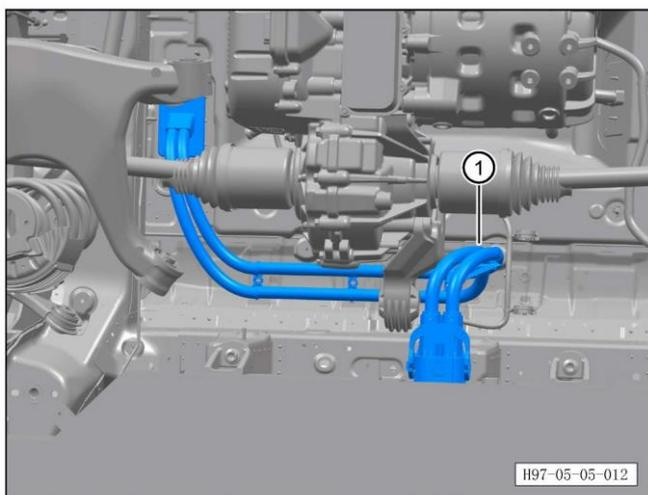

f. Remove battery pack rear HV harness assembly ①.

Refitting procedure

The refitting procedure is performed in reverse order.

5.5.7 Front motor HV harness

5.5.7.1 Removal and refitting of front motor HV harness assembly (REV)

Removal procedure

NOTE

- Take note of warnings and instructions for maintenance of the HV system. For details, refer to [5.5.1 Warnings and instructions for operations related to HV electronic control system](#).

1. Turn off all electrical appliances and the start switch.

2. Disconnect the battery negative terminal. Refer to [3.1.6.1 Maintenance and inspection battery](#)

3. Remove front subframe assembly (refer to [5.2.4.1 Removal and refitting of front subframe assembly](#))

4. Remove front motor HV harness assembly.

a. Unscrew 4 fixing bolts of front motor HV harness assembly bolt cover plate to detach the cover plate.

Tightening torque of bolt: $8\pm 1\text{Nm}$.

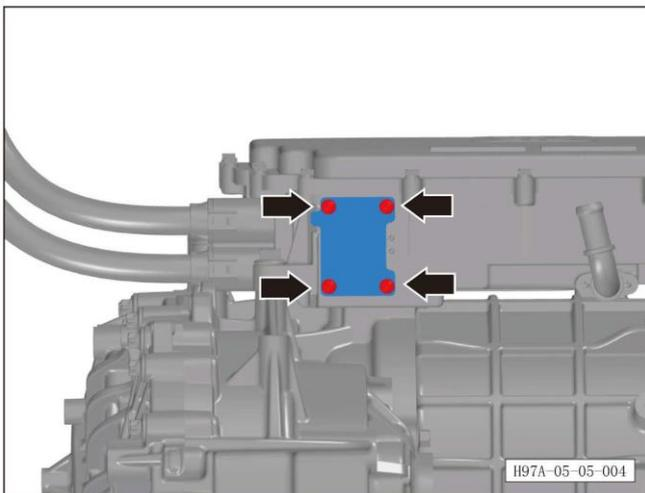

b. Unscrew 2 fixing bolts in front motor HV harness connector.

Tightening torque of bolt: $8\pm 1\text{Nm}$.

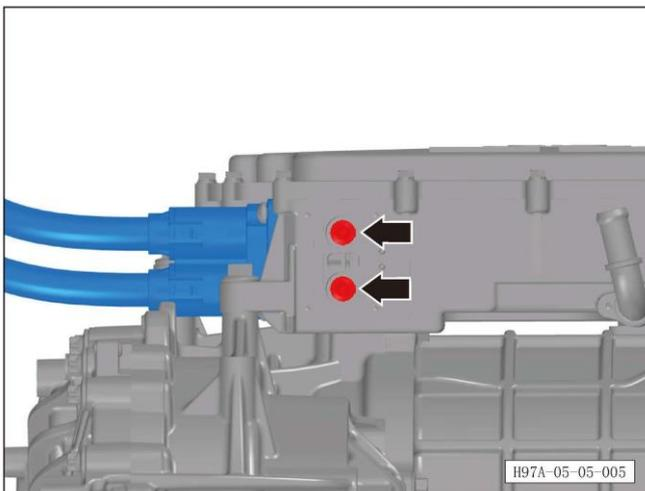

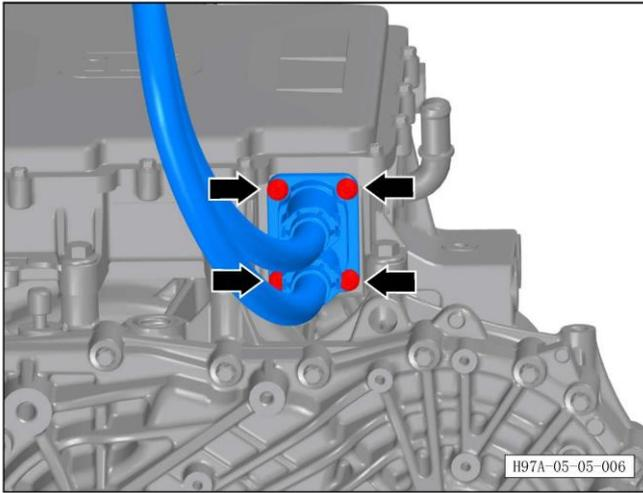

4. Unscrew 4 fixing bolts of front motor HV harness assembly to detach the front motor HV harness assembly.

Tightening torque of bolt: $8\pm 1\text{Nm}$.

Refitting procedure

The refitting procedure is performed in reverse order.

5.5.7.2 Removal and refitting of front motor HV harness assembly (EV)

Removal procedure

NOTE

- Take note of warnings and instructions for maintenance of the HV system. For details, refer to [5.5.1 Warnings and instructions for operations related to HV electronic control system](#).

1. Turn off all electrical appliances and the start switch.

2. Disconnect the battery negative terminal. Refer to [3.1.6.1 Maintenance and inspection battery](#)

3. Remove engine compartment item box assembly (refer to [8.5.11.1 Removal and refitting of engine compartment item box assembly](#))

4. Remove front motor HV harness assembly.

a. Disconnect 1 connector between front motor HV harness and engine compartment PDU.

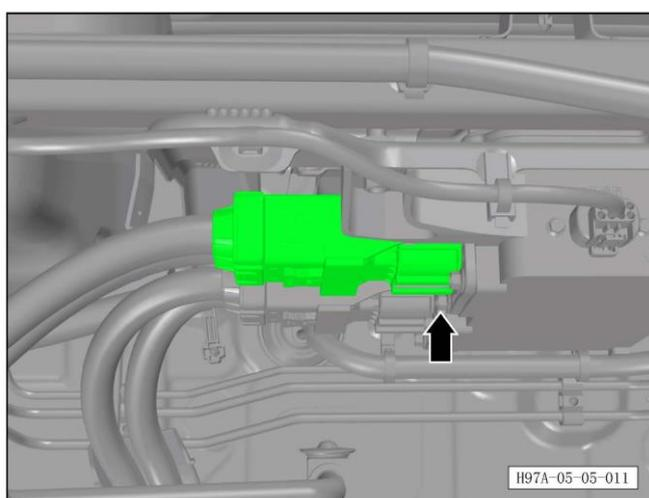

b. Unscrew 4 fixing bolts of front motor HV harness assembly bolt cover plate to detach the cover plate.

Tightening torque of bolt: $8\pm 1\text{Nm}$.

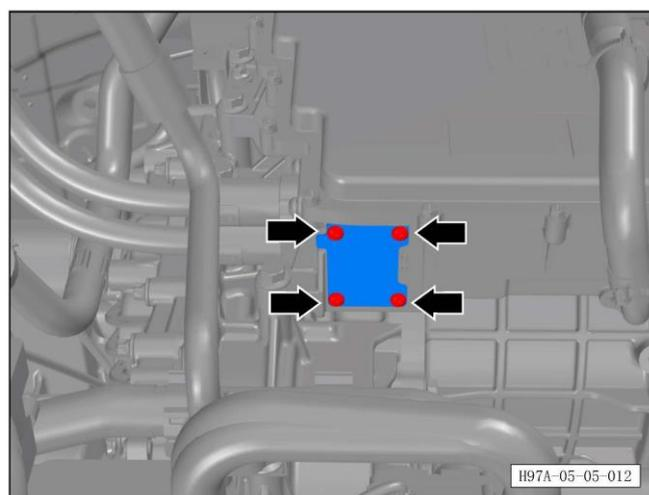

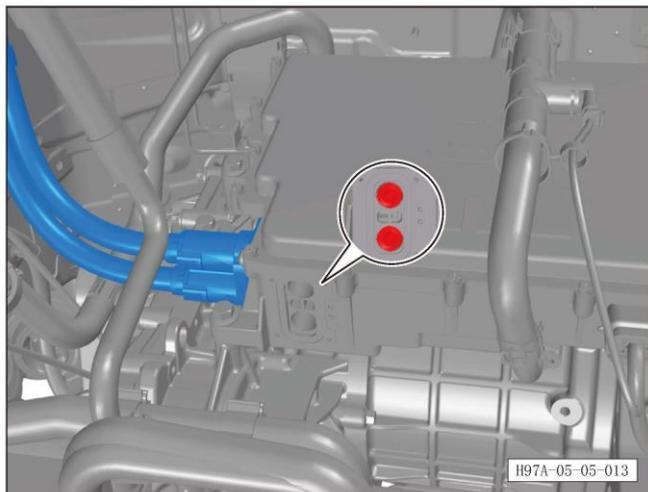

c. Unscrew 2 fixing bolts in front motor HV harness connector.

Tightening torque of bolt: $8\pm 1\text{Nm}$.

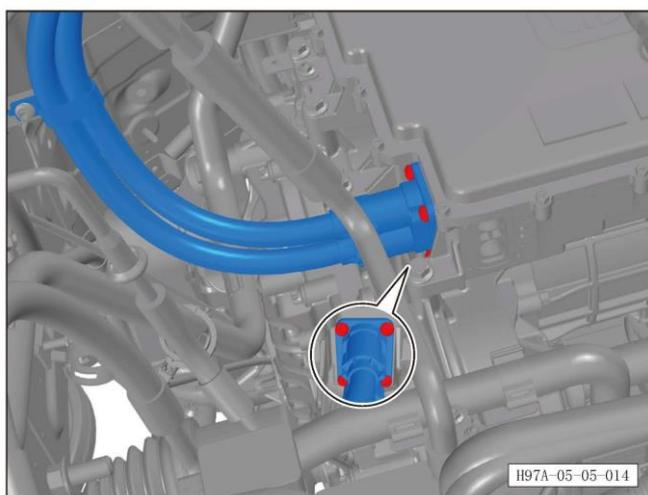

d. Unscrew 4 fixing bolts of front motor HV harness assembly.

Tightening torque of bolt: $8\pm 1\text{Nm}$.

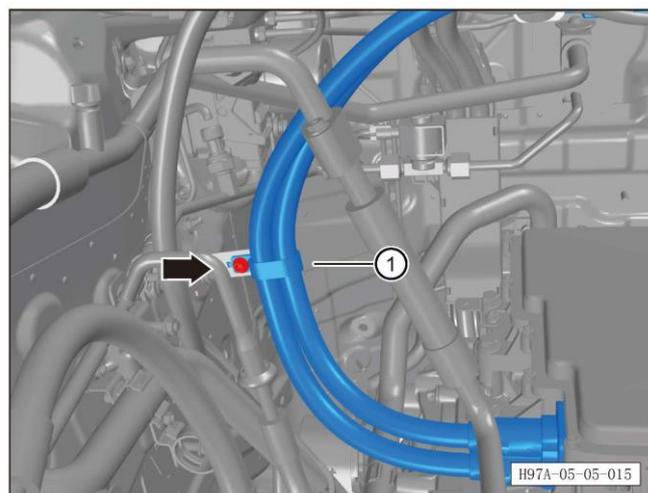

d. Unscrew 1 fixing bolt between the front motor HV harness assembly and the body to detach the front motor HV harness assembly ①.

Tightening torque of bolt: $8\pm 1\text{Nm}$.

Refitting procedure

The refitting procedure is performed in reverse order.

5.5.8 Rear motor HV harness

5.5.8.1 Removal and refitting of rear motor HV harness assembly

Removal procedure

NOTE

- Take note of warnings and instructions for maintenance of the HV system. For details, refer to [5.5.1 Warnings and instructions for operations related to HV electronic control system](#).

1. Turn off all electrical appliances and the start switch.
2. Disconnect the battery negative terminal. Refer to [3.1.6.1 Maintenance and inspection battery](#)
3. Removing the trunk carpet assembly (refer to [8.5.8.1 Removal and refitting of trunk carpet assembly](#))
4. Remove rear drive motor assembly (refer to [5.2.5.3 Removal and refitting of rear drive motor assembly](#))
5. Remove rear motor HV harness assembly.

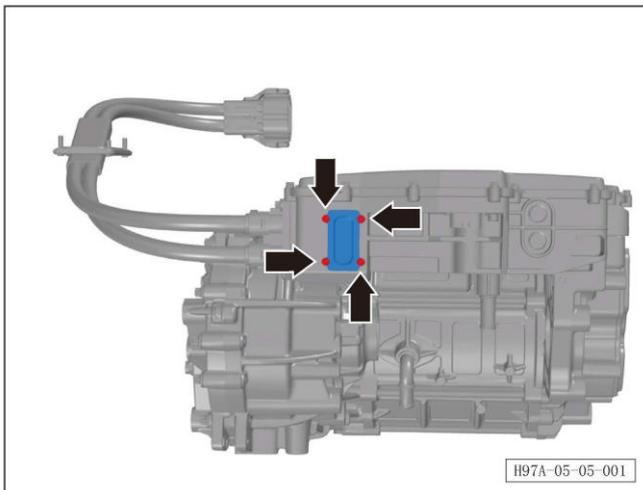

- a. Unscrew 4 fixing bolts of rear motor HV harness assembly bolt cover plate to detach the cover plate.

Tightening torque of bolt: $8\pm 1\text{Nm}$.

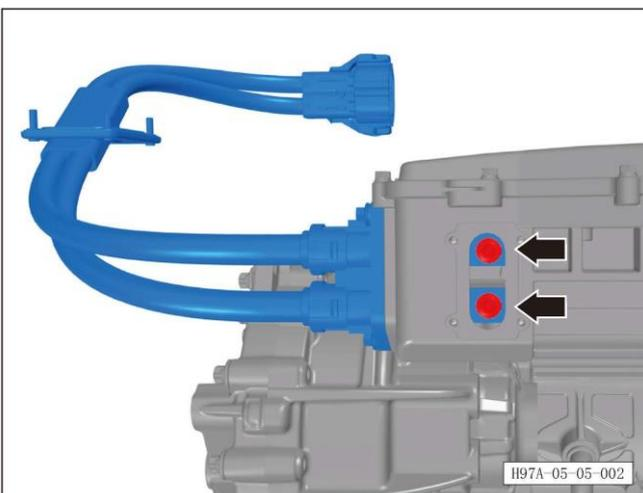

- b. Unscrew 2 fixing bolts in rear motor HV harness connector.

Tightening torque of bolt: $8\pm 1\text{Nm}$.

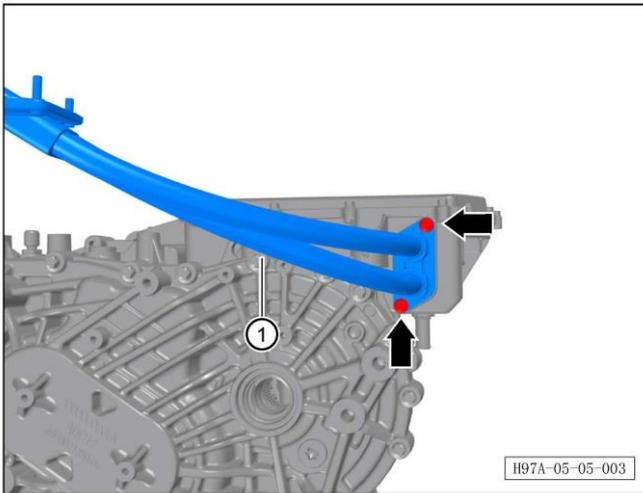

c. Unscrew 2 fixing bolts of rear motor HV harness assembly to detach the rear motor HV harness assembly ①.

Tightening torque of bolt: $8\pm 1\text{Nm}$.

Refitting procedure

The refitting procedure is performed in reverse order.

5.5.9 PTC HV harness

5.5.9.1 Removal and refitting of A/C PTC HV harness assembly (REV)

Removal procedure

NOTE

- Take note of warnings and instructions for maintenance of the HV system. For details, refer to [5.5.1 Warnings and instructions for operations related to HV electronic control system](#).

1. Turn off all electrical appliances and the start switch.

2. Disconnect the battery negative terminal. Refer to [3.1.6.1 Maintenance and inspection battery](#)

3. Remove the engine hood assembly (refer to [7.1.3.1 Removal and refitting of engine hood assembly](#))

4. Remove A/C PTC HV harness assembly.

a. Disconnect A/C PTC HV harness connector A and disengage 2 HV harness clips B.

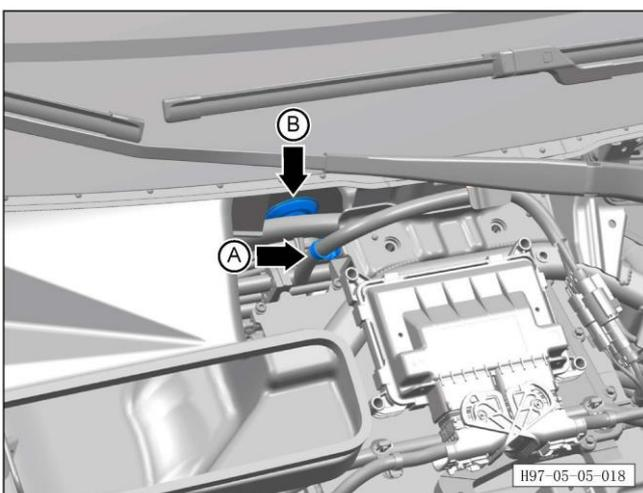
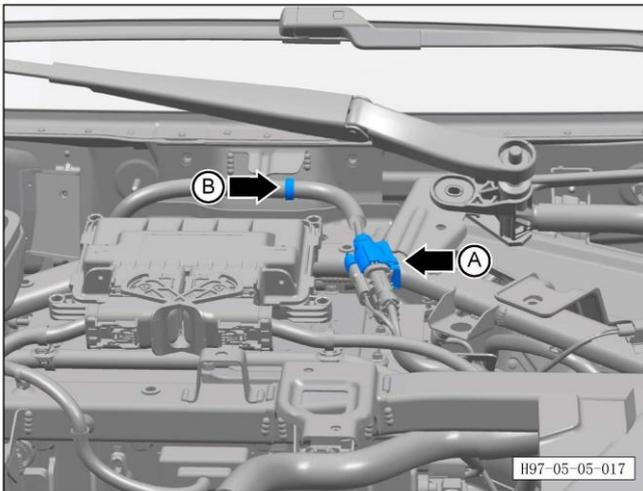

b. Disengage 2 HV harness clips A, and remove the HV harness rubber bush B.

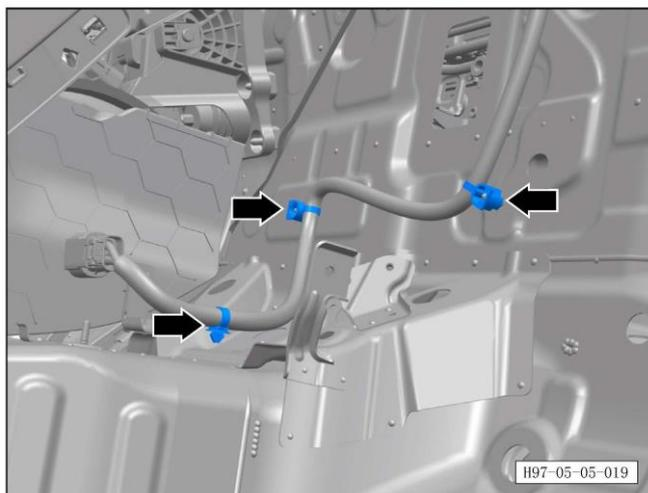

c. Disengage 3 HV harness clips.

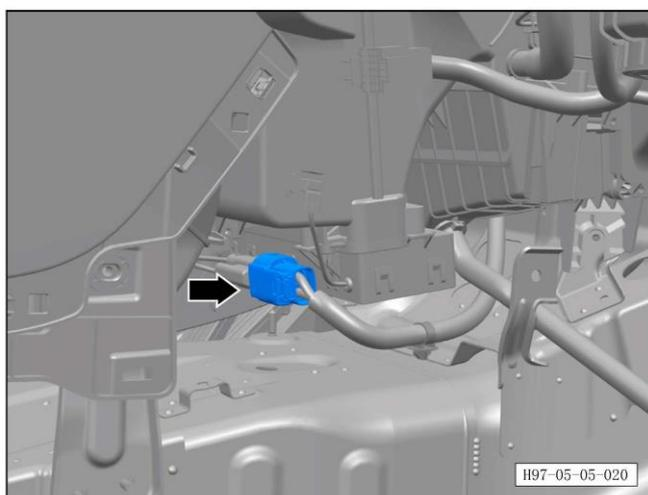

d. Disconnect HAVC connector.

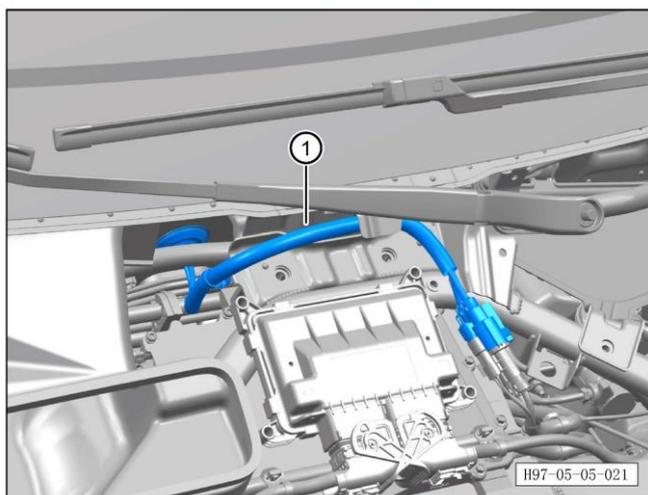

e. Remove A/C PTC HV harness assembly ①.

Refitting procedure

The refitting procedure is performed in reverse order.

5.5.9.2 Removal and refitting of A/C PTC HV harness assembly 2 (REV)

Removal procedure

NOTE

- Take note of warnings and instructions for maintenance of the HV system. For details, refer to [5.5.1 Warnings and instructions for operations related to HV electronic control system](#).

1. Turn off all electrical appliances and the start switch.
2. Disconnect the battery negative terminal. Refer to [3.1.6.1 Maintenance and inspection battery](#)
3. Remove the engine hood assembly (refer to [7.1.3.1 Removal and refitting of engine hood assembly](#))
4. Remove A/C PTC HV harness assembly 2.

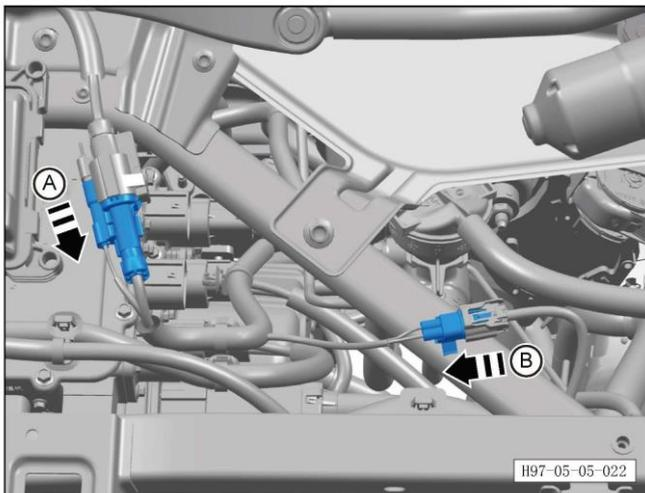

- a. Disconnect A/C PTC HV harness connector A (in the direction as indicated by the arrow) and engine harness connector B (in the direction as indicated by the arrow).

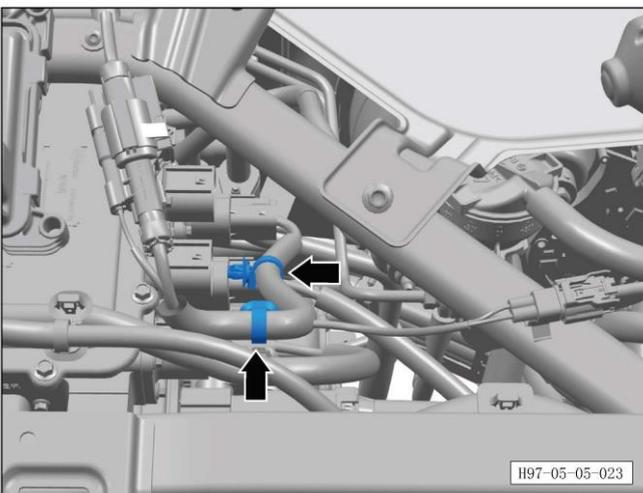

- b. Disengage 2 fixing clips of HV harness.

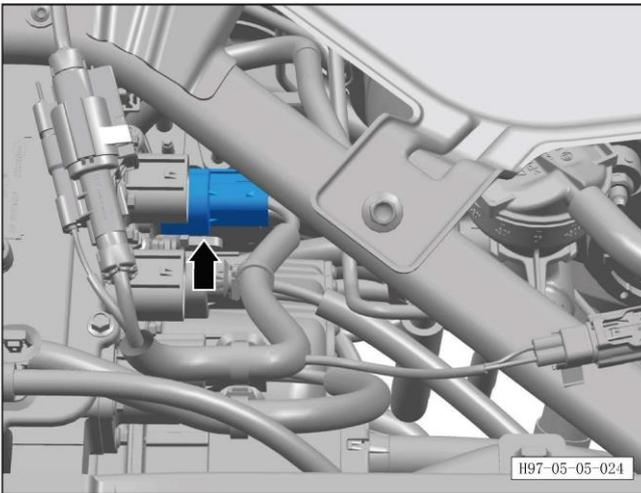

c. Disconnect engine compartment PDU connector.

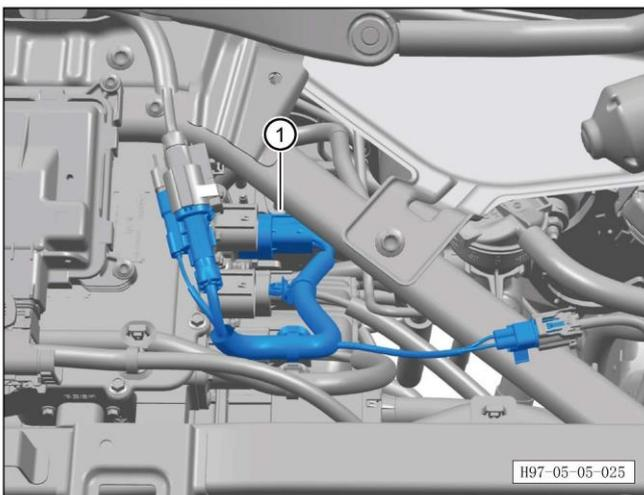

d. Remove A/C PTC HV harness assembly 2 ①.

Refitting procedure

The refitting procedure is performed in reverse order.

5.5.9.3 Removal and refitting of A/C PTC HV harness assembly (EV)

Removal procedure

NOTE

- Take note of warnings and instructions for maintenance of the HV system. For details, refer to [5.5.1 Warnings and instructions for operations related to HV electronic control system](#).

1. Turn off all electrical appliances and the start switch.

2. Disconnect the battery negative terminal. Refer to [3.1.6.1 Maintenance and inspection battery](#)

3. Remove front drive motor assembly (refer to [5.4.4.2 Removal and refitting of engine compartment PDU assembly \(EV\)](#))

4. Remove A/C PTC HV harness assembly.

a. Disconnect A/C PTC HV harness connector A and disengage 1 HV harness clips B.

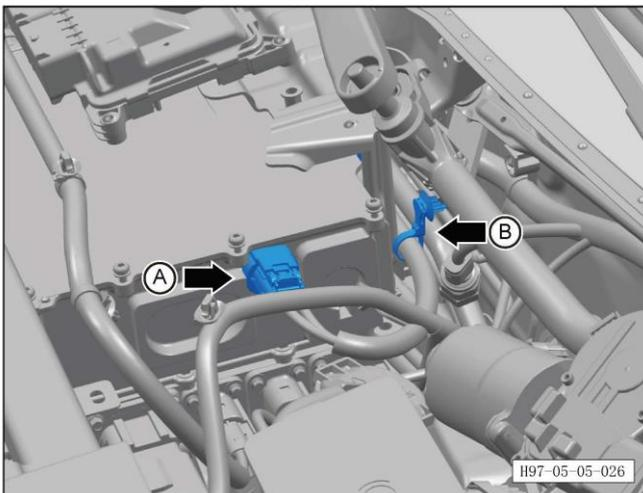

b. Disengage 1 HV harness clips A, and remove the HV harness rubber bush B.

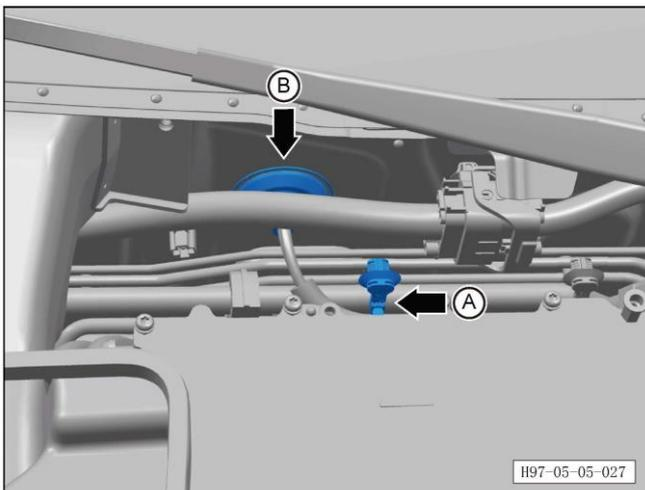

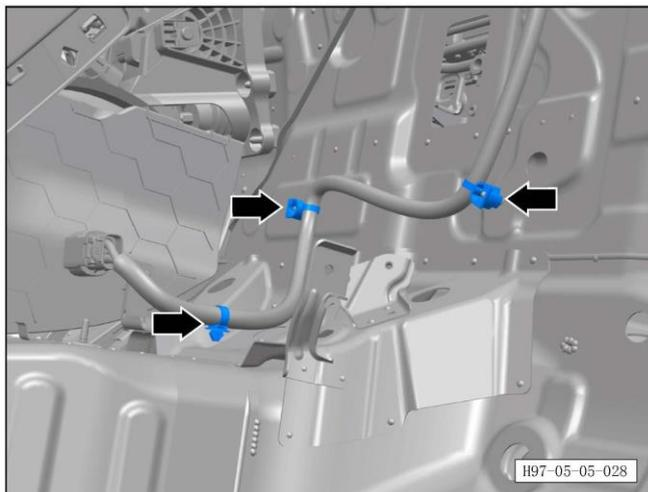

c. Disengage 3 HV harness clips.

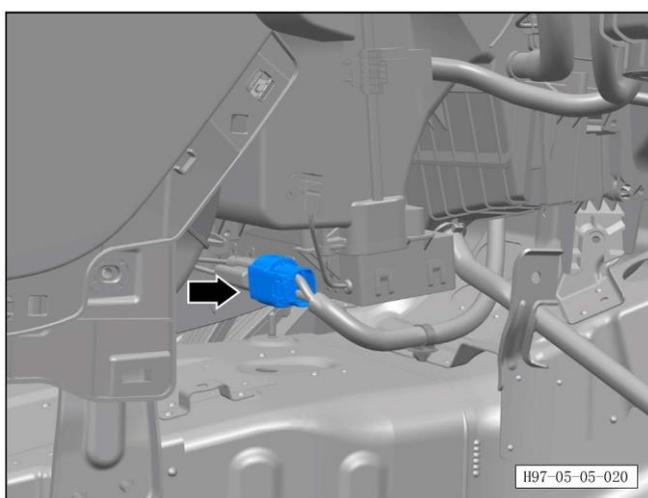

d. Disconnect HAVC connector.

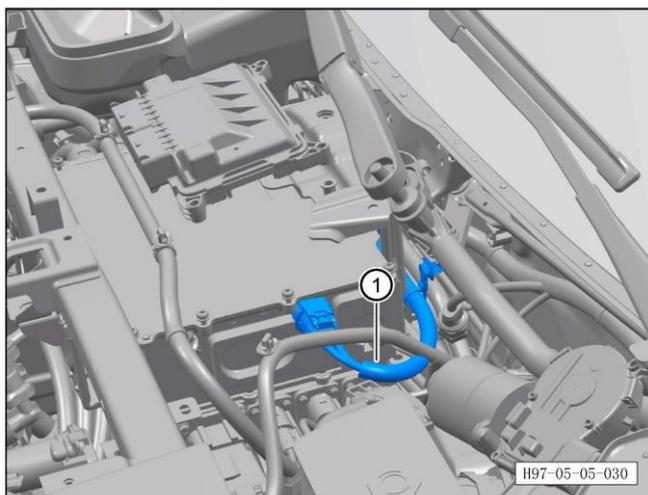

e. Remove A/C PTC HV harness assembly ①.

Refitting procedure

The refitting procedure is performed in reverse order.

5.5.9.4 Removal and refitting of engine compartment battery heating PTC - compressor HV harness assembly (EV)

Removal procedure

NOTE

- Take note of warnings and instructions for maintenance of the HV system. For details, refer to [5.5.1 Warnings and instructions for operations related to HV electronic control system](#).

1. Turn off all electrical appliances and the start switch.

2. Disconnect the battery negative terminal. Refer to [3.1.6.1 Maintenance and inspection battery](#)

3. Remove front drive motor assembly (refer to [5.2.3.1 Removal and refitting of front drive motor assembly \(EV\)](#))

4. Remove engine compartment battery heating PTC - compressor HV harness assembly.

a. Disconnect HV harness connector A, and disengage 2 HV harness clips B.

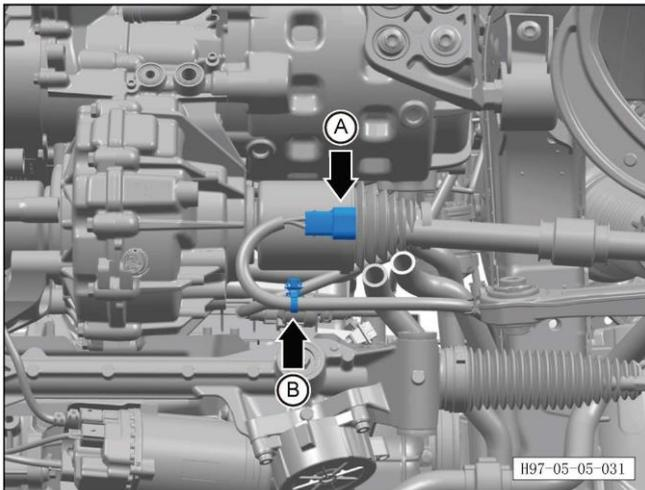

b. Disengage 2 HV harness clips.

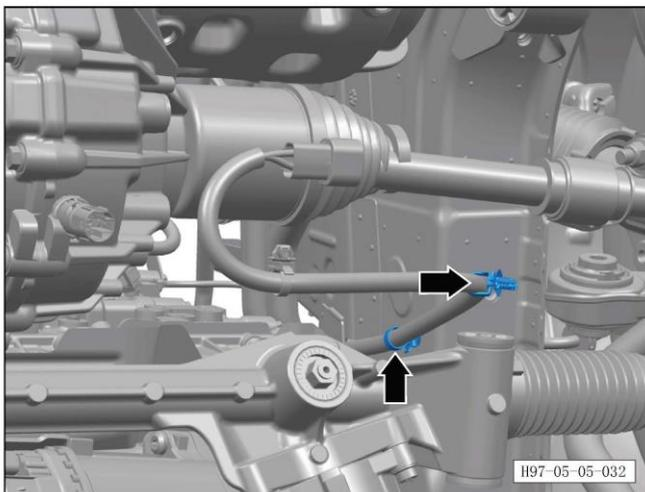

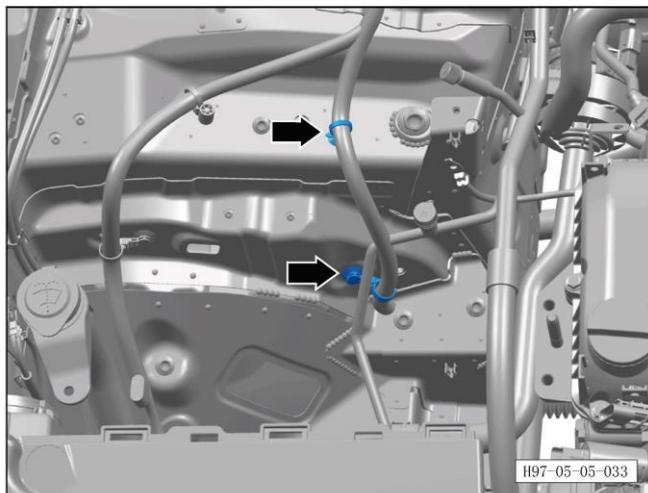

c. Disengage 2 HV harness clips.

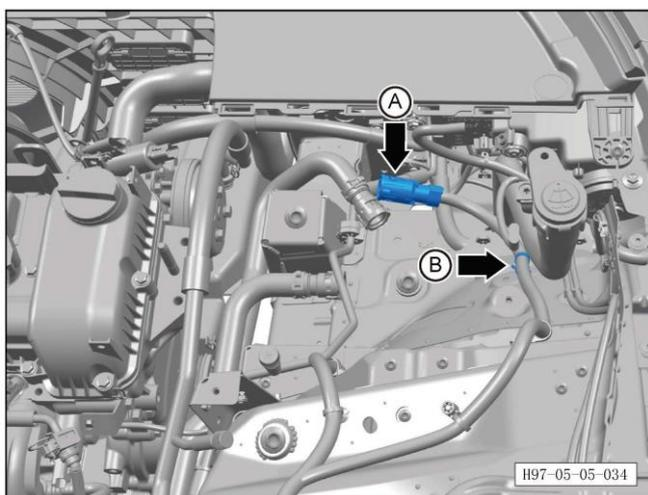

d. Disengage 2 HV harness connectors A, and disengage 2 HV harness clips B.

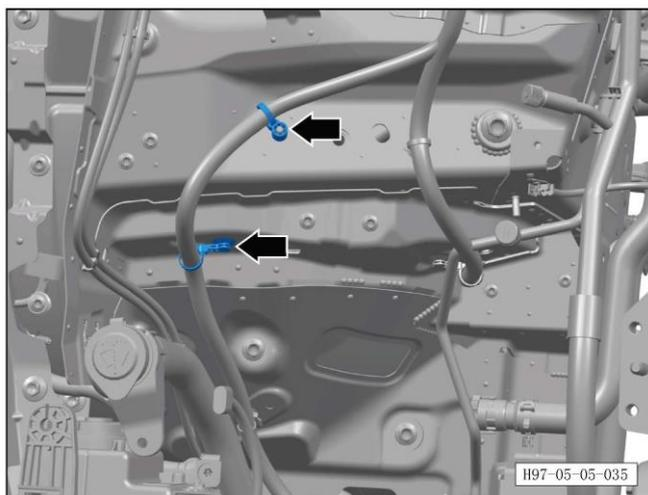

e. Disengage 2 HV harness clips.

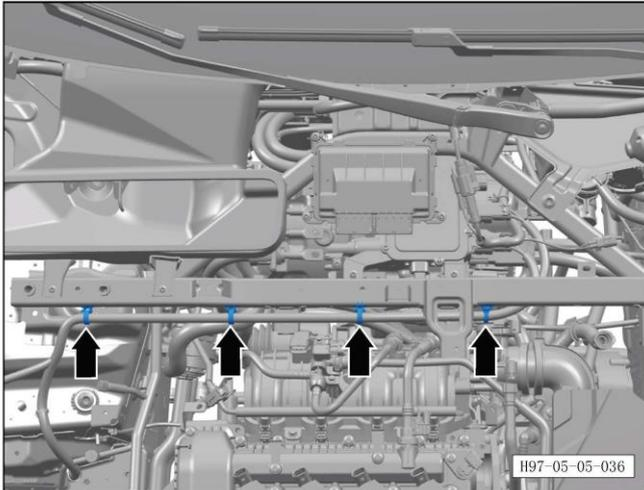

f. Disengage 4 HV harness clips.

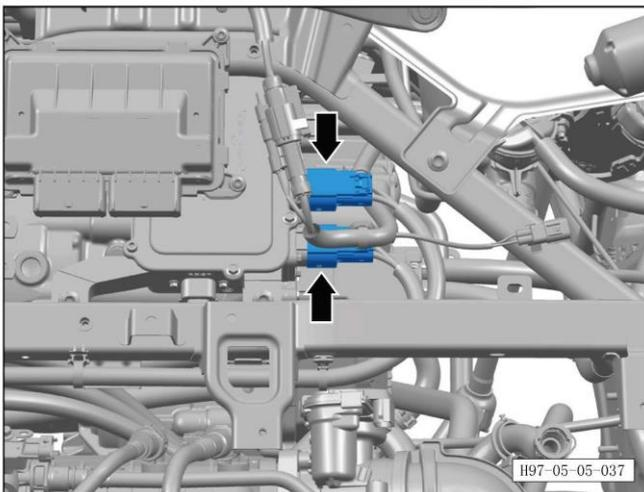

g. Disconnect 2 connectors of engine compartment PDU.

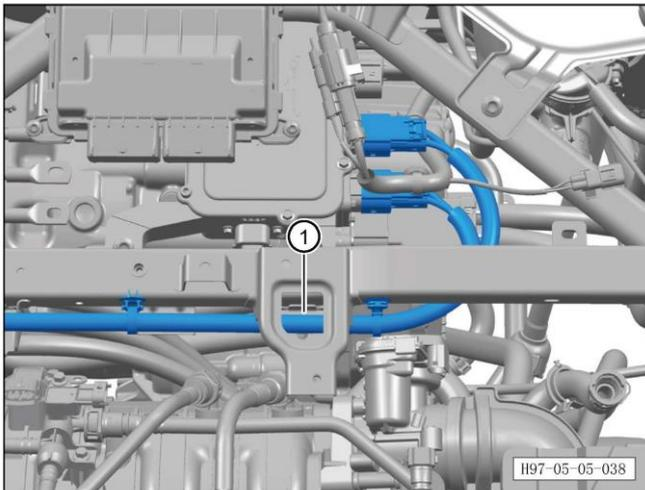

h. Remove engine compartment battery PTC - compressor HV harness assembly.

Refitting procedure

The refitting procedure is performed in reverse order.

5.5.9.5 Removal and refitting of battery PTC HV harness assembly

Removal procedure

NOTE

- Take note of warnings and instructions for maintenance of the HV system. For details, refer to [5.5.1 Warnings and instructions for operations related to HV electronic control system](#).

1. Turn off all electrical appliances and the start switch.
2. Disconnect the battery negative terminal. Refer to [3.1.6.1 Maintenance and inspection battery](#)
3. Remove the engine hood assembly (refer to [7.1.3.1 Removal and refitting of engine hood assembly](#))
4. Remove battery PTC HV harness assembly.

a. Disconnect HV harness connector.

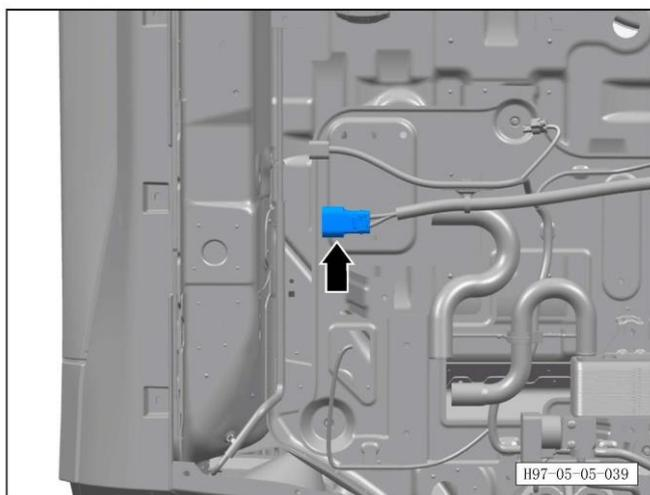

b. Disengage 3 HV harness clips.

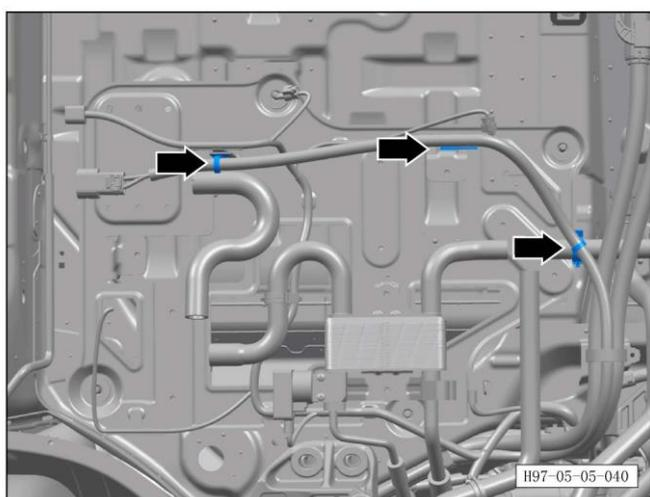

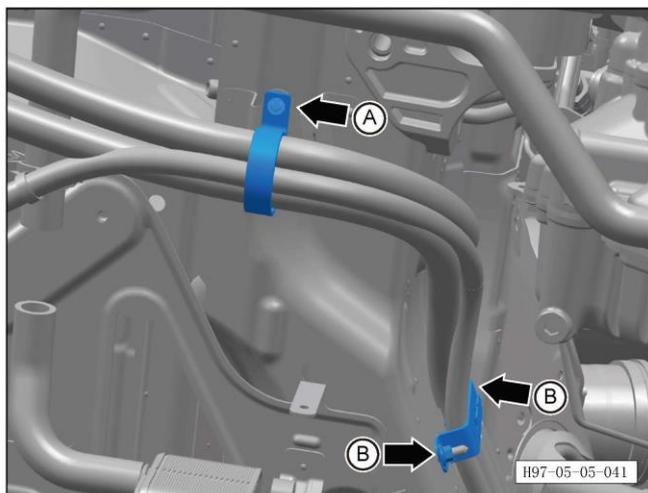

c. Unscrew bolt A and 2 nuts B of HV harness fixing bracket.

Tightening torque of bolt A: $8\pm 1\text{Nm}$.

Tightening torque of nut B: $8\pm 1\text{Nm}$.

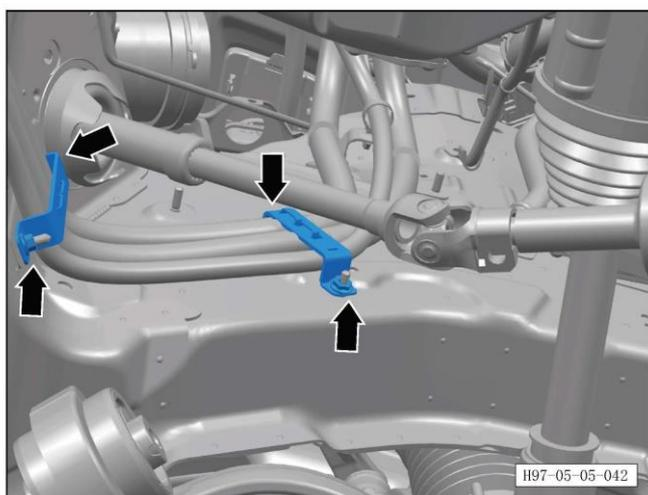

d. Unscrew 4 nuts of HV harness fixing bracket.

Tightening torque of nut: $8\pm 1\text{Nm}$.

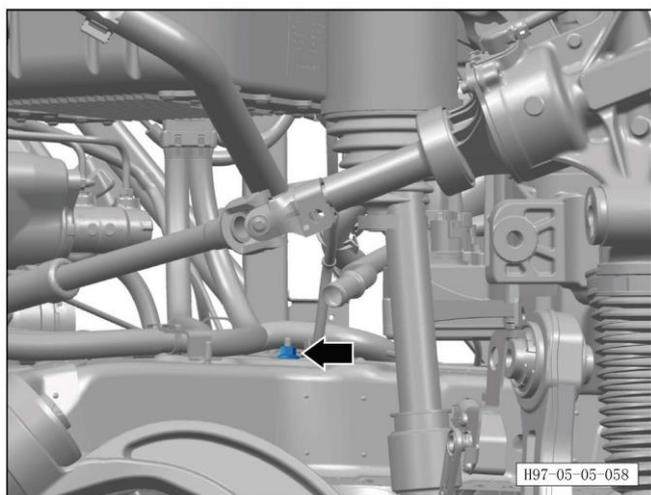

e. Unscrew the nut of HV harness fixing bracket.

Tightening torque of nut: $8\pm 1\text{Nm}$.

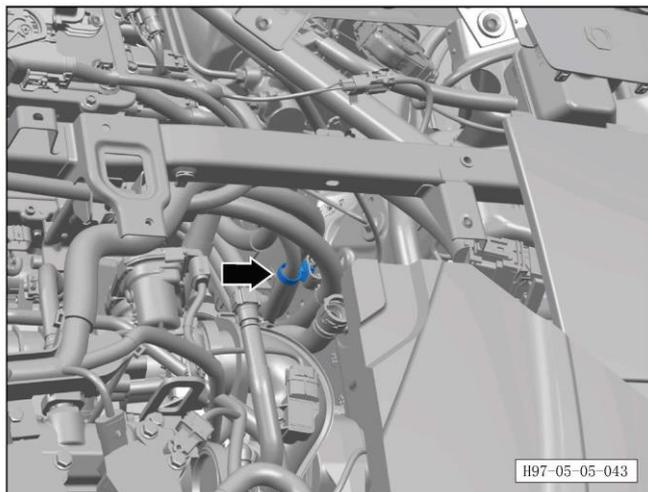

d. Disengage HV harness clip.

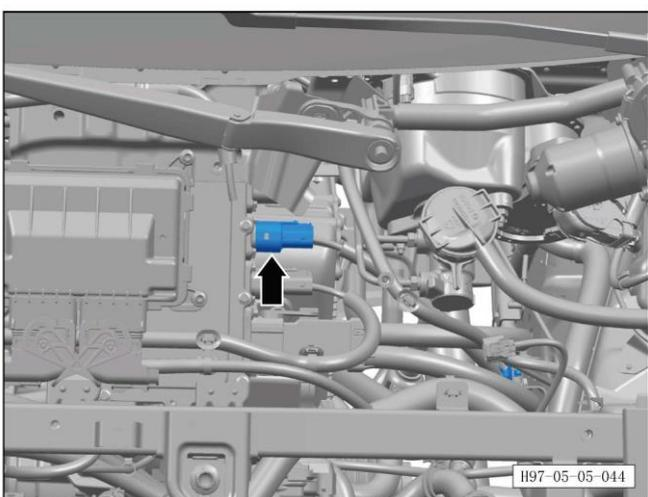

g. Disconnect engine compartment PDU connector.

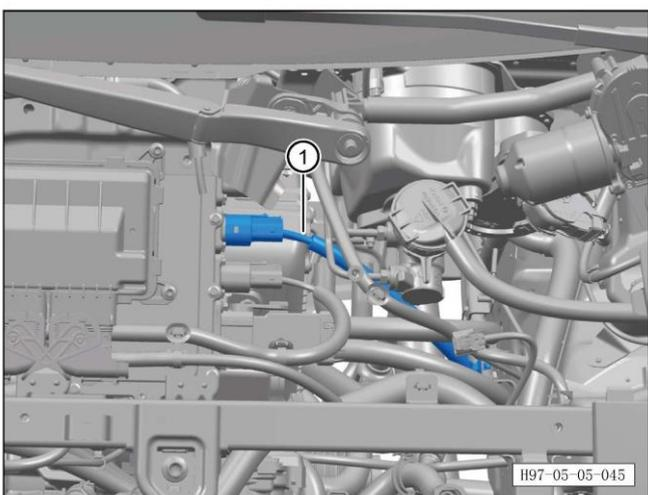

h. Remove battery PTC HV harness assembly ①.

Refitting procedure

The refitting procedure is performed in reverse order.

5.5.10 Compressor HV harness

5.5.10.1 Removal and refitting of compressor HV harness assembly

Removal procedure

NOTE

- Take note of warnings and instructions for maintenance of the HV system. For details, refer to [5.5.1 Warnings and instructions for operations related to HV electronic control system](#).

1. Turn off all electrical appliances and the start switch.

2. Disconnect the battery negative terminal. Refer to [3.1.6.1 Maintenance and inspection battery](#)

3. Remove engine hood assembly (refer to [7.1.3.1 Removal and refitting of engine hood assembly](#))

4. Remove compressor HV harness assembly.

a. Disconnect compressor connector.

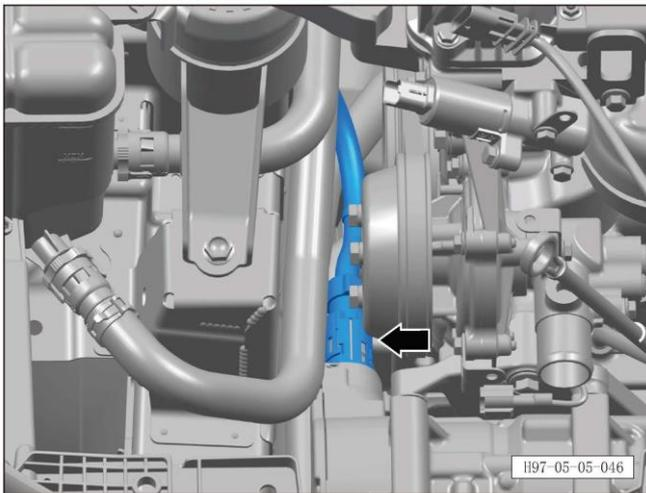

b. Disengage 2 HV harness clips.

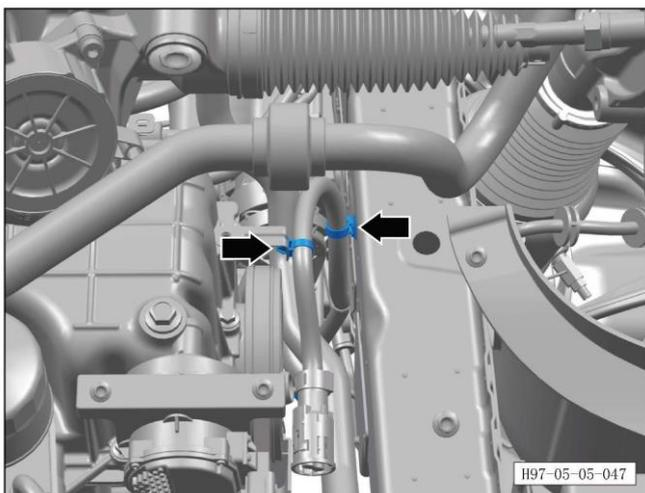

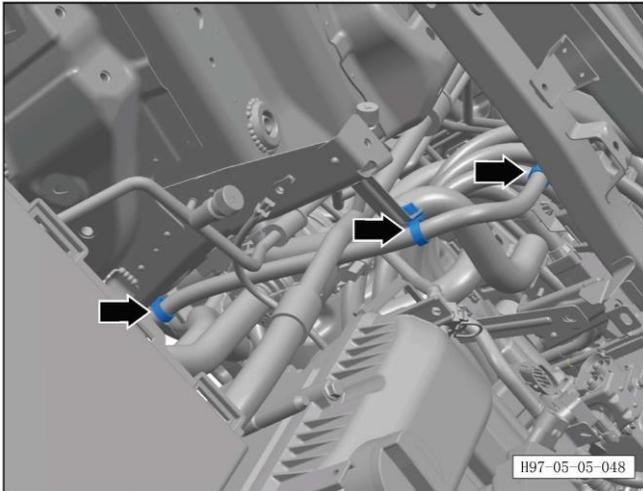

c. Disengage 3 HV harness clips.

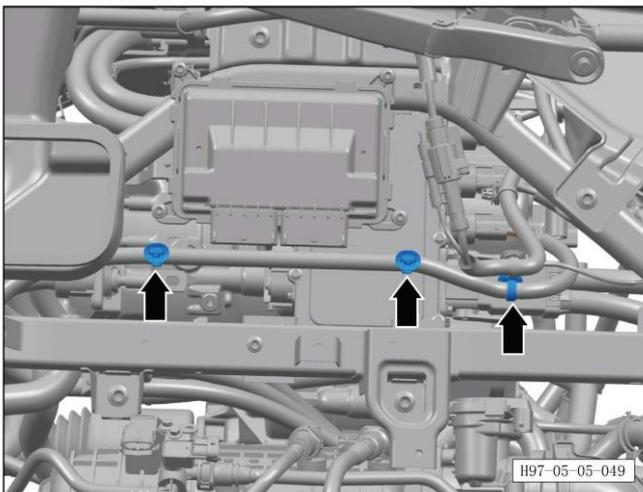

d. Disengage 3 HV harness clips.

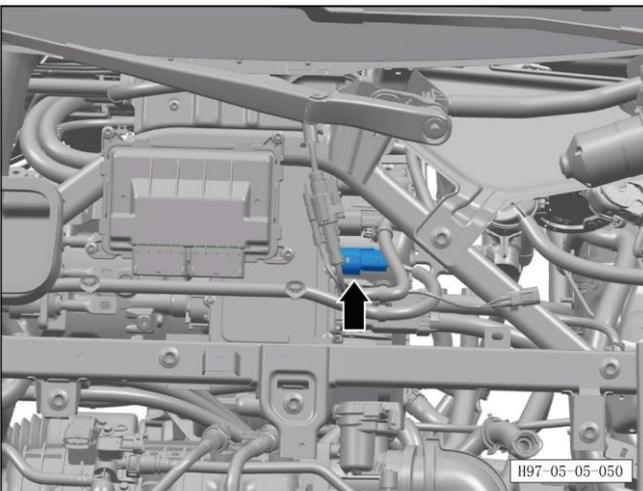

e. Disconnect engine compartment PDU connector.

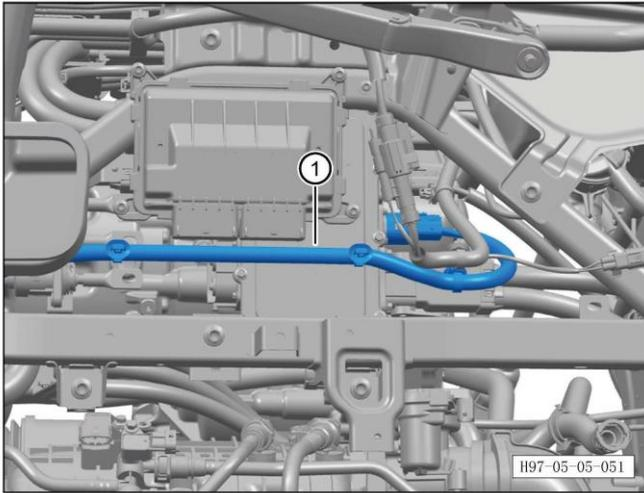

f. Remove compressor HV harness assembly ①.

Refitting procedure

The refitting procedure is performed in reverse order.

5.5.11 Battery pack front HV harness

5.5.11.1 Removal and refitting of battery pack front HV harness assembly (REV)

Removal procedure

NOTE

- Take note of warnings and instructions for maintenance of the HV system. For details, refer to [5.5.1 Warnings and instructions for operations related to HV electronic control system](#).

1. Turn off all electrical appliances and the start switch.
2. Disconnect the battery negative terminal. Refer to [3.1.6.1 Maintenance and inspection battery](#)
3. Remove the middle lower protective plate (refer to [8.6.4.5 Removal and refitting of middle lower protective plate \(REV\)](#))
4. Remove battery pack front HV harness assembly.
 - a. Disconnect battery pack connector.

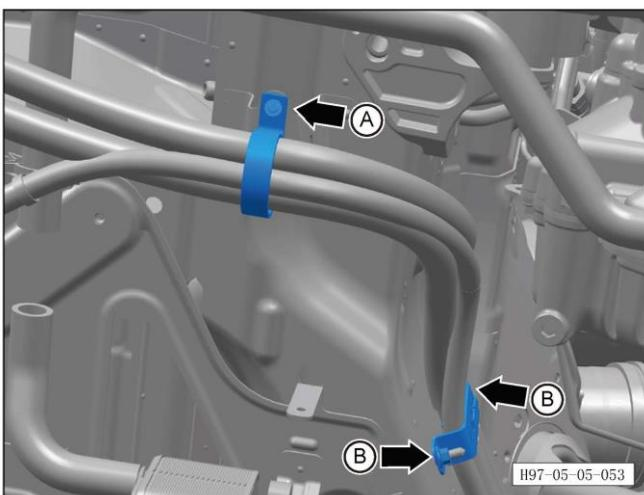
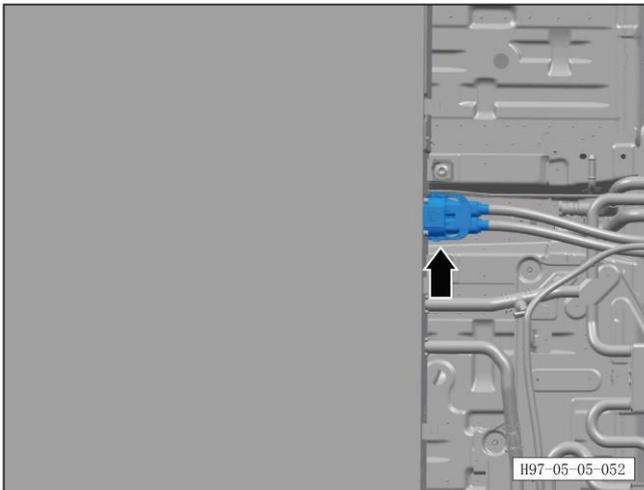

- b. Unscrew bolt A and 2 nuts B of HV harness fixing bracket.

Tightening torque of bolt A: $8\pm 1\text{Nm}$.

Tightening torque of nut B: $8\pm 1\text{Nm}$.

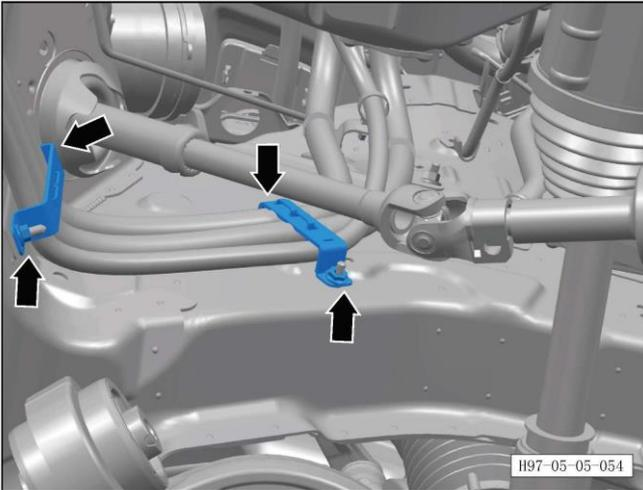

c. Unscrew 4 nuts B of HV harness fixing bracket.
Tightening torque of nut: $8\pm 1\text{Nm}$.

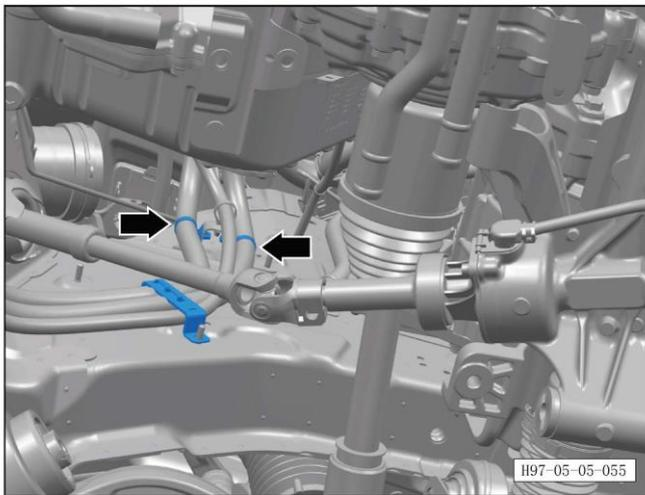

d. Disengage 2 HV harness clips.

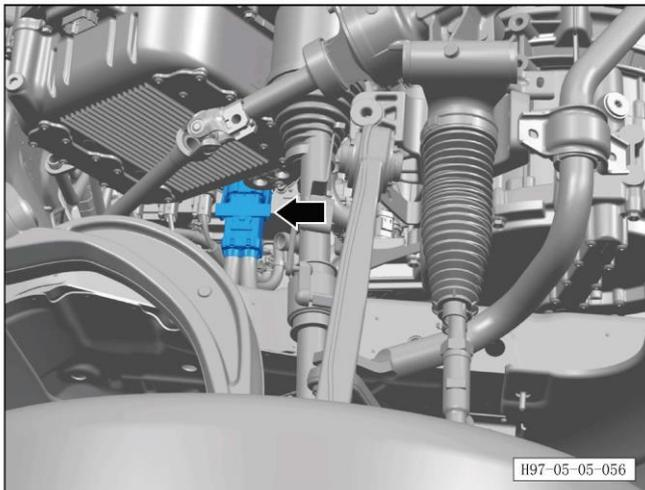

e. Disconnect engine compartment PDU connector.

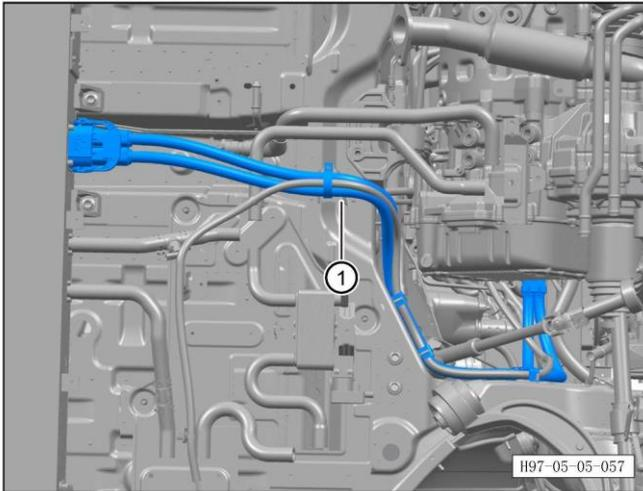

- f. Remove battery pack front HV harness assembly
①.

Refitting procedure

The refitting procedure is performed in reverse order.

5.5.11.2 Removal and refitting of battery pack front HV harness assembly (EV)

Removal procedure

NOTE

- Take note of warnings and instructions for maintenance of the HV system. For details, refer to [5.5.1 Warnings and instructions for operations related to HV electronic control system](#).

1. Turn off all electrical appliances and the start switch.

2. Disconnect the battery negative terminal. Refer to [3.1.6.1 Maintenance and inspection battery](#)

3. Remove the front lower protective plate (refer to [8.6.4.4 Removal and refitting of front lower protective plate \(EV\)](#))

4. Remove battery pack front HV harness assembly.

a. Disconnect battery pack connector.

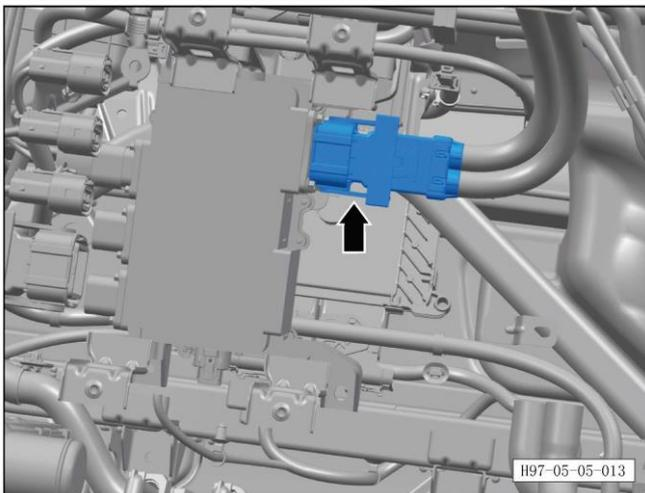

b. Unscrew 3 bolts of HV harness fixing bracket. Tightening torque of bolt: $8\pm 1\text{Nm}$.

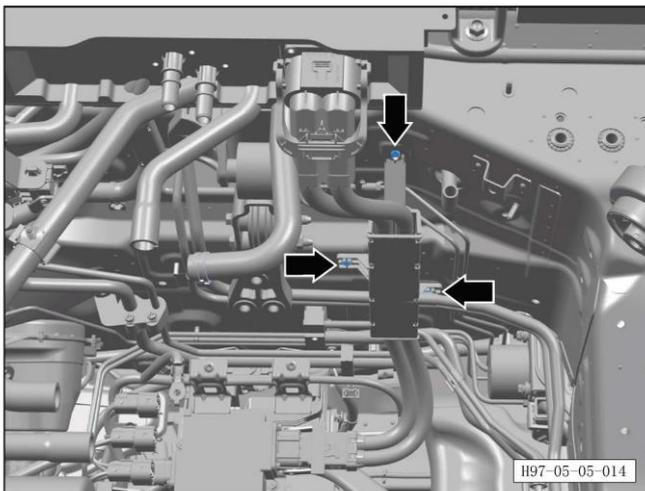

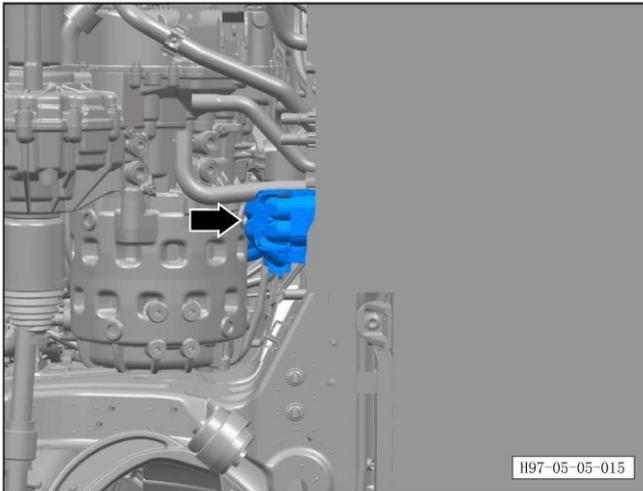

c. Disconnect the battery pack front HV harness connector.

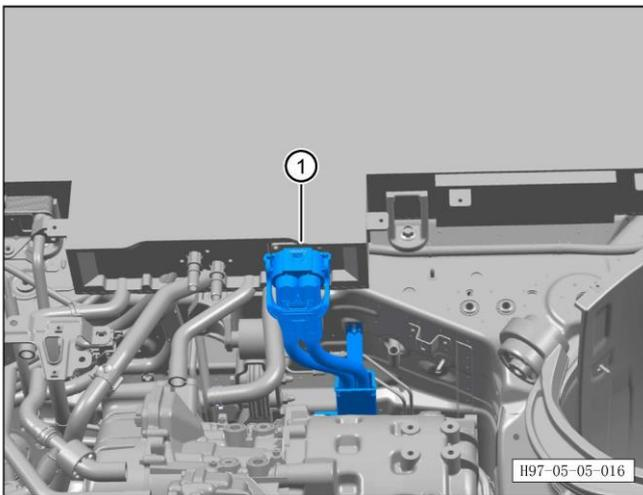

d. Remove battery pack front HV harness assembly ①.

Refitting procedure

The refitting procedure is performed in reverse order.