Contents

9.1 A/V system	9-7
9.1.1 Description and operation	9-7
9.1.2 Position diagram of parts	9-8
9.1.3 Electrical schematic diagram	9-10
9.1.4 Multimedia display	9-11
9.1.4.1 Removal and refitting of multimedia display	9-11
9.1.5 A/V unit	9-13
9.1.5.1 Removal and refitting of MP5 player assembly	9-13
9.1.6 Audio power amplifier	9-15
9.1.6.1 Removal and refitting of power amplifier	9-15
9.1.7 Speaker	9-17
9.1.7.1 Removal and refitting of instrument tweeter	9-17
9.1.7.2 Removal and refitting of rear door tweeter	9-19
9.1.7.3 Removal and refitting of front door woofer	9-21
9.1.7.4 Removal and refitting of rear door woofer	9-23
9.1.7.5 Removal and refitting of subwoofer	9-25
9.1.7.6 Removal and refitting of center speaker	9-27
9.1.8 Antenna	9-28
9.1.8.1 Removal and refitting of shark fin antenna	9-28
9.1.8.2 Removal and refitting of antenna amplifier	9-30
9.1.8.3 Removal and refitting of positive filter	9-32
9.1.8.4 Removal and refitting of negative filter	9-33
9.1.9 Microphone	9-35
9.1.9.1 Removal and refitting of microphone	9-35
9.1.9.2 Removal and refitting of single microphone	9-36
9.1.9.3 Removal and refitting of dual microphone	9-37
9.2 T-BOX	9-38
9.2.1 Description and operation	9-38
9.2.2 Position diagram of parts	9-39
9.2.3 Electrical schematic diagram	9-40
9.2.4 T-BOX	9-41
9.2.4.1 Removal and refitting of T-BOX.....	9-41
9.3 Sound signal system	9-43
9.3.1 Description and operation	9-43

9.3.2 Position diagram of parts	9-44
9.3.3 Electrical schematic diagram of horn system	9-46
9.3.4 Electrical schematic diagram of VSP	9-47
9.3.5 Horn	9-48
9.3.5.1 Removal and refitting of woofer	9-48
9.3.5.2 Removal and refitting of tweeter	9-50
9.3.6 VSP	9-52
9.3.6.1 Removal and refitting of VSP controller	9-52
9.4 LV power supply system	9-54
9.4.1 Description and operation	9-54
9.4.2 Warning and notice	9-55
9.4.3 Position diagram of parts	9-56
9.4.4 LV battery and accessories	9-58
9.4.4.1 Removal and refitting of battery (REV)	9-58
9.4.4.2 Removal and refitting of battery (EV)	9-61
9.4.4.3 Removal and refitting of battery sensor	9-64
9.4.5 Power supply 12 V interface	9-65
9.4.5.1 Removal and refitting of console 12 V power socket	9-65
9.4.5.2 Removal and refitting of trunk 12 V power socket	9-66
9.4.5.3 Removal and refitting of USB charger	9-67
9.4.6 Mobile phone wireless charging	9-68
9.4.6.1 Removal and refitting of mobile phone wireless charging controller	9-68
9.5 BCM	9-69
9.5.1 Description and operation	9-69
9.5.2 Warning and notice	9-70
9.5.3 Position diagram of parts	9-71
9.5.4 Electrical schematic diagram	9-73
9.5.5 Gateway	9-74
9.5.5.1 Removal and refitting of gateway	9-74
9.5.6 APM	9-76
9.5.6.1 Removal and refitting of APM	9-76
9.5.7 BCM	9-77
9.5.7.1 Removal and refitting of cabin central control box	9-77
9.5.7.2 Removal and refitting of cabin central control box bracket	9-79
9.5.8 Hidden handle control	9-80
9.5.8.1 Removal and refitting of left front door hidden handle control unit	9-80

9.5.9 ETC T-box	9-82
9.5.9.1 Removal and refitting of ETC	9-82
9.5.10 Rain/light sensing device	9-83
9.5.10.1 Removal and refitting of rain/light sensor	9-83
9.6 Electric control system	9-85
9.6.1 Window regulator control device	9-85
9.6.1.1 Description and operation	9-85
9.6.1.2 Position diagram of parts	9-86
9.6.1.3 Electrical schematic diagram	9-87
9.6.1.4 Removal and refitting of left front door power window switch	9-88
9.6.1.5 Removal and refitting of right front door power window switch	9-89
9.6.2 Central lock control device	9-91
9.6.2.1 Description and operation	9-91
9.6.2.2 Position diagram of parts	9-92
9.6.2.3 Electrical schematic diagram	9-93
9.6.2.4 Removal and refitting of central lock switch	9-94
9.6.3 Start/stop control device	9-95
9.6.3.1 Description and operation	9-95
9.6.3.2 Removal and refitting of engine start/stop button	9-96
9.6.4 A/C control device	9-97
9.6.4.1 Description and operation	9-97
9.6.4.2 Removal and refitting of automatic A/C control panel	9-98
9.6.5 Touch control device	9-99
9.6.5.1 Description and operation	9-99
9.6.5.2 Removal and refitting of touchpad	9-100
9.6.6 Multifunction combination control device	9-101
9.6.6.1 Description and operation	9-101
9.6.6.2 Removal and refitting of console combination switch	9-105
9.6.6.3 Removal and refitting of steering column switch assembly	9-106
9.6.6.4 Removal and refitting of clock spring	9-107
9.6.6.5 Removal and refitting of lamp switch	9-109
9.6.7 Tailgate opening/closing control device	9-110
9.6.7.1 Description and operation	9-110
9.6.7.2 Position diagram of parts	9-111
9.6.7.3 Removal and refitting of POT opening/closing switch	9-113
9.6.7.4 Removal and refitting of POT closing switch	9-114

9.6.7.5 Removal and refitting of trunk lid opening switch	9-114
9.6.7.6 Removal and refitting of POT controller	9-116
9.6.8 EPB control device	9-118
9.6.8.1 Description and operation	9-118
9.6.8.2 Position diagram of parts	9-119
9.6.8.3 Removal and refitting of EPB switch	9-120
9.7 PEPS	9-121
9.7.1 Description and operation	9-121
9.7.2 Position diagram of parts	9-122
9.7.3 PEPS antenna	9-124
9.7.3.1 Removal and refitting of front door PEPS antenna	9-124
9.7.4 Smart remote key	9-125
9.7.4.1 Removal and refitting of smart remote key battery	9-125
9.7.5 Digital key Bluetooth module	9-126
9.7.5.1 Removal and refitting of low power consumption Bluetooth main module	9-126
9.7.5.2 Removal and refitting of front door low power consumption Bluetooth auxiliary module	9-127
9.7.5.3 Removal and refitting of rear bumper low power consumption Bluetooth auxiliary module	9-129
9.7.6 Kick opening/closing sensing device	9-131
9.7.6.1 Removal and refitting of kick controller	9-131
9.7.6.2 Removal and refitting of kick sensor strip	9-133
9.8 Driving monitoring and driving signal indication system	9-134
9.8.1 Description and operation	9-134
9.8.2 Position diagram of parts	9-135
9.8.3 TPMS	9-137
9.8.3.1 Removal and refitting of tire pressure sensor	9-137
9.8.4 DVR	9-138
9.8.4.1 Removal and refitting of DVR camera	9-138
9.8.4.2 Removal and refitting of memory card module assembly	9-138
9.8.5 DMS camera	9-140
9.8.5.1 Removal and refitting of in-vehicle camera controller	9-140
9.8.5.2 Removal and refitting of DMS camera	9-142
9.8.5.3 Removal and refitting of OMS camera	9-143
9.8.6 Night vision	9-144
9.8.6.1 Removal and refitting of NVS camera	9-144
9.8.6.2 Removal and refitting of NVS control unit	9-145
9.8.6.3 Removal and refitting of NVS fill lamp	9-147

9.9 Lighting signal system	9-149
9.9.1 Description and operation	9-149
9.9.2 Position diagram of parts	9-151
9.9.3 Headlamp	9-153
9.9.3.1 Removal and refitting of headlamp	9-153
9.9.3.2 Removal and refitting of front position lamp	9-155
9.9.4 Rear combination lamp	9-157
9.9.4.1 Removal and refitting of rear combination lamp fixed side	9-157
9.9.4.2 Removal and refitting of rear combination lamp fixed side plate.....	9-159
9.9.4.3 Removal and refitting of rear combination lamp movable side plate.....	9-160
9.9.4.4 Removal and refitting of rear combination lamp movable side	9-161
9.9.5 3rd brake lamp (high-mounted brake lamp)	9-163
9.9.5.1 Removal and refitting of 3rd brake lamp	9-163
9.9.6 License plate lamp	9-165
9.9.6.1 Removal and refitting of license plate lamp	9-165
9.9.7 Rear fog lamp and side turn signal lamp	9-167
9.9.7.1 Removal and refitting of rear fog lamp	9-167
9.9.7.2 Removal and refitting of side turn signal lamp	9-169
9.9.8 Ambient lamp	9-171
9.9.8.1 Removal and refitting of door handle ambient lamp	9-171
9.9.8.2 Removal and refitting of IP ambient lamp control module	9-173
9.9.8.3 Removal and refitting of door ambient lamp control module	9-175
9.9.8.4 Removal and refitting of point light source	9-177
9.9.8.5 Removal and refitting of stepless dimming glass controller	9-178
9.9.9 Front door floor lamp	9-180
9.9.9.1 Removal and refitting of front door floor lamp	9-180
9.9.10 External charging indicator	9-181
9.9.10.1 Removal and refitting of charging indicator	9-181
9.9.11 Interior lamp	9-183
9.9.11.1 Removal and refitting of trunk lamp	9-183
9.9.11.2 Removal and refitting of front ceiling lamp assembly	9-184
9.9.11.3 Removal and refitting of rear ceiling lamp assembly	9-186
9.10 Intelligent driving system	9-188
9.10.1 Description and operation	9-188
9.10.2 Position diagram of parts	9-190
9.10.3 Advanced driving and parking assist	9-192

9.10.3.1 Removal and refitting of MMW radar mounting bracket	9-192
9.10.3.2 Removal and refitting of MMW radar trim cover assembly	9-194
9.10.3.3 Removal and refitting of forward MMW radar	9-195
9.10.3.4 Removal and refitting of rear corner radar	9-196
9.10.3.5 Removal and refitting of RPA sensor	9-198
9.10.3.6 Removal and refitting of parking radar sensor	9-199
9.10.3.7 Removal and refitting of RPA controller.....	9-200
9.10.3.8 Removal and refitting of APA ECU	9-202
9.10.4 Image assist	9-204
9.10.4.1 Removal and refitting of FVC assembly	9-204
9.10.4.2 Removal and refitting of FVC trim panel	9-205
9.10.4.3 Removal and refitting of RVC assembly	9-207
9.10.4.4 Removal and refitting of AVM assembly	9-209
9.10.4.5 Removal and refitting of front view monocular camera	9-211

9.1 A/V system

9.1.1 Description and operation

MP5 player - A/V system

This system is a 12.3-inch full LCD screen with a screen ratio of 16:9 and a resolution of 1,920*720. The host is of a I.MAX8QM hardware architecture using Android and LINUX operating systems for the display and reminders of vehicle-related information.

This system consists of MP5 player, IVI display, front passenger display, instrument display, two front door woofers, two rear door woofers, two instrument tweeters, instrument center speaker, subwoofer, power amplifier, shark fin antenna (AM/FM) and microphone, which have powerful audio and video entertainment and driving assistance functions, including: radio, U disk, Bluetooth adapter (match with the Bluetooth mobile phone to achieve hands-free answer), driving assistance settings, A/C control display and mobile phone interconnection functions.

9.1.2 Position diagram of parts

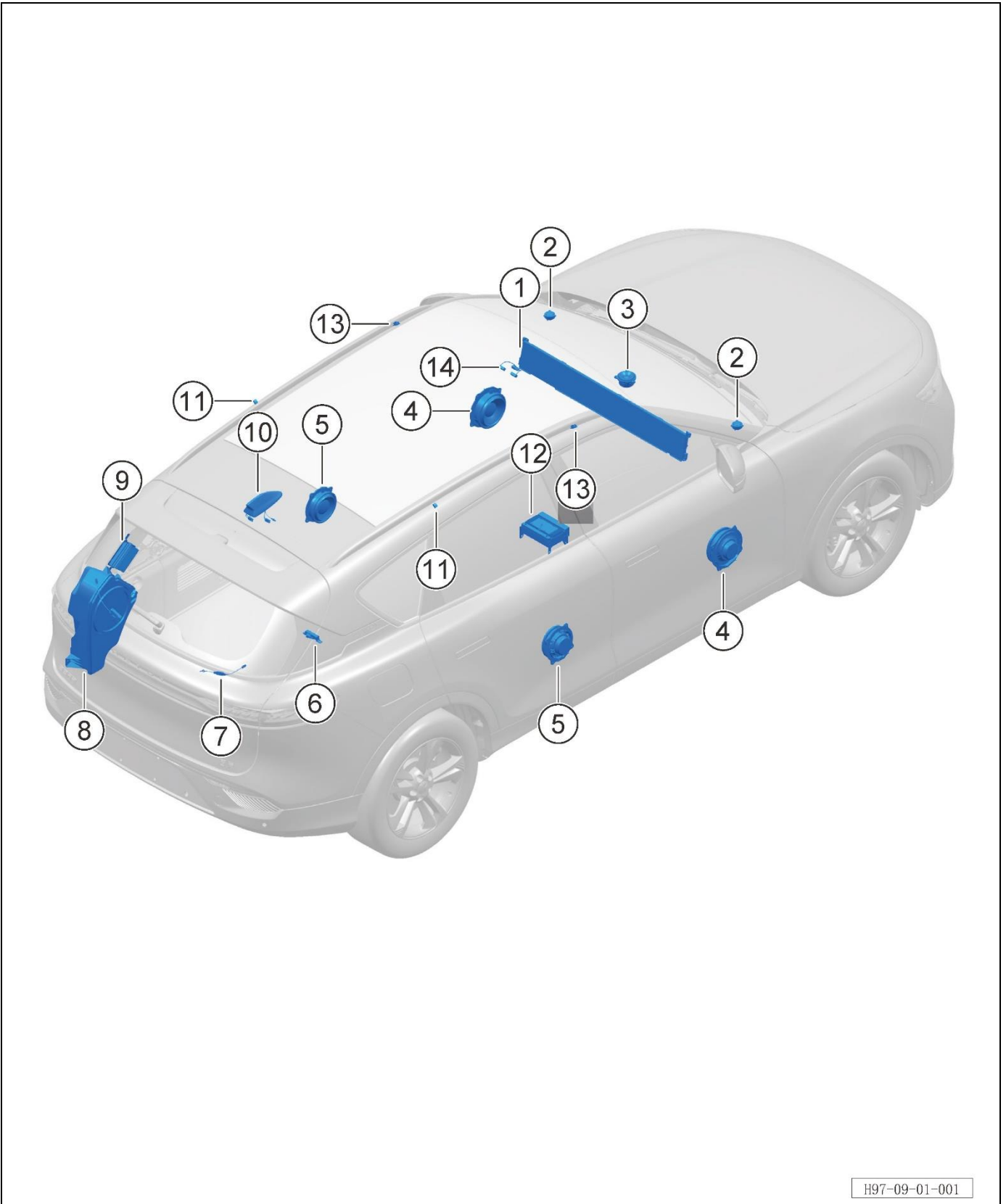

S/N	Part name	Loading quantity	Remarks
1	Multimedia display	1	
2	Loudspeaker	2	
3	Center speaker	1	
4	Front door woofer	2	
5	Rear door woofer	2	
6	Rear PS antenna	1	
7	Negative filter	1	
8	Subwoofer	1	
9	Power amplifier	1	
10	Shark fin	1	
11	Microphone	2	
12	MP5 player	1	
13	Single microphone	2	
14	Dual microphone	1	

9.1.3 Electrical schematic diagram

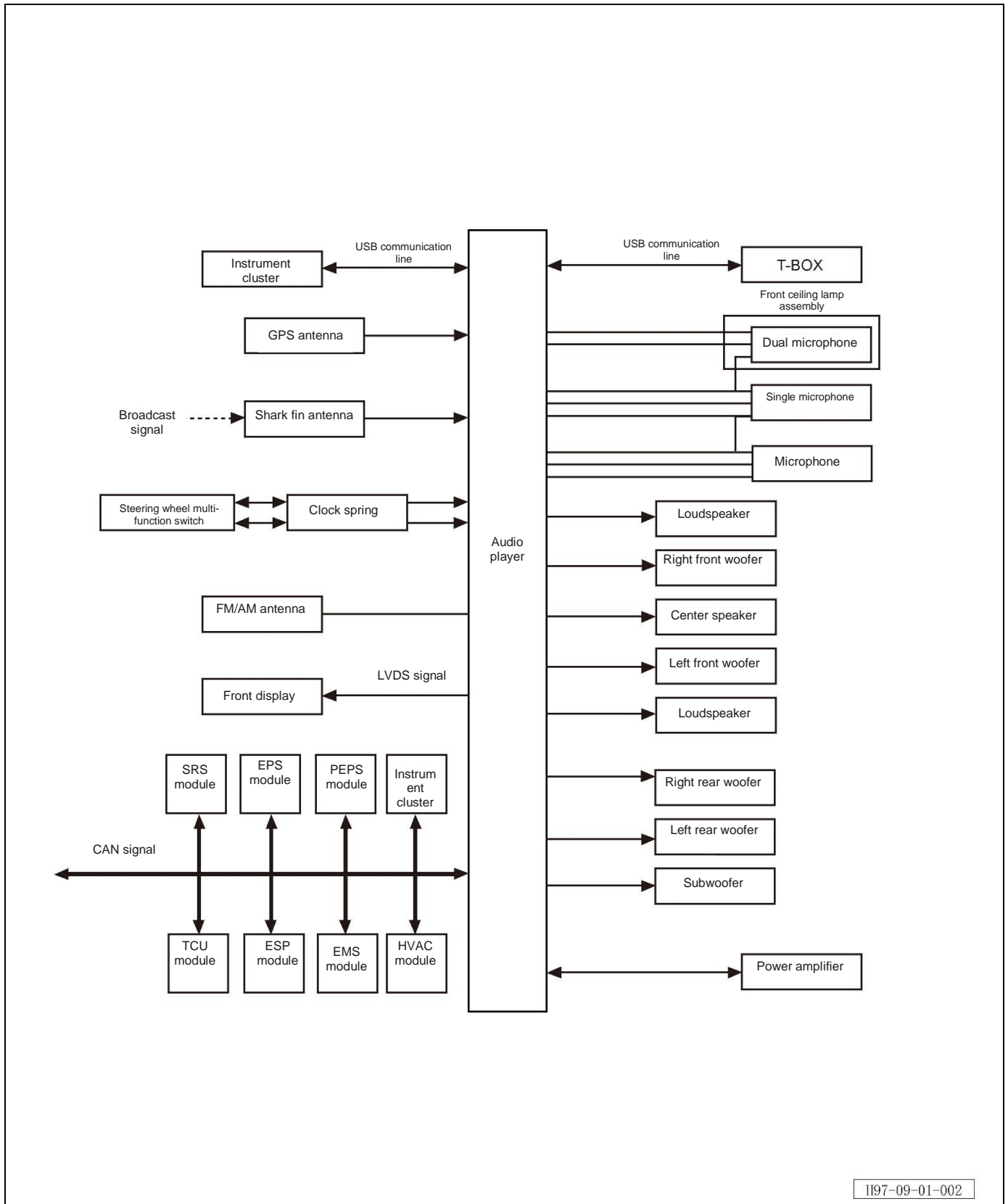

II97-09-01-002

9.1.4 Multimedia display

9.1.4.1 Removal and refitting of multimedia display

Removal procedure

1. Turn off all electrical appliances and the start switch.
2. Disconnect the negative terminal of the battery (refer to [3.1.7.1 Maintenance and inspection of battery](#))
3. Remove the screen upper cover plate frame assembly (refer to [8.2.4.22 Removal and refitting of screen upper cover plate frame assembly](#))
4. Remove the right trim panel assembly (refer to [8.2.4.19 Removing and refitting of right trim panel assembly](#))
5. Remove the left trim panel assembly (refer to [8.2.4.18 Removal and refitting of left trim panel assembly](#))
6. Remove the side air outlet assembly (refer to [8.2.4.10 Removal and refitting of side air outlet assembly](#))
7. Remove the multimedia display.

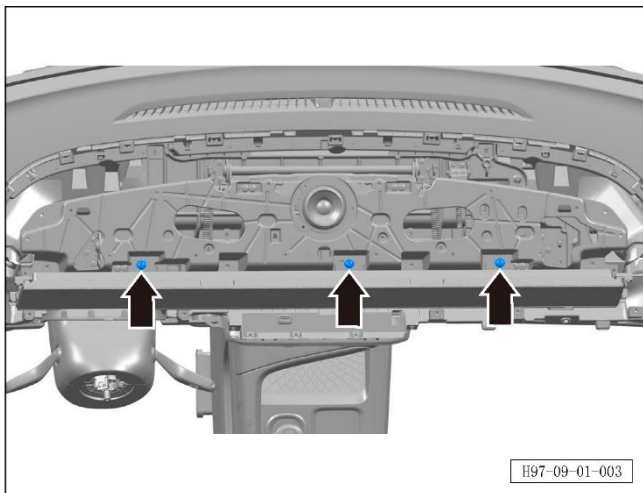

H97-09-01-003

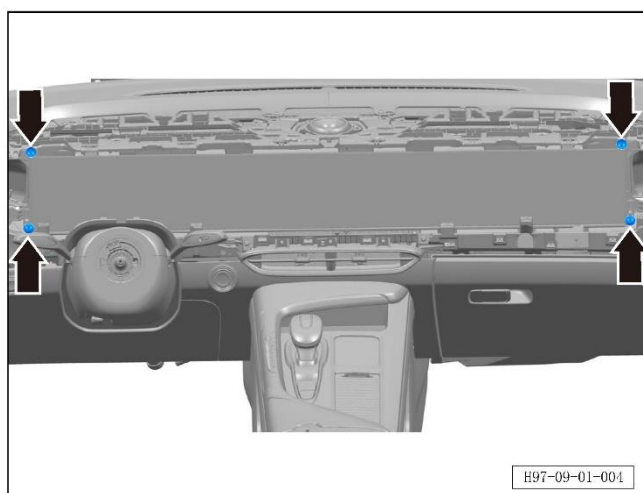

H97-09-01-004

- a. Unscrew 3 fixing bolts on the upper part of the multimedia display.

Tightening torque of bolt: $6\pm 1\text{Nm}$.

- b. Unscrew 4 fixing bolts on the left and right sides of the multimedia display.

Tightening torque of bolt: $6\pm 1\text{Nm}$.

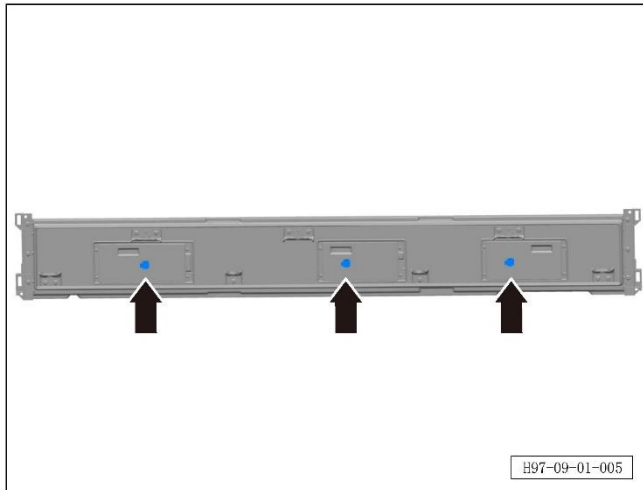

c. Disconnect the connector of the multimedia display.

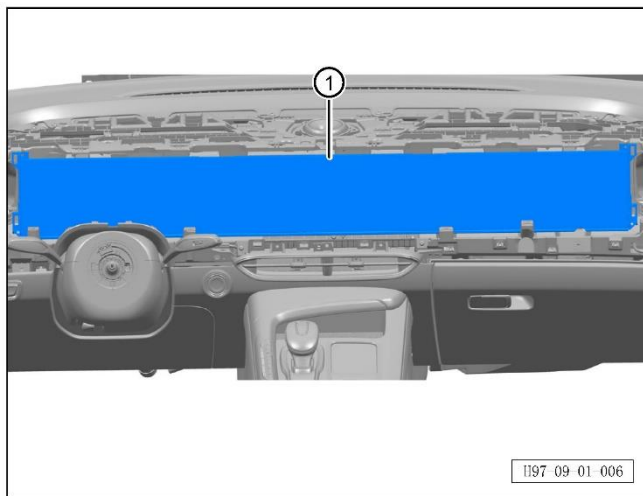

d. Remove the multimedia display ①.

Refitting procedure

The refitting procedure is performed in reverse order.

9.1.5 A/V unit

9.1.5.1 Removal and refitting of MP5 player assembly

Removal procedure

1. Turn off all electrical appliances and the start switch.
2. Disconnect the negative terminal of the battery (refer to [3.1.7.1 Maintenance and inspection of battery](#))
3. Remove the console assembly (refer to [8.3.4.22 Removal and refitting of console assembly](#))
4. Remove the MP5 player assembly.

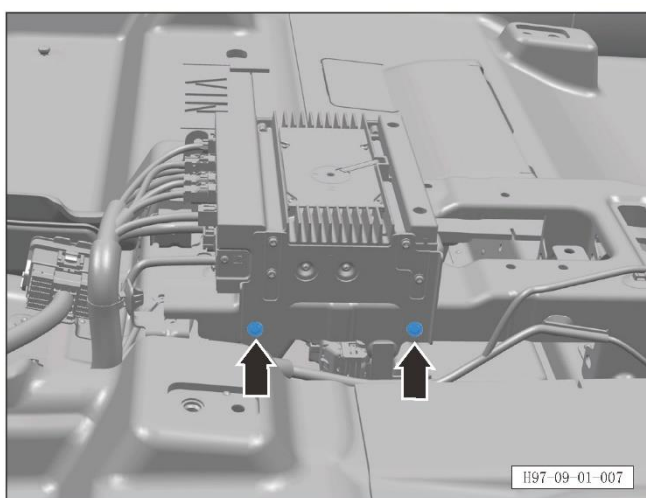

a. Unscrew 2 fixing bolts at the left side of the MP5 player assembly.

Tightening torque of bolt: $8\pm 1\text{Nm}$.

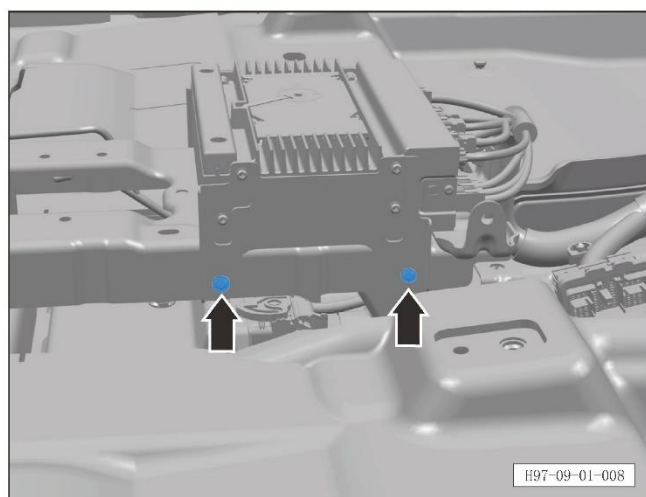

b. Unscrew 2 fixing bolts at the right side of the MP5 player assembly.

Tightening torque of bolt: $8\pm 1\text{Nm}$.

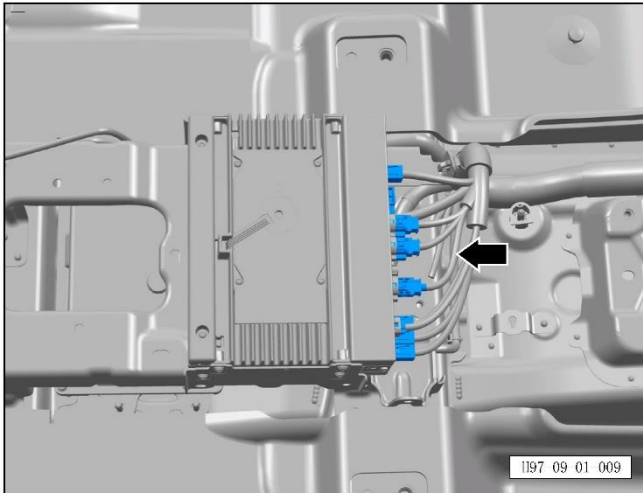

c. Disconnect all connectors of the MP5 player assembly.

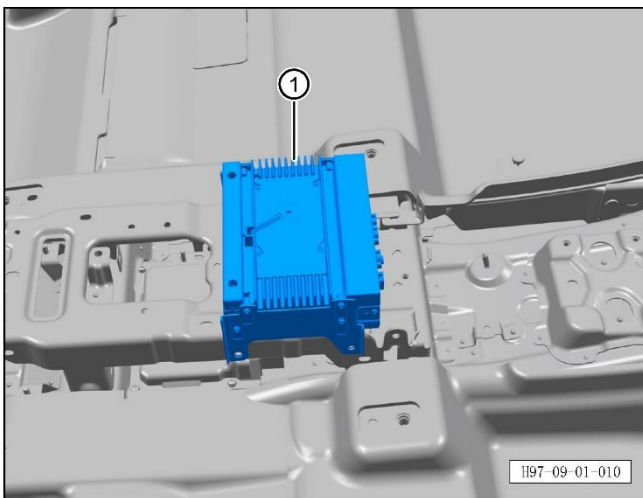

d. Remove the MP5 player assembly ①.

Refitting procedure

The refitting procedure is performed in reverse order.

9.1.6 Audio power amplifier

9.1.6.1 Removal and refitting of power amplifier

Removal procedure

1. Turn off all electrical appliances and the start switch.
2. Disconnect the negative terminal of the battery (refer to [3.1.7.1 Maintenance and inspection of battery](#))
3. Remove the left rear side wall panel inner trim panel assembly (refer to [8.5.5.10 Removal and refitting of rear side wall panel inner trim panel](#))
4. Remove the power amplifier.

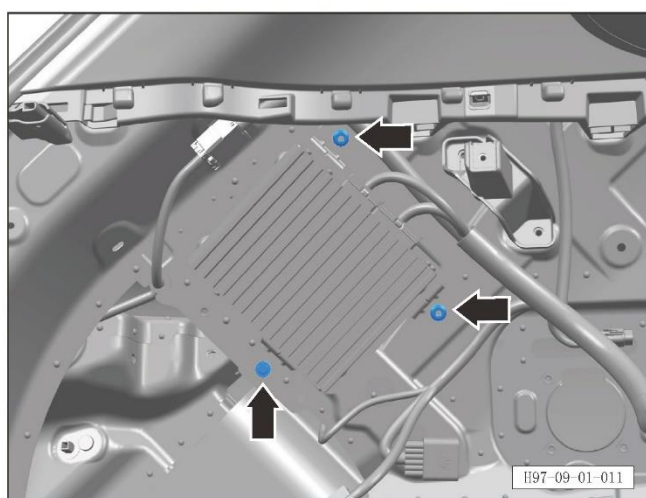

- a. Unscrew 1 fixing bolt and 2 fixing nuts of the power amplifier.

Tightening torque of bolt: $8\pm 1\text{Nm}$.

Tightening torque of nut: $8\pm 1\text{Nm}$.

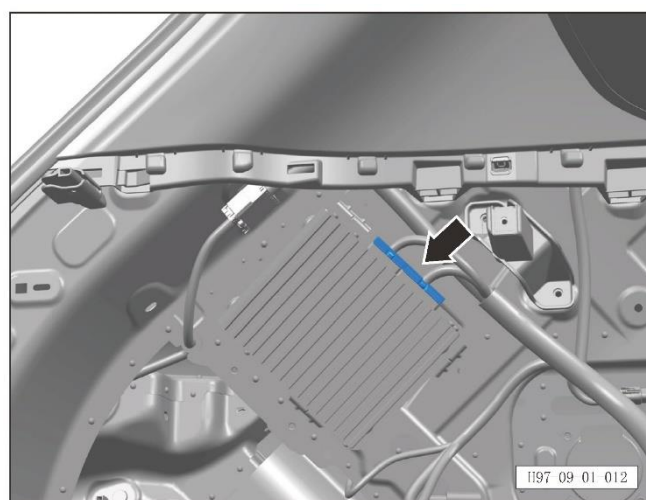

- b. Disconnect 2 connectors of the power amplifier.

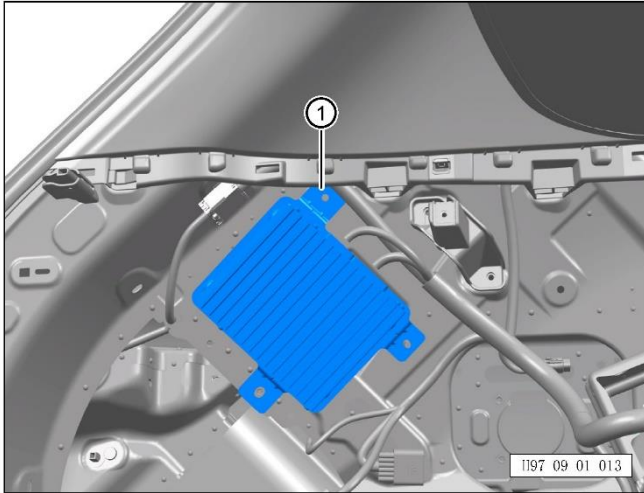

c. Remove the power amplifier ①.

Refitting procedure

The refitting procedure is performed in reverse order.

9.1.7 Speaker

9.1.7.1 Removal and refitting of instrument tweeter

Removal procedure

Note:

- The following is the removal and refitting of the instrument panel left tweeter, which can be referred to for the operations on the right side.

1. Turn off all electrical appliances and the start switch.

2. Disconnect the negative terminal of the battery (refer to [3.1.7.1 Maintenance and inspection of battery](#))

3. Remove the left tweeter cover assembly (refer to [8.2.4.17 Removal and refitting of left tweeter cover assembly](#))

4. Remove the instrument left tweeter.

a. Unscrew 3 fixing screws of the instrument left tweeter.

Tightening torque of screws: (2 ± 1) Nm.

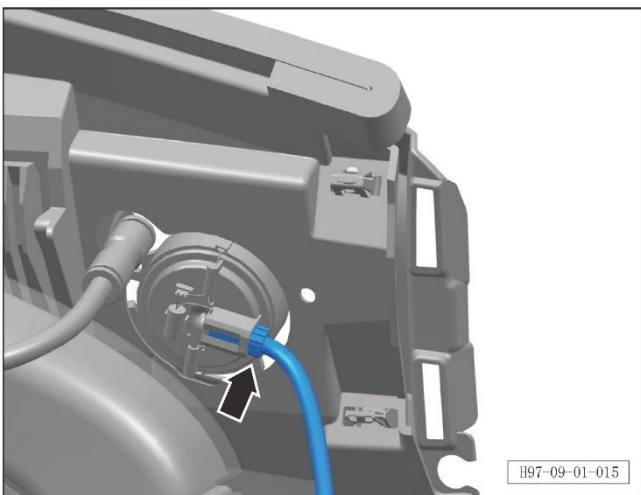
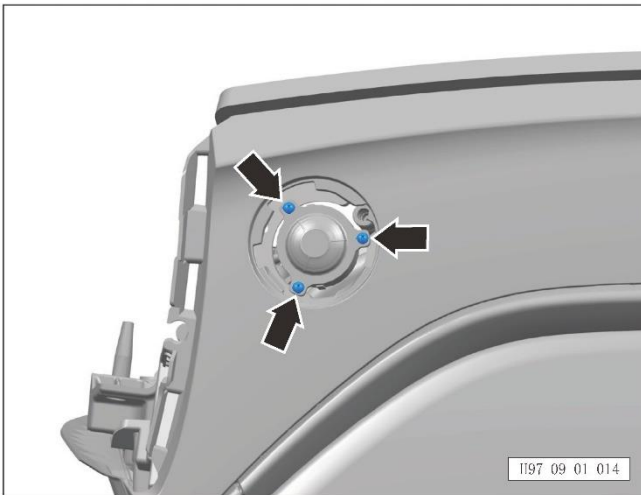

b. Disconnect the connector of the instrument left tweeter.

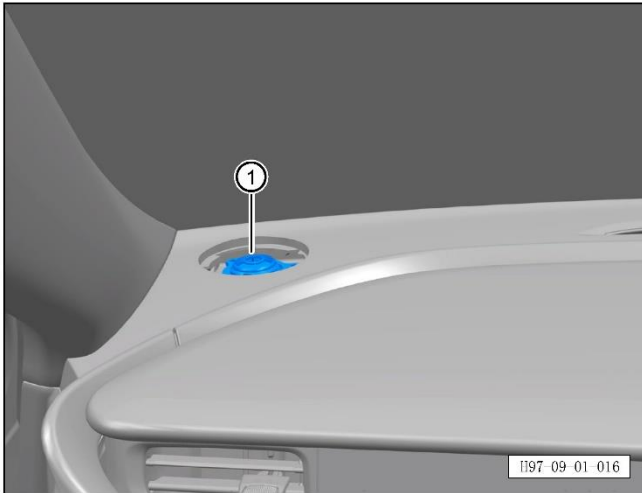

c. Remove the instrument left tweeter ①.

Refitting procedure

The refitting procedure is performed in reverse order.

9.1.7.2 Removal and refitting of rear door tweeter

Removal procedure

Note:

- The following is the removal and refitting of the left rear door tweeter, which can be referred to for the operations on the right side.

1. Turn off all electrical appliances and the start switch.
2. Disconnect the negative terminal of the battery (refer to [3.1.7.1 Maintenance and inspection of battery](#))
3. Remove the left rear door trim panel assembly (refer to [8.4.3.1 Removal and refitting of rear door trim panel assembly](#))
4. Remove the left rear door tweeter.

a. Disconnect the connector of the left rear door tweeter.

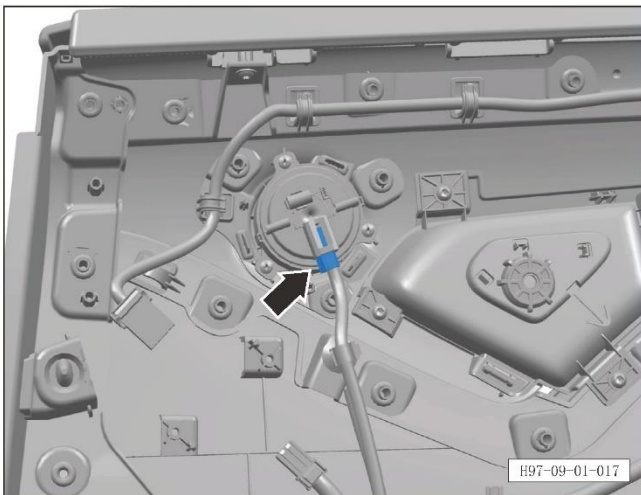

b. Unscrew 3 fixing screws of the left rear door tweeter.

Tightening torque of screw: $2\pm 1\text{Nm}$

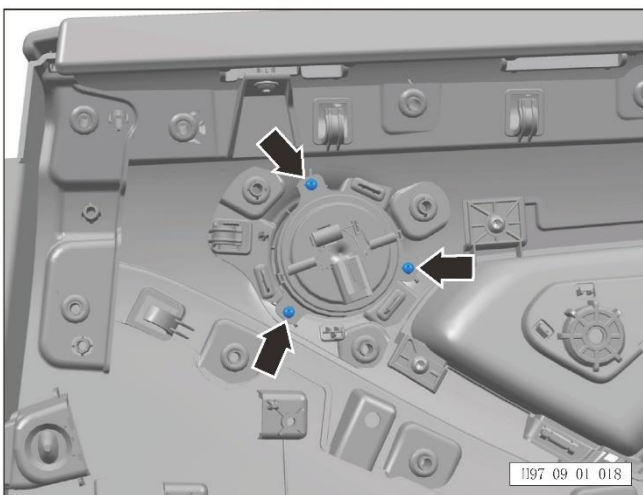

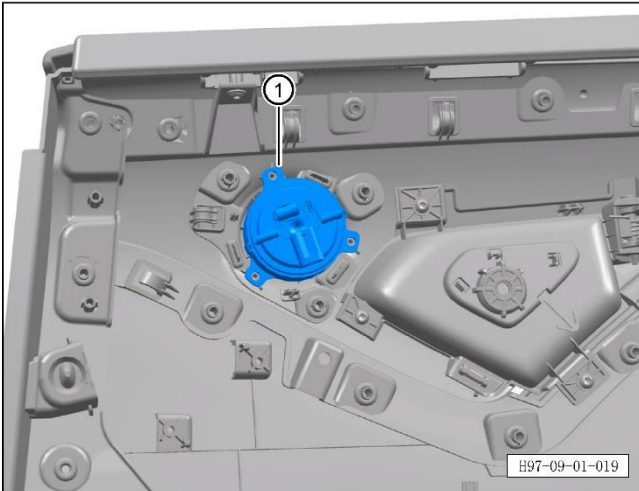

c. Remove the left rear door tweeter ①.

Refitting procedure

The refitting procedure is performed in reverse order.

9.1.7.3 Removal and refitting of front door woofer

Removal procedure

Note:

- The following is the removal and refitting of the left front door woofer, which can be referred to for the operations on the right side.

1. Turn off all electrical appliances and the start switch.
2. Disconnect the negative terminal of the battery (refer to [3.1.7.1 Maintenance and inspection of battery](#))
3. Remove the left front door trim panel assembly (refer to [8.4.2.1 Removal and refitting of front door trim panel assembly](#))
4. Remove the left front door woofer.

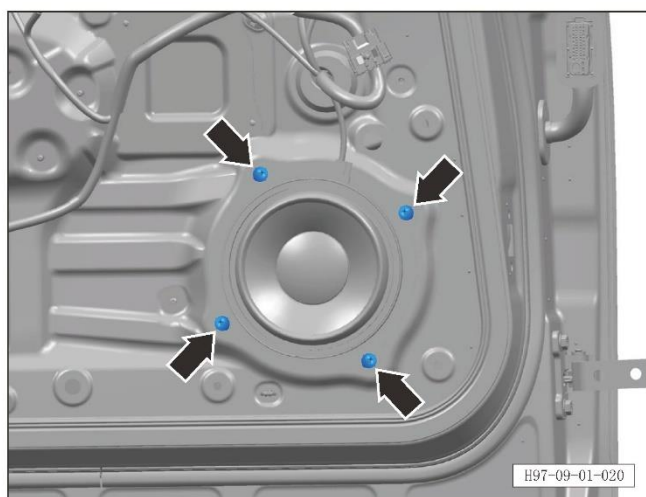

- a. Unscrew 4 fixing screws of the left front door woofer.

Tightening torque of screw: $2\pm 1\text{Nm}$

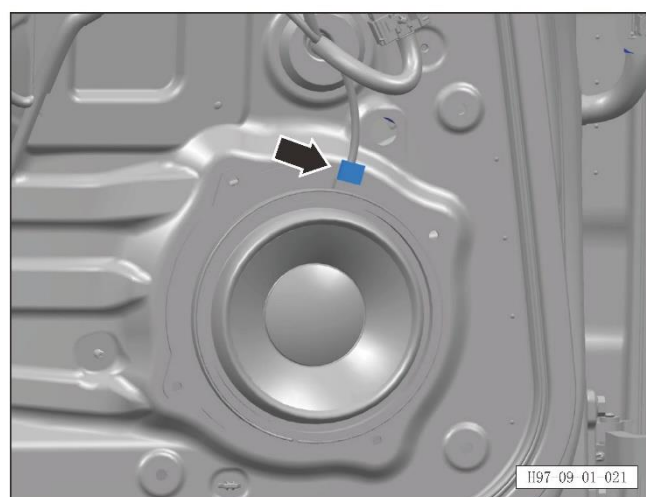

- b. Disconnect the connector of the left front door woofer.

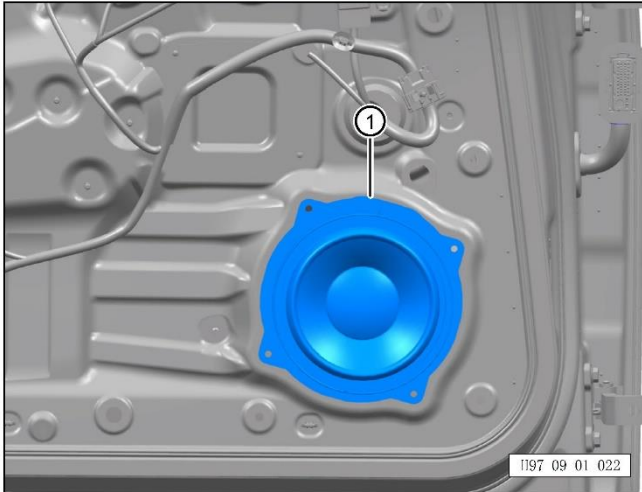

c. Remove the left front door woofer ①.

Refitting procedure

The refitting procedure is performed in reverse order.

9.1.7.4 Removal and refitting of rear door woofer

Removal procedure

Note:

- The following is the removal and refitting of the left rear door woofer, which can be referred to for the operations on the right side.

1. Turn off all electrical appliances and the start switch.

2. Disconnect the negative terminal of the battery (refer to [3.1.7.1 Maintenance and inspection of battery](#))

3. Remove the left rear door trim panel assembly (refer to [8.4.3.1 Removal and refitting of rear door trim panel assembly](#))

4. Remove the left rear door woofer.

a. Unscrew 4 fixing screws of the left rear door woofer.

Tightening torque of screw: $2\pm 1\text{Nm}$

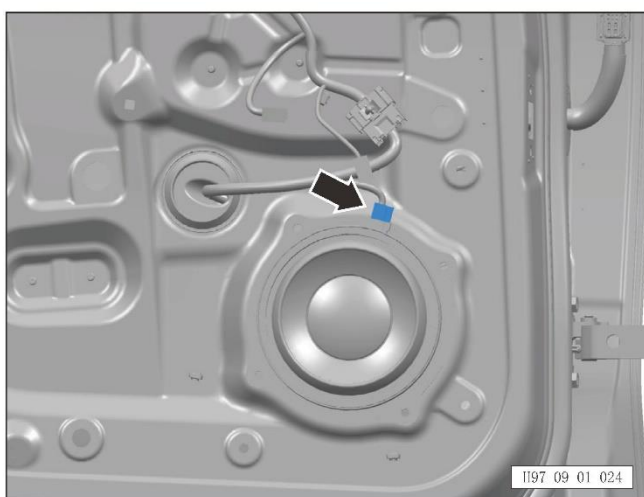
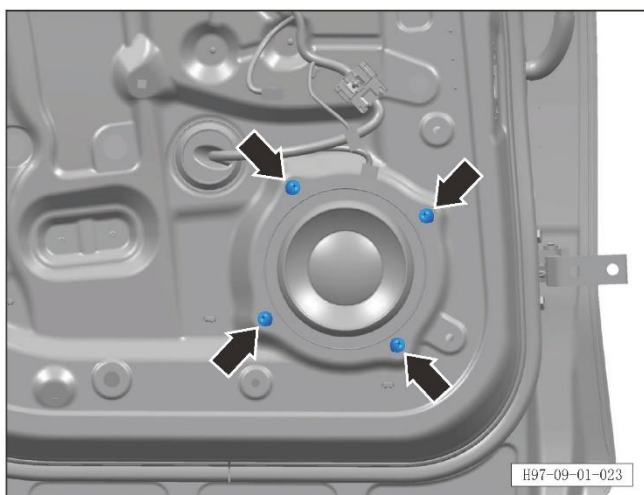

b. Disconnect the connector of the left rear door woofer.

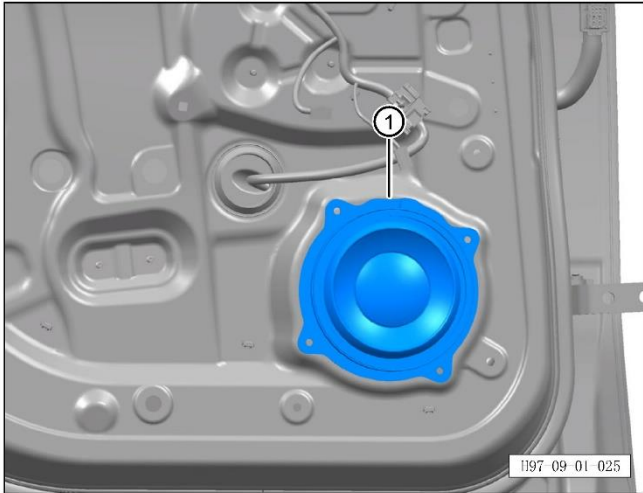

c. Remove the left rear door woofer ①.

Refitting procedure

The refitting procedure is performed in reverse order.

9.1.7.5 Removal and refitting of subwoofer

Removal procedure

1. Turn off all electrical appliances and the start switch.
2. Disconnect the negative terminal of the battery (refer to [3.1.7.1 Maintenance and inspection of battery](#))
3. Remove the left rear side wall panel inner trim panel assembly (refer to [8.5.5.10 Removal and refitting of rear side wall panel inner trim panel](#))
4. Remove the left rear side wall lower mounting bracket (refer to [8.5.5.19 Removal and refitting of rear side wall lower mounting bracket](#))
5. Remove the subwoofer.

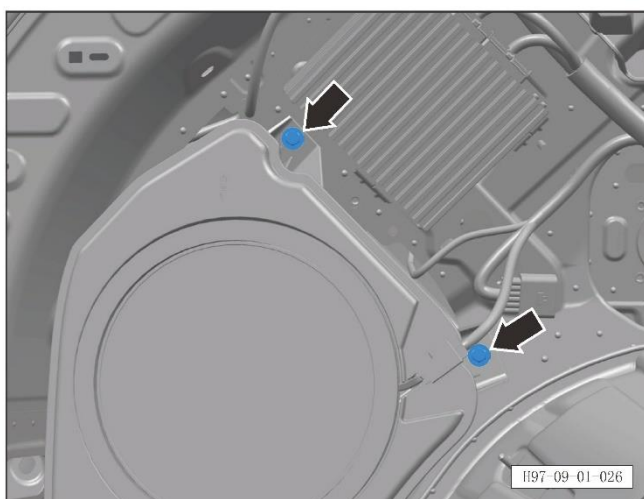

- a. Unscrew 2 fixing bolts on the upper part of the subwoofer.

Tightening torque of bolt: $8\pm 1\text{Nm}$.

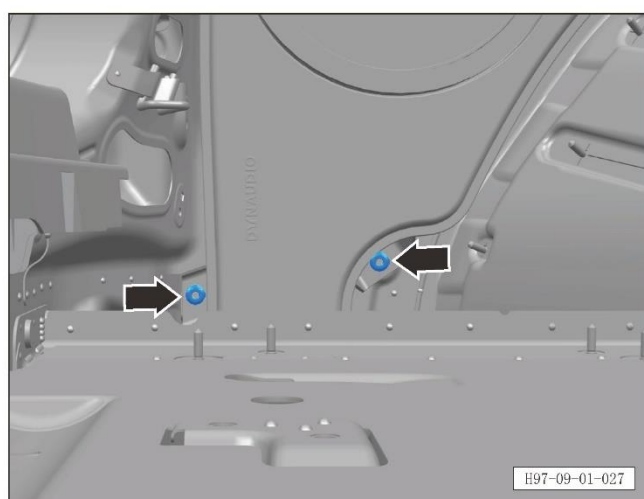

- b. Unscrew 2 fixing nuts on the lower part of the subwoofer.

Tightening torque of nut: $8\pm 1\text{Nm}$.

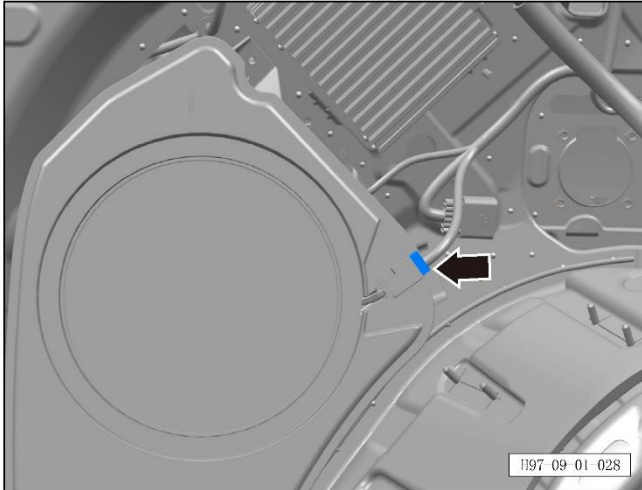

c. Disconnect the connector of the subwoofer.

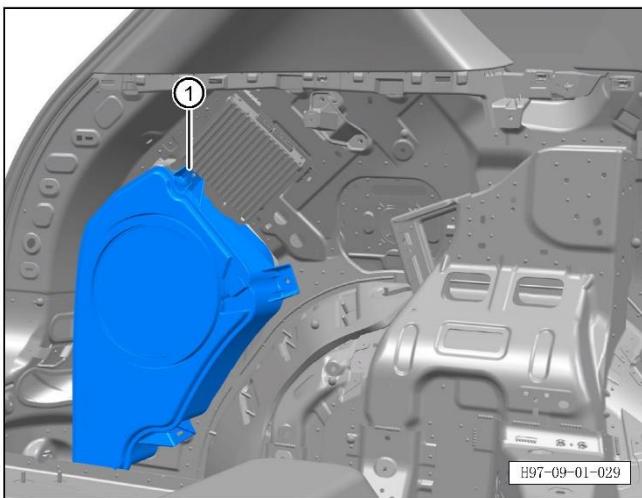

d. Remove the subwoofer ①.

Refitting procedure

The refitting procedure is performed in reverse order.

9.1.7.6 Removal and refitting of center speaker

Removal procedure

1. Turn off all electrical appliances and the start switch.
2. Disconnect the negative terminal of the battery (refer to [3.1.7.1 Maintenance and inspection of battery](#))
3. Remove the screen upper cover plate body (refer to [8.2.4.9 Removal and refitting of screen upper cover plate body](#))
4. Remove the center speaker.

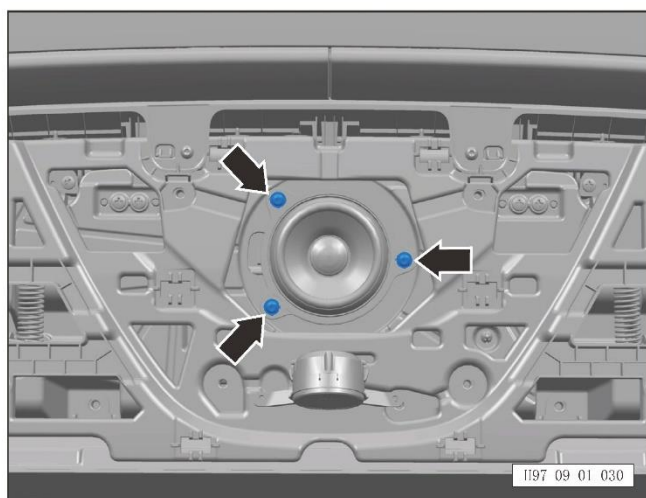

- a. Unscrew 3 fixing screws of the center speaker.

Tightening torque of screw: $2\pm 1\text{Nm}$

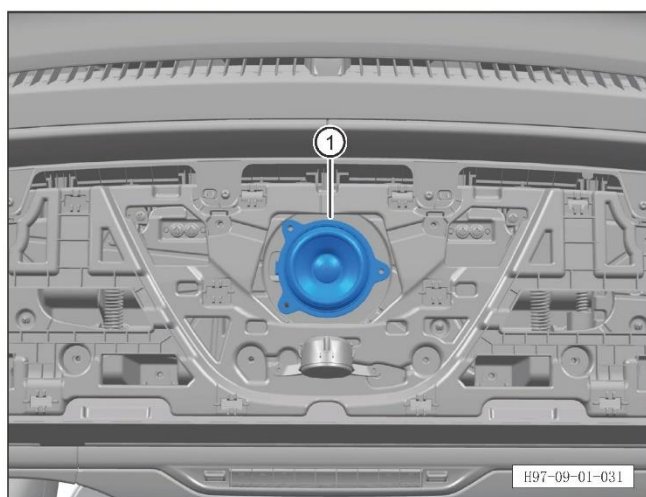

- b. Disconnect the connector of the center speaker to remove the center speaker ①.

Refitting procedure

The refitting procedure is performed in reverse order.

9.1.8 Antenna

9.1.8.1 Removal and refitting of shark fin antenna

Removal procedure

1. Turn off all electrical appliances and the start switch.
2. Disconnect the negative terminal of the battery (refer to [3.1.7.1 Maintenance and inspection of battery](#))
3. Remove the roof inner trim panel assembly (refer to [8.5.6.1 Removal and refitting of roof inner trim panel assembly](#))
4. Remove the shark fin antenna.
 - a. Unscrew 1 fixing bolt of the shark fin antenna.
Tightening torque of bolt: $6\pm 1\text{Nm}$.

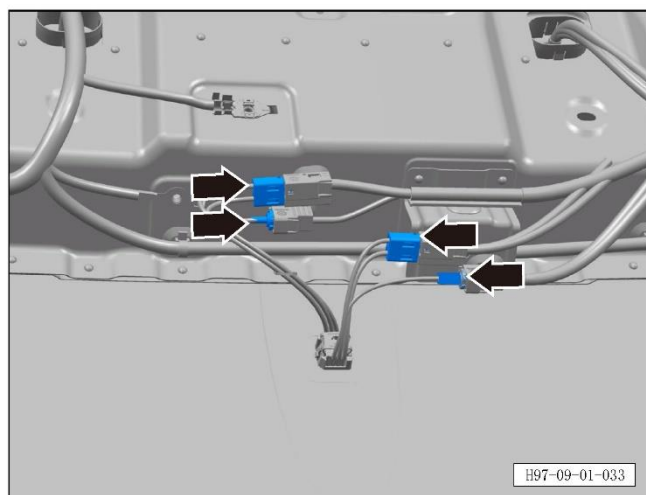
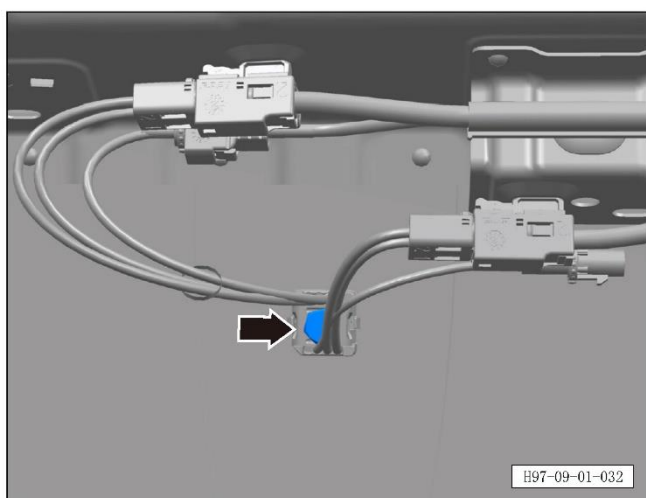

- b. Disconnect 4 connectors of the shark fin antenna.

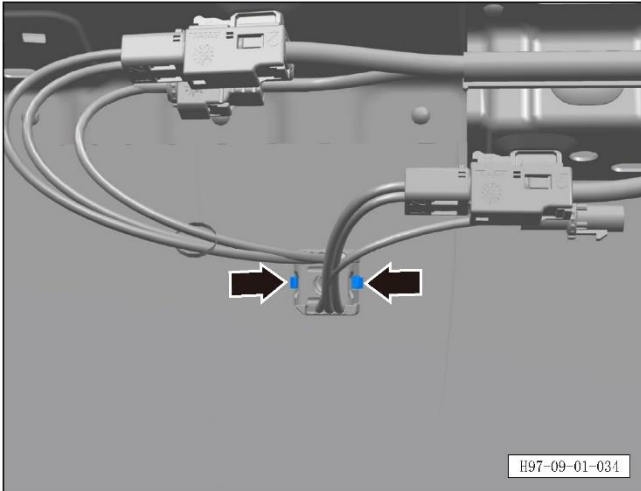

c. Disengage 2 fixing clips of the shark fin antenna.

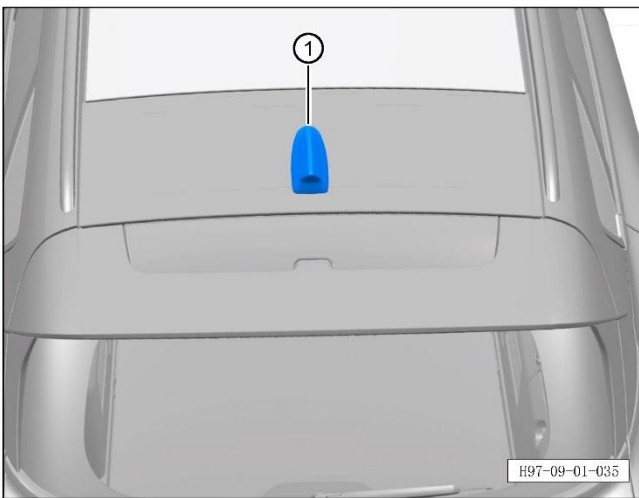

d. Remove the shark fin antenna ①.

Refitting procedure

The refitting procedure is performed in reverse order.

9.1.8.2 Removal and refitting of antenna amplifier

Removal procedure

1. Turn off all electrical appliances and the start switch.
2. Disconnect the negative terminal of the battery (refer to [3.1.7.1 Maintenance and inspection of battery](#))
3. Remove the tailgate upper panel assembly (refer to [8.4.4.1 Removal and refitting of tailgate upper panel assembly](#))
4. Remove the antenna amplifier.

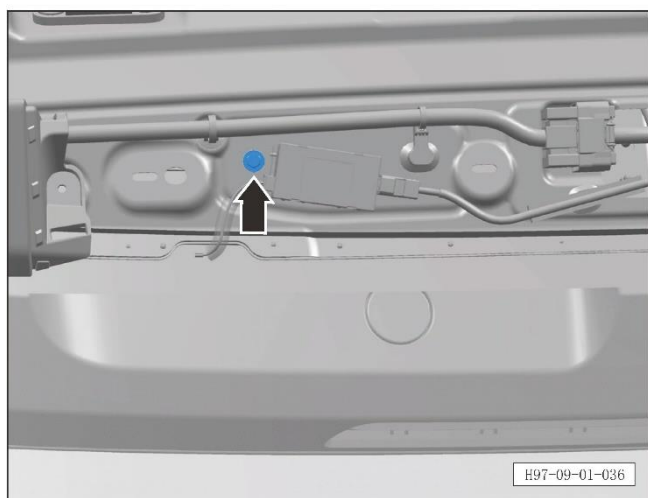

- a. Unscrew 1 fixing bolt of the antenna amplifier.
Tightening torque of bolt: $14\pm 2\text{Nm}$.

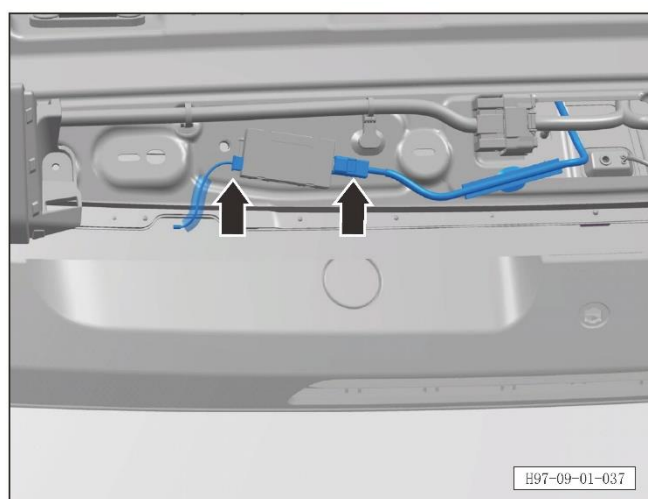

- b. Disconnect 2 connectors of the antenna amplifier.

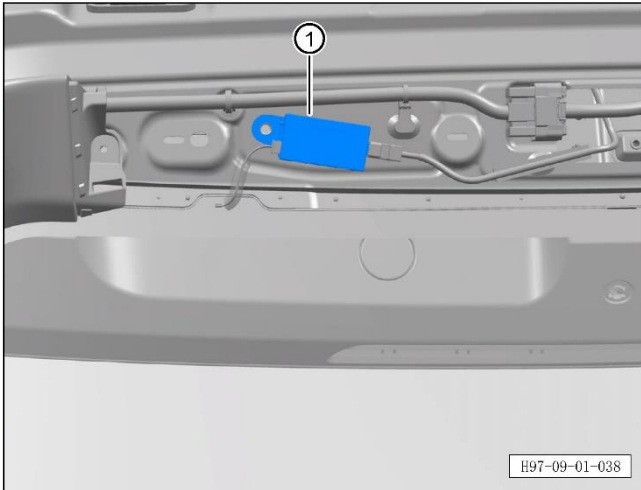

c. Remove the antenna amplifier ①.

Refitting procedure

The refitting procedure is performed in reverse order.

9.1.8.3 Removal and refitting of positive filter

Removal procedure

1. Turn off all electrical appliances and the start switch.
2. Disconnect the negative terminal of the battery (refer to [3.1.7.1 Maintenance and inspection of battery](#))
3. Remove the tailgate lower trim panel assembly (refer to [8.4.4.4 Removal and refitting of tailgate lower trim panel assembly](#))
4. Remove the tailgate left/right trim panel assembly (refer to [8.4.4.6 Removal and refitting of tailgate side trim panel assembly](#))
5. Remove the positive filter.

a. Unscrew 1 fixing bolt of the positive filter.

Tightening torque of bolt: $14\pm 2\text{Nm}$.

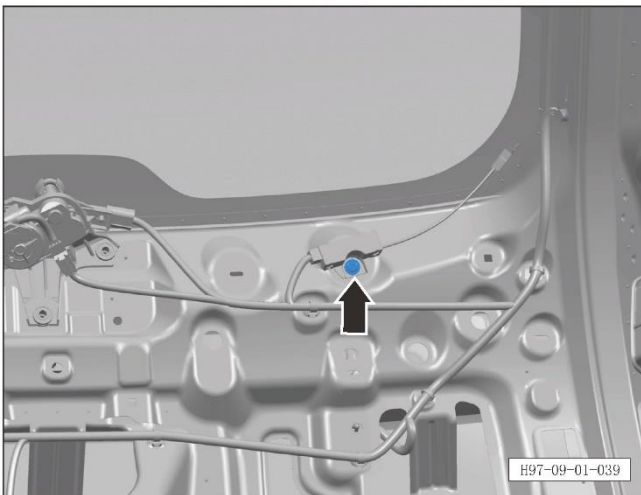

b. Disconnect 2 connectors of the positive filter.

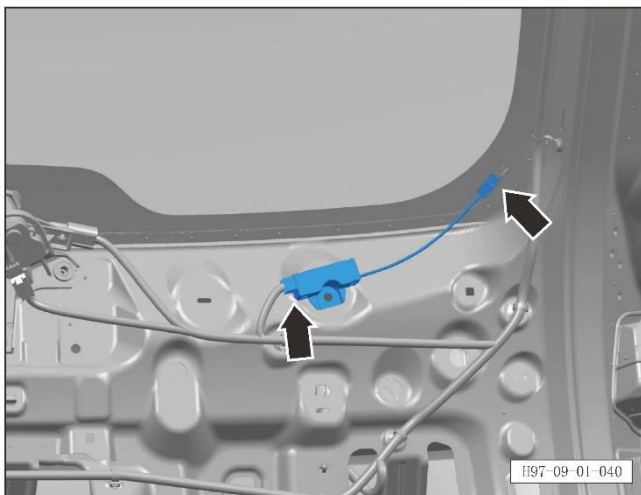

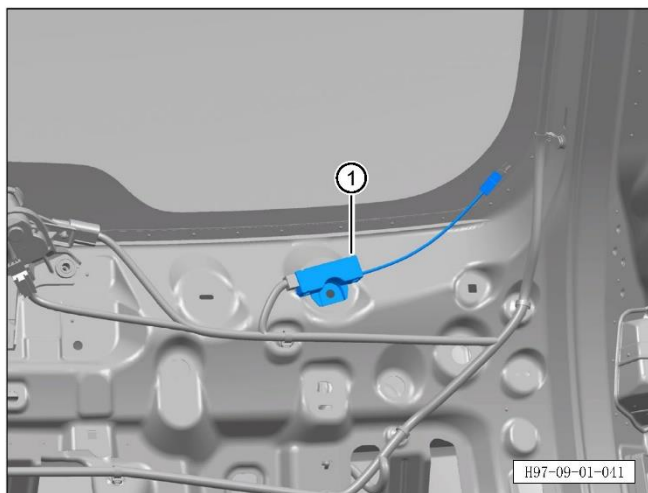

c. Remove the positive filter ①.

Refitting procedure

The refitting procedure is performed in reverse order.

9.1.8.4 Removal and refitting of negative filter

Removal procedure

1. Turn off all electrical appliances and the start switch.
2. Disconnect the negative terminal of the battery (refer to [3.1.7.1 Maintenance and inspection of battery](#))
3. Remove the tailgate lower trim panel assembly (refer to [8.4.4.4 Removal and refitting of tailgate lower trim panel assembly](#))
4. Remove the tailgate left/right trim panel assembly (refer to [8.4.4.6 Removal and refitting of tailgate side trim panel assembly](#))
5. Remove the negative filter.

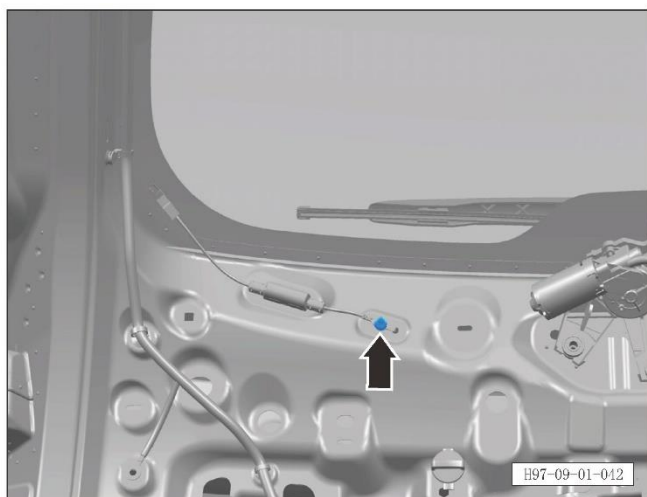

- a. Unscrew 1 fixing bolt of the negative filter.
Tightening torque of bolt: $8\pm 1\text{Nm}$.

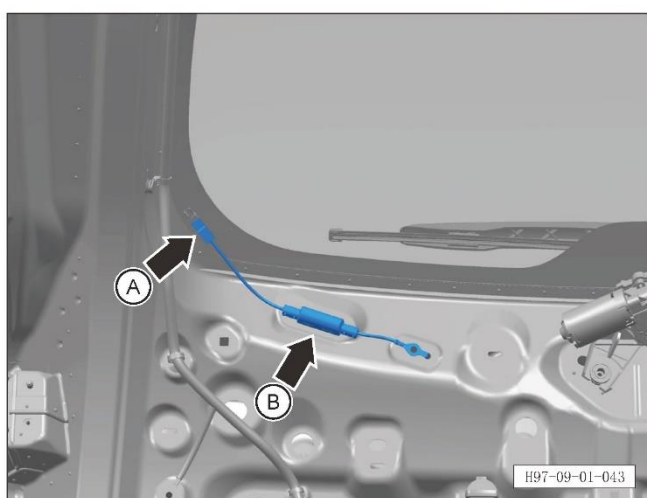

- b. Disconnect 1 connector A of the negative filter, and disengage the fixing clip B of the negative filter.

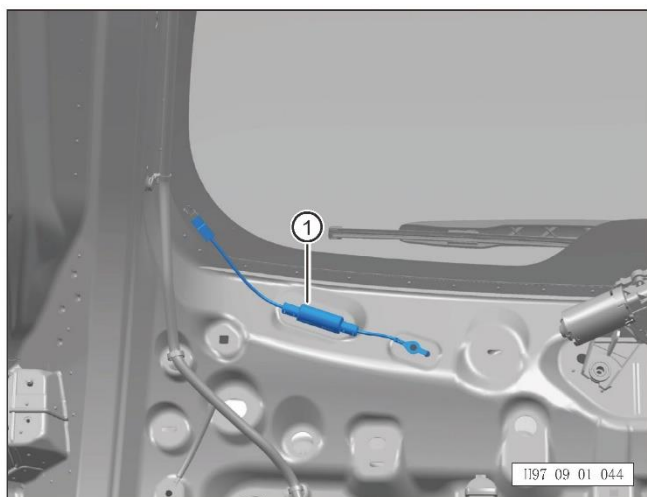

- c. Remove the negative filter ①.

Refitting procedure

The refitting procedure is performed in reverse order.

9.1.9 Microphone

9.1.9.1 Removal and refitting of microphone

Removal procedure

Note:

- The following is the removal and refitting of the left microphone, which can be referred to for the operations on the right side.

1. Turn off all electrical appliances and the start switch.

2. Disconnect the negative terminal of the battery (refer to [3.1.7.1 Maintenance and inspection of battery](#))

3. Remove the left microphone.

a. Disengage 2 fixing clips of the left microphone and disconnect the connector of the microphone .

b. Remove the left microphone ①.

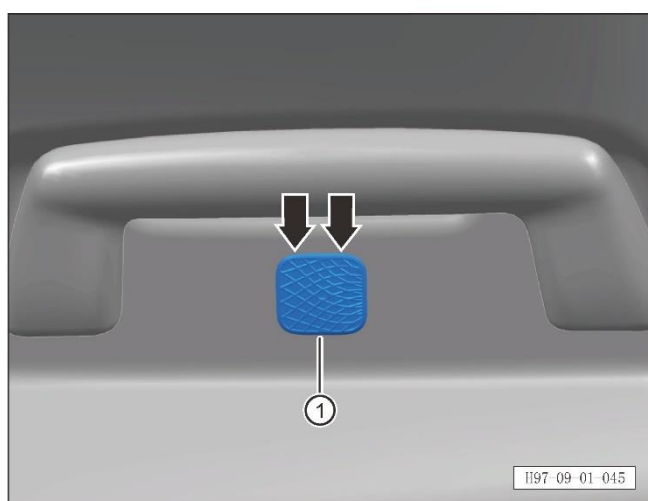

Refitting procedure

The refitting procedure is performed in reverse order.

9.1.9.2 Removal and refitting of single microphone

Removal procedure

Note:

- The following is the removal and refitting of the left single microphone, which can be referred to for the operations on the right side.

1. Turn off all electrical appliances and the start switch.

2. Disconnect the negative terminal of the battery (refer to [3.1.7.1 Maintenance and inspection of battery](#))

3. Remove the left single microphone.

a. Disengage the fixing clip of the left rear ceiling lamp, and disconnect the connector of the single microphone and the left rear ceiling lamp to remove the left rear ceiling lamp.

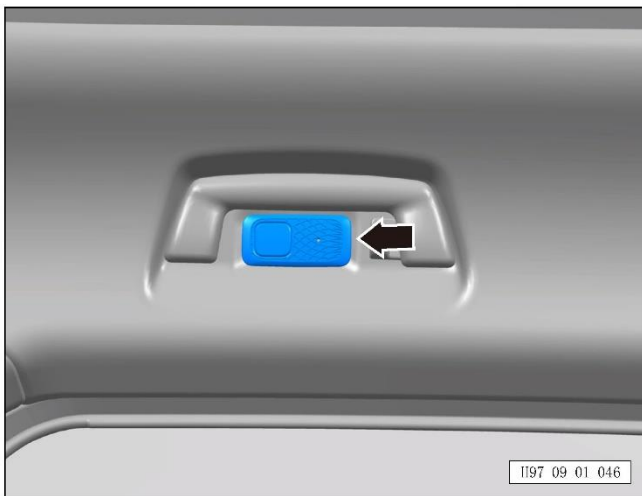

b. Disengage 4 fixing clips of the left single microphone to remove the left single microphone ①.

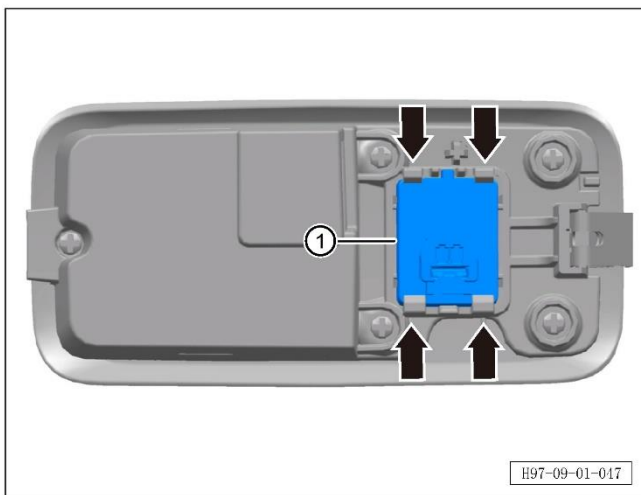

Refitting procedure

The refitting procedure is performed in reverse order.

9.1.9.3 Removal and refitting of dual microphone

Removal procedure

1. Turn off all electrical appliances and the start switch.
2. Disconnect the negative terminal of the battery (refer to [3.1.7.1 Maintenance and inspection of battery](#))
3. Remove the front ceiling lamp (refer to [9.9.11.2 Removal and refitting of front ceiling lamp assembly](#))
4. Remove the dual microphone.
 - a. Disengage 4 fixing clips of the front ceiling lamp.

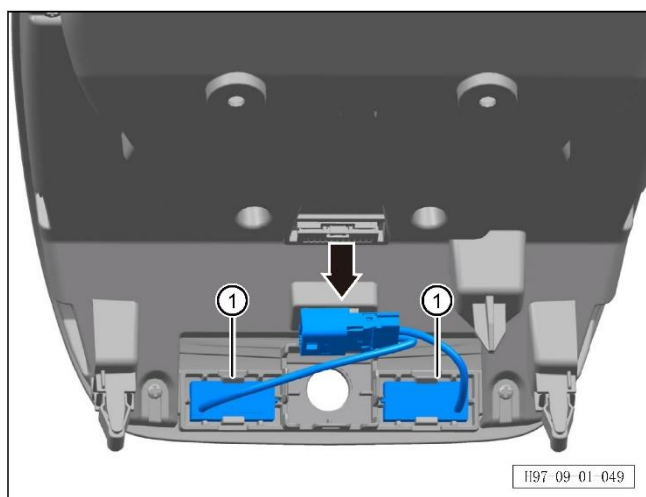
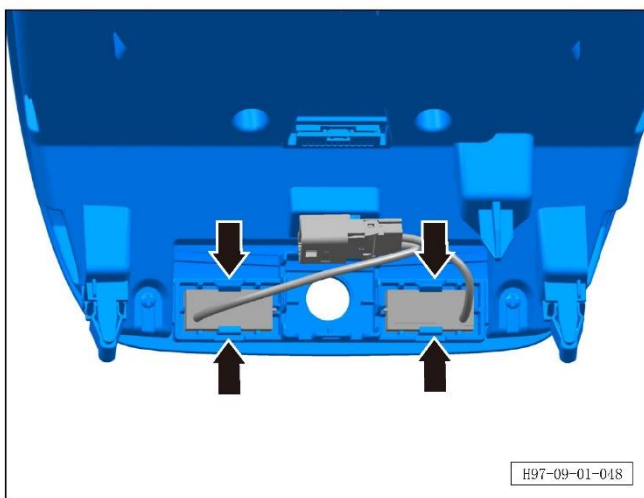

- b. Disengage the fixing clip of the dual microphone to remove the dual microphone ①.

Refitting procedure

The refitting procedure is performed in reverse order.

9.2 T-BOX

9.2.1 Description and operation

System overview

T-BOX is a product developed to tailor to VOYAH's needs based on Huawei's 5G platform. This product is based on NAD+MCU core architecture, in which NAD adopts self-developed 5G in-vehicle module MH5000-871 and supports LTE Cat16; MCU is a InfineonTC377 in-vehicle MCU; The hardware supports 5G Internet access (downward compatibility), V2X communication, 1,000 M Ethernet, two-way high-speed CAN, WiFi, dual GPS, xCALL communication, large-capacity EMMC storage, eSIM, G-sensor, hardware encrypted HSM, battery backup, etc.

The main functions supported by the T-BOX platform include: CAN communication (two-way high-speed CAN among which one way is used while the other one is reserved), Ethernet communication, wireless Internet access, emergency call (hardware reserved), location service, time service, remote service, remote diagnosis, remote control, remote upgrade, data mining, driving track reporting, IHU T business supporting, shared GPS data, national standard data collection and reporting of new energy vehicles (as required by GB/T 32960), remote one-key car search, one-key cooling, one-key heating, one-key engine warm up, remote charging reservation, mobile warning, collision warning, etc.

9.2.2 Position diagram of parts



9.2.3 Electrical schematic diagram

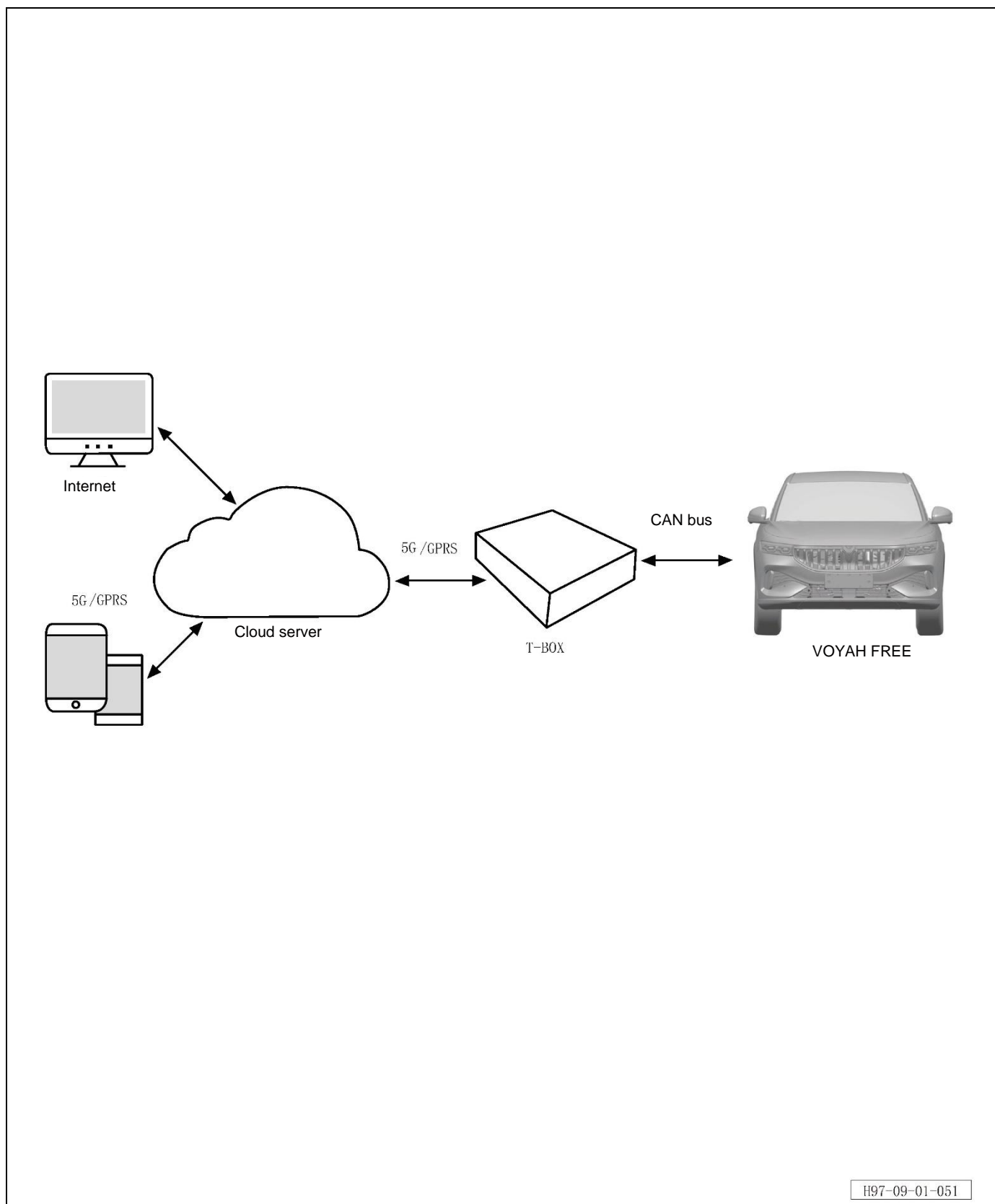

9.2.4 T-BOX

9.2.4.1 Removal and refitting of T-BOX

Removal procedure

1. Turn off all electrical appliances and the start switch.
2. Disconnect the negative terminal of the battery (refer to [3.1.7.1 Maintenance and inspection of battery](#))
3. Remove the right rear side wall inner trim panel assembly (refer to [8.5.5.10 Removal and refitting of rear side wall inner trim panel assembly](#))
4. Remove the right D-pillar upper protective plate assembly (refer to [8.5.5.9 Removal and refitting of right D-pillar upper protective plate](#))
5. Remove the T-BOX.

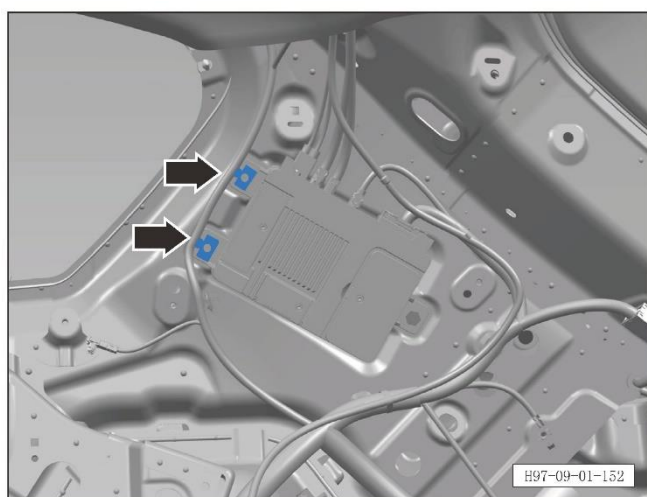

- a. Disengage 2 harness clips on the stud.

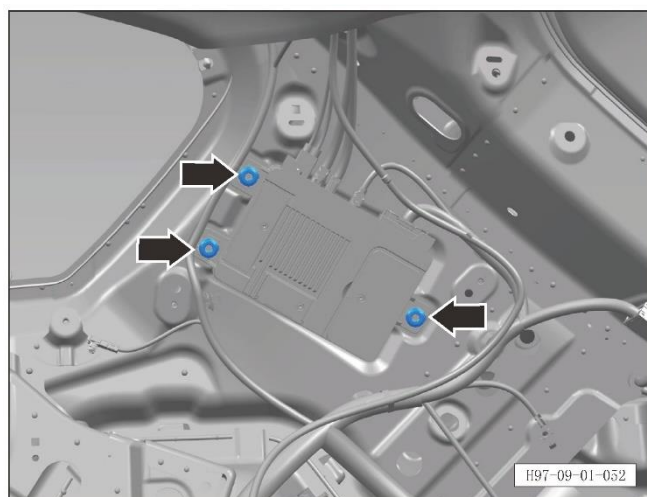

- b. Unscrew 3 fixing nuts of the T-BOX.
Tightening torque of nut: $8\pm 1\text{Nm}$.

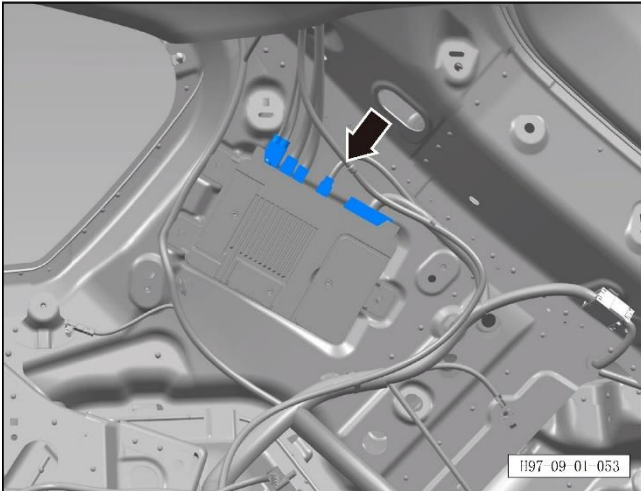

c. Disconnect 5 connectors of T-BOX.

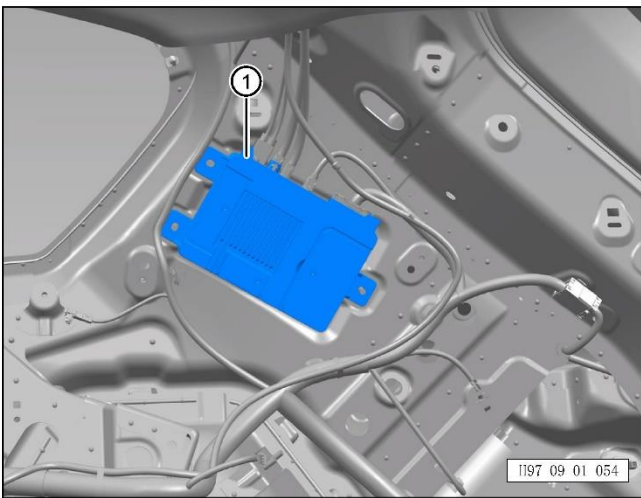

d. Remove the T-BOX ①.

Refitting procedure

The refitting procedure is performed in reverse order.

9.3 Sound signal system

9.3.1 Description and operation

Overview of horn system

The control method of the horn is to control the power supply terminal, that is, the horn switch controls the pull-in of the horn relay, and then the relay provides power to the horn. Horns are always grounded. At the same time, after receiving the driving requirements of the driving horn from other related systems through CAN communication, the BCM will drive and control the horn according to the relevant control strategies to realize related functions.

Overview of VSP system

When EVs and REVs drive at low speed in pure electric mode, the noise outside the vehicle is significantly reduced compared with traditional internal combustion engine vehicles, which makes it harder for other road users, including pedestrians, cyclists, etc., especially the blind persons and those with visual impairments to detect the approaching vehicles, thus leading to possible traffic accidents. Therefore, a VSP device is added to the vehicle to avoid the occurrence of accidents.

Function introduction

S/N	Vehicle status	AVAS status
1	Vehicle Ready status & VSP ON status & intact VSP & in D/N position & vehicle speed greater than 1 km/h and less than 30 km/h	The AVAS varies with the vehicle speed and gives out a D gear sound
2	Vehicle Ready status & VSP ON status & intact VSP & in D/N position & vehicle speed greater than or equal to 30 km/h or vehicle speed less than 1 km/h	AVAS stops sounding
3	Vehicle Ready status & VSP ON status & VSP no fault & gear in R position & vehicle speed greater than 1km/h and less than 30km/h	AVAS gives out a reversing warning tone
4	Vehicle Ready status & VSP ON status & intact VSP & in R position & vehicle speed greater than or equal to 30 km/h or vehicle speed less than 1 km/h	AVAS stops sounding
5	Turn off the warning sound via IVI	AVAS stops sounding
6	Power off the vehicle and start the vehicle again	AVAS ON
7	The vehicle detects VSP fault	AVAS stops sounding

Working principle: after the power supply voltage is protected by reverse connection, overvoltage, filtering, etc., it supplies power to the main parts of the system. The MCU processes the audio data in audio Flash through the messages (vehicle speed, gear position, engine status, etc.) obtained from CAN bus, and sends the processed data to the input of the power amplifier. After the signal of the power amplifier is amplified, it drives the speaker and gives a corresponding warning tone.

9.3.2 Position diagram of parts

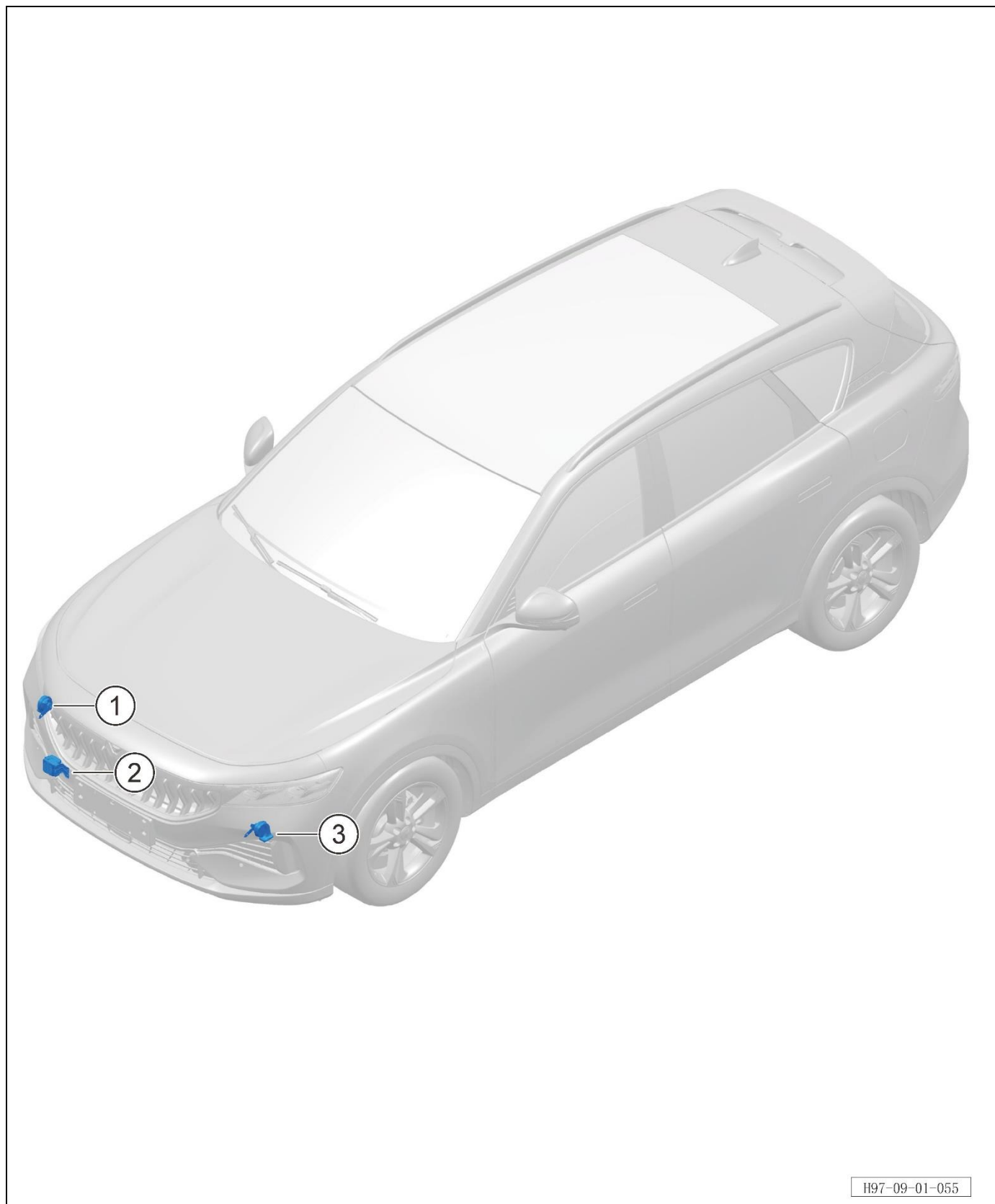

S/N	Part name	Loading quantity	Remarks
1	Woofer	1	
2	PAS controller	1	
3	High-tone horn	1	

9.3.3 Electrical schematic diagram of speaker system

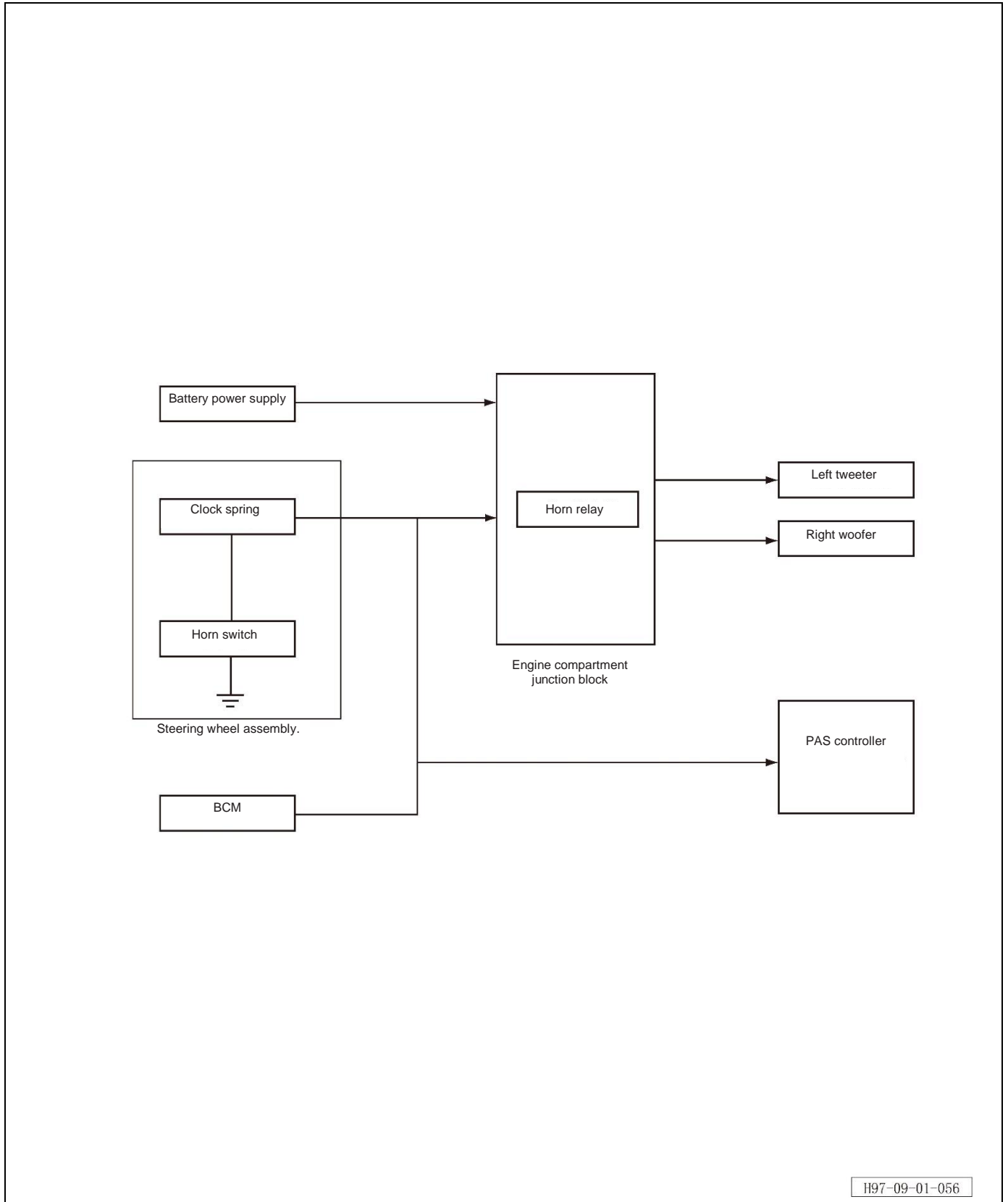

9.3.4 Electrical schematic diagram of VSP system

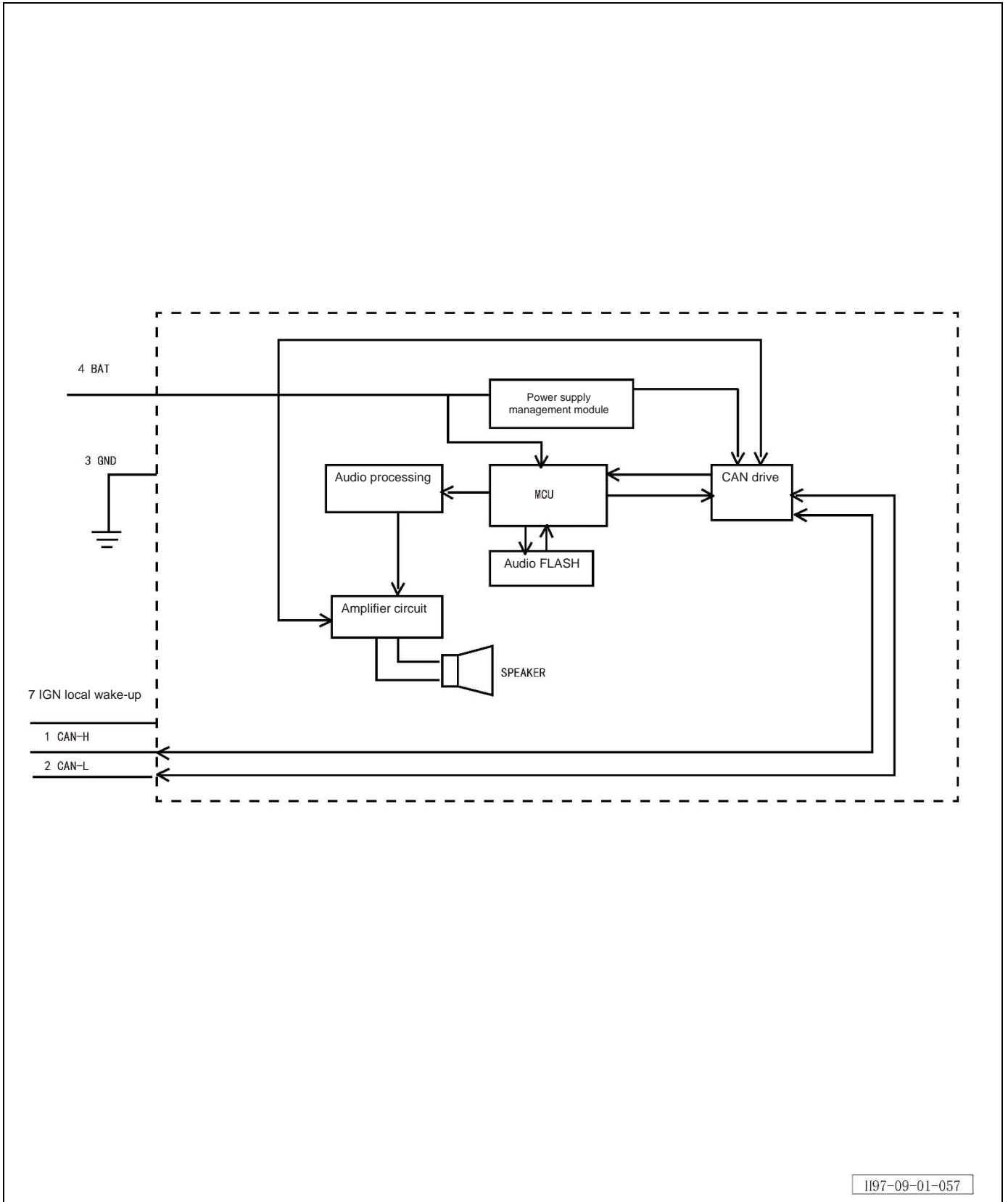

9.3.5 Horn

9.3.5.1 Removal and refitting of woofer

Removal procedure

1. Turn off all electrical appliances and the start switch.
2. Disconnect the negative terminal of the battery (refer to [3.1.7.1 Maintenance and inspection of battery](#))
3. Remove the front bumper assembly (refer to [8.6.3.3 Removal and refitting of front bumper assembly](#))
4. Remove the woofer.

a. Unscrew 1 fixing nut of the woofer.

Tightening torque of nut: $8\pm 1\text{Nm}$.

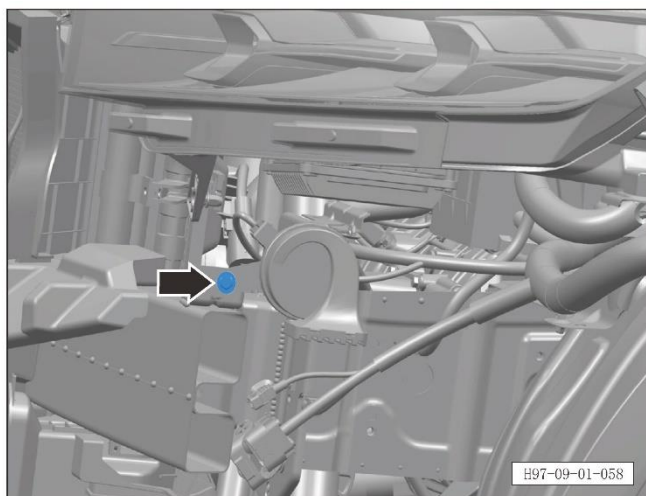

b. Disconnect the connector of the woofer.

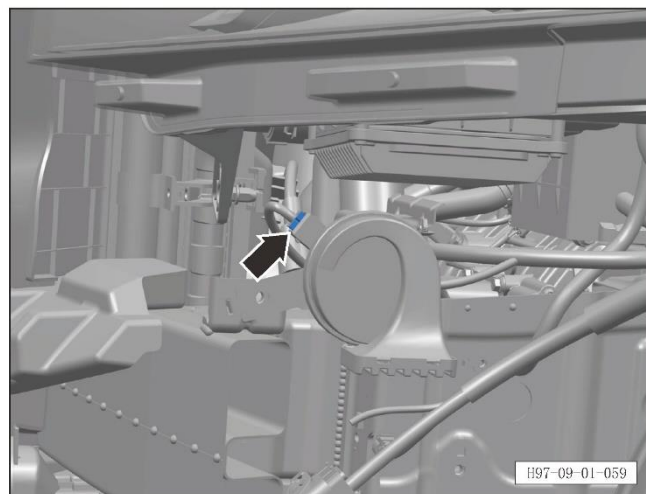

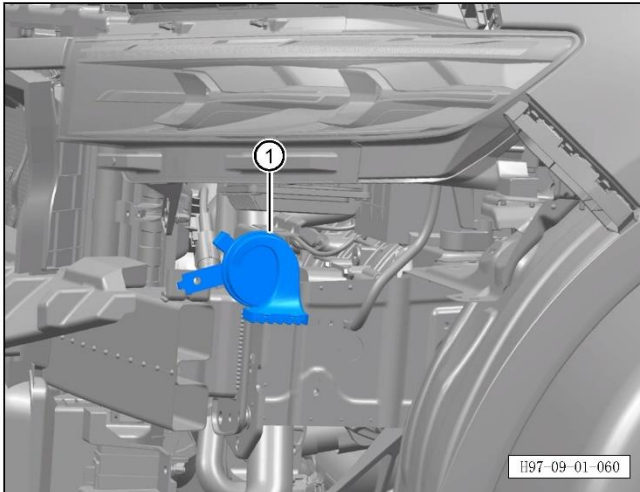

c. Remove the woofer ①.

Refitting procedure

The refitting procedure is performed in reverse order.

9.3.5.2 Removal and refitting of tweeter

Removal procedure

1. Turn off all electrical appliances and the start switch.
2. Disconnect the negative terminal of the battery (refer to [3.1.7.1 Maintenance and inspection of battery](#))
3. Remove the front bumper assembly (refer to [8.6.3.3 Removal and refitting of front bumper assembly](#))
4. Remove the tweeter.

- a. Unscrew 1 fixing bolt of the tweeter.
Tightening torque of bolt: $8\pm 1\text{Nm}$.

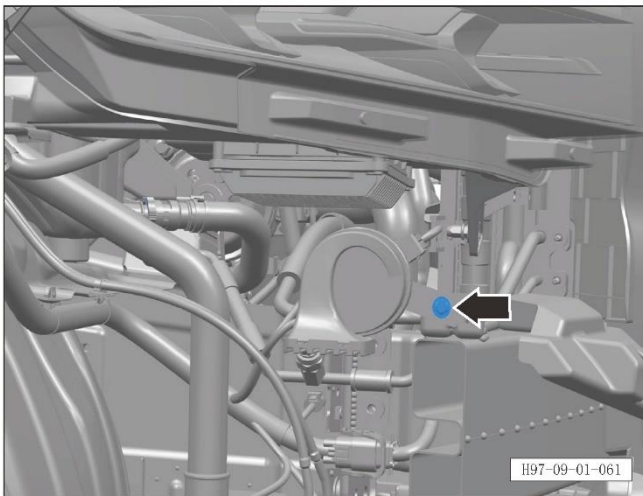

- b. Disconnect the connector of the tweeter .

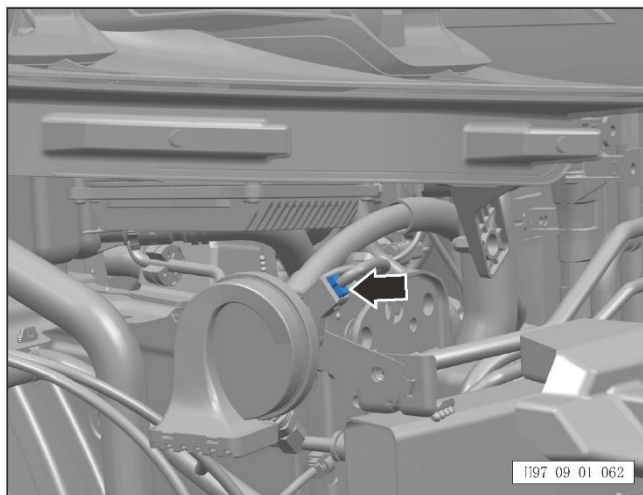

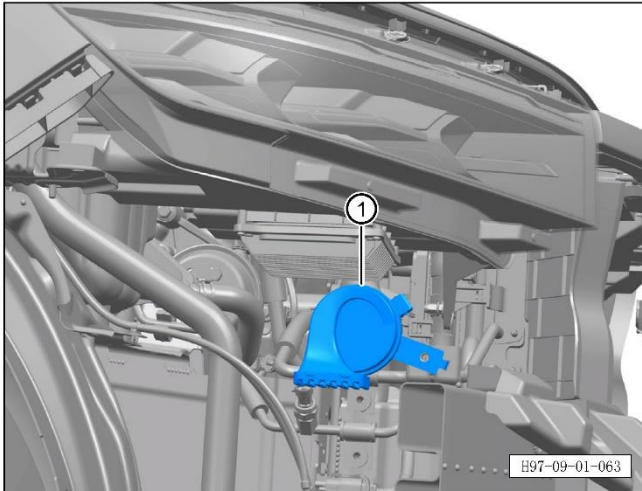

c. Remove the tweeter ①.

Refitting procedure

The refitting procedure is performed in reverse order.

9.3.6 VSP

9.3.6.1 Removal and refitting of VSP controller

Removal procedure

1. Turn off all electrical appliances and the start switch.
2. Disconnect the negative terminal of the battery (refer to [3.1.7.1 Maintenance and inspection of battery](#))
3. Remove the front bumper assembly (refer to [8.6.3.3 Removal and refitting of front bumper assembly](#))
- 4 Remove the VSP controller.

- a. Unscrew 2 fixing bolts of the VSP controller.
Tightening torque of bolt: $8\pm 1\text{Nm}$.

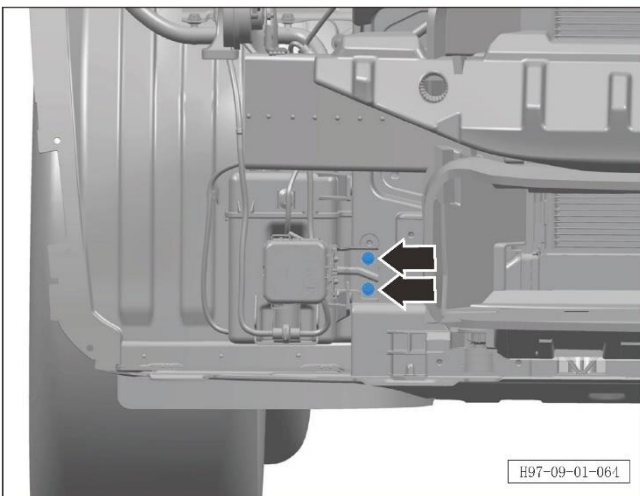

- b. Disconnect the connector of the VSP controller.

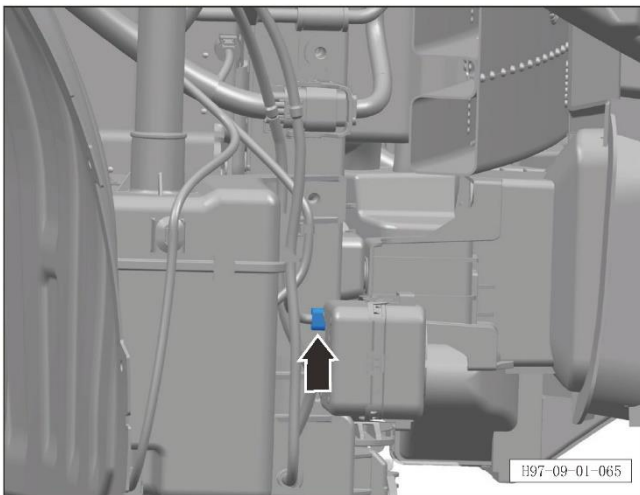

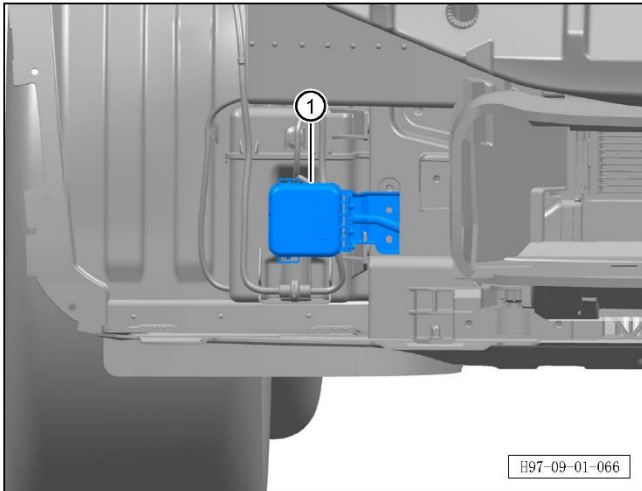

c. Remove the VSP controller ①.

Refitting procedure

The refitting procedure is performed in reverse order.

9.4 LV power supply system

9.4.1 Description and operation

System overview

This model is equipped with mobile phone wireless charging function, two 12 V power interfaces, 3 USB charging interfaces and 1 TYPE-C interface. The two 12 V power interfaces are separately set on the lower part of the front console and the right of the trunk, and the USB charging interface is set on the lower part of the front console (both transmit readable data and support mainstream mobile phone for fast charging with charging speed of 5V/2.1A, or 10.5 W) and the lower part of the rear console (1 USB interface supports QC3.0 18W; 1 TYPE-C interface supports PD 60W; Both interfaces do not support data transmission). The 12 V power charging interface supplies 12 V DC power to adapt to some off-board electronic devices (mobile phone charging, on-board MP3, navigator, etc.).

Introduction to wireless charging function

The mobile phone wireless charging is to charge the mobile phone via electromagnetic induction instead of using wires.

Mobile phone wireless charging is enabled by default.

You can enable or disable the wireless charging function in the CSD settings through Body control → Vehicle anti-theft alarm → Wireless charging.

Description of wireless charging working status:

Working status	Display	Description
Not charged	Green lamp turns off after 3 s	Enabling
Charging	Green lamp remains flashing	Charging
Charging completed	Green lamp always on	Charging completed
Charging fault	Green lamp off, red lamp on	Charging fault

9.4.2 Warning and notice

Warning for disconnection of battery

Warning!

- Before servicing the electrical components, all electronics and engine start/stop button must be turned off, unless otherwise stated in operating procedures.
- Disconnect the negative terminal of the battery if the tool or device easily touches the exposed live terminal. Failure to follow these safety instructions may result in personal injury and damage to the vehicle.

Notes on disconnecting the battery

Caution!

- When connecting or disconnecting the battery cable, battery charger, or jumper cable, you must set the engine start/stop button to OFF position. Failure to do so may result in damage to the control module or other electrical components.

Warning about the function of the mobile phone wireless charging

Warning!

- Please do not charge the mobile phone in the vehicle when the driver is not in the vehicle, so as to avoid potential safety hazards;
- Please do not check the charging status of the mobile phone for a long time when driving the vehicle, so as to avoid potential traffic safety hazards;
- Please do not place heavy objects in the charging area to avoid damage to the mobile phone wireless charging system;
- please stop using the product if it is faulty and cannot be used normally, and go to an authorized VOYAH Service Center for maintenance in time;
- The company does not assume any responsibility for any problems caused by abnormal use (such as external wireless charging coils, etc.); If the product has been disassembled or modified, the free warranty service will be terminated;
- Please start charging after making sure there are no metal foreign objects in the back of the phone and the front storage box as it has a heating effect on metal, otherwise the metal foreign objects may be heated or damaged, and even lead to safety accidents. The metal foreign matters here refer to other objects containing metal components, including but not limited to coins, keys, chips, magnetic cards, etc.;
- Please turn off the wireless charging function through the CSD menu first if you want to place metal foreign objects in the front storage box, so as to avoid the safety hazard caused by the metal sliding into the charging area during driving;
- Do not spill water in the front storage box, so as to prevent water from entering the wireless charging module and thus causing damage to electronic devices;
- Please use it with caution as our company does not make commitments for the problem caused by the external wireless charging coil.

Notes on the wireless charging function of mobile phones

Caution!

- Only one mobile phone can be charged at the same time;
- Please try to ensure that the center of the mobile phone is aligned with the Qi logo in the front storage box in order to ensure the normal charging of the mobile phone;
- On bumpy roads, mobile phone wireless charging may intermittently stop and resume. If the mobile phone deviates from the charging area and stops charging, the mobile phone needs to be moved back to the charging area;
- Phone charging may stop when the temperature is too high (greater than 85°) or too low (below -40°), and will continue charging when the temperature drops.

9.4.3 Position diagram of parts

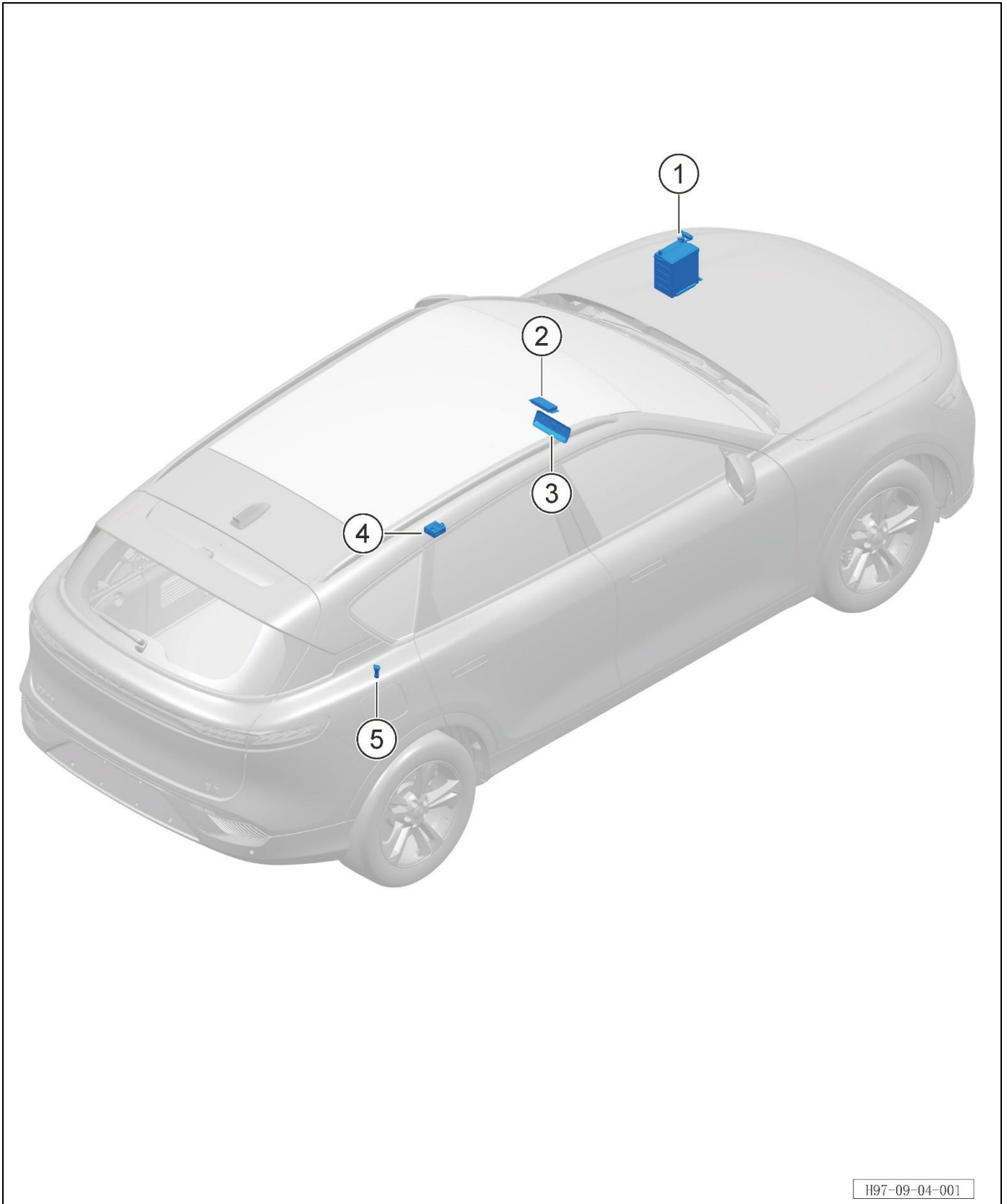

S/N	Part name	Loading quantity	Remarks
1	Batteries and accessories	1	
2	Mobile phone wireless charging controller	1	
3	Console 12 V power socket and USB	1	
4	USB charger	1	
5	Trunk 12 V power socket	1	

9.4.4 LV battery and accessories

9.4.4.1 Removal and refitting of battery (REV)

Removal procedure

1. Turn off all electrical appliances and the start switch.
2. Remove the engine compartment left front trim panel assembly (refer to [8.6.6.10 Removal and refitting of engine compartment left front trim panel assembly](#))
3. Remove the engine compartment front middle trim panel assembly (refer to [8.6.6.11 Removal and refitting of engine compartment front middle trim panel assembly](#))
4. Remove the battery.

- a. Unscrew 2 fixing bolts of the battery mounting plate.

Tightening torque of bolt: $10\pm 1\text{Nm}$.

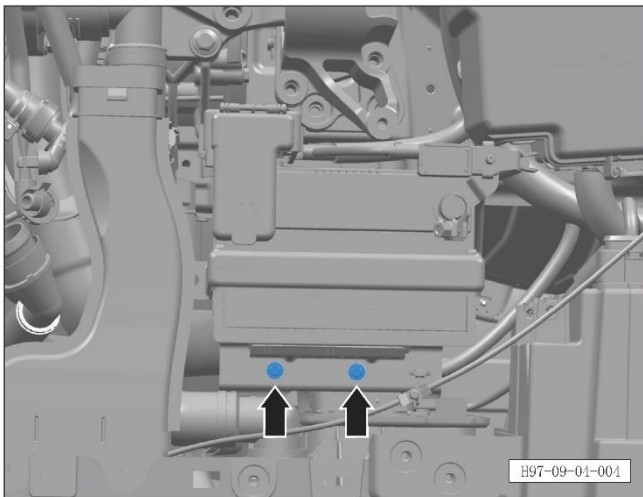

- b. Remove the battery mounting plate.

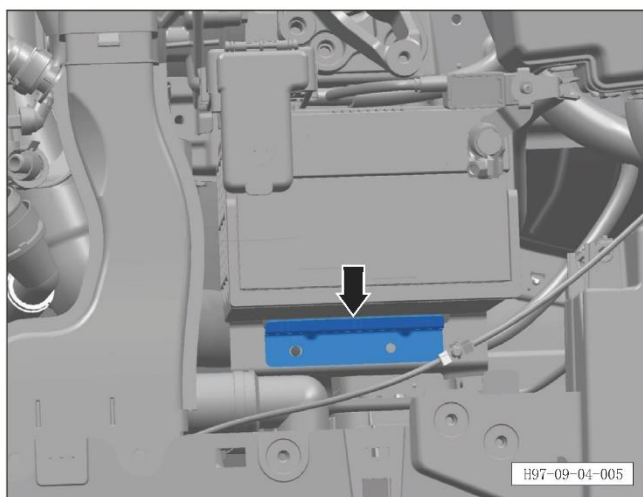

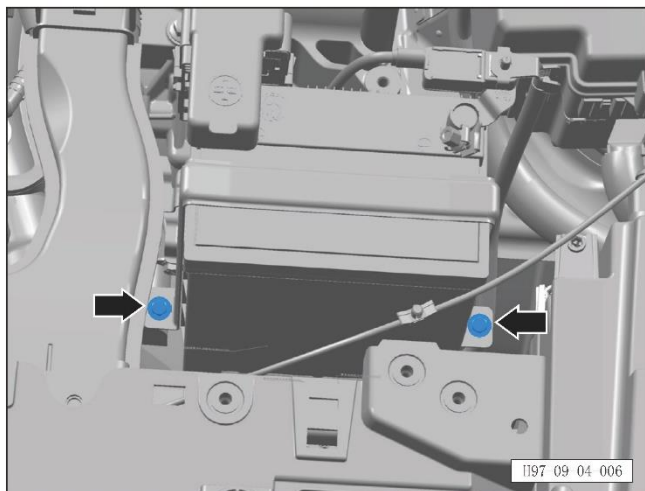

c. Unscrew 2 fixing bolts of the battery fixing strap.
Tightening torque of bolt: $10\pm 1\text{Nm}$.

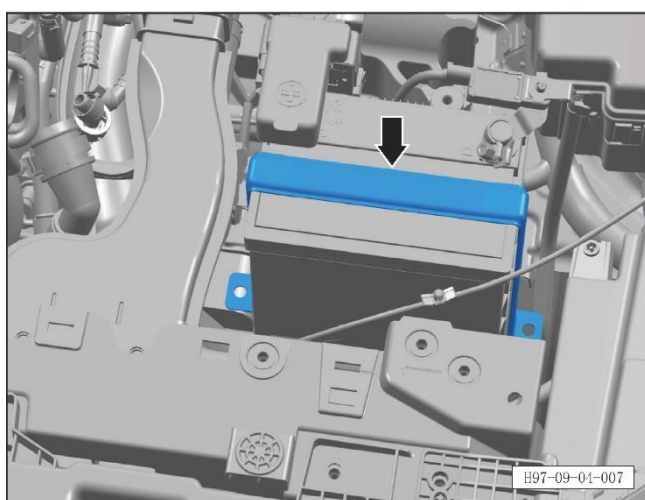

d. Remove the battery fixing strap.

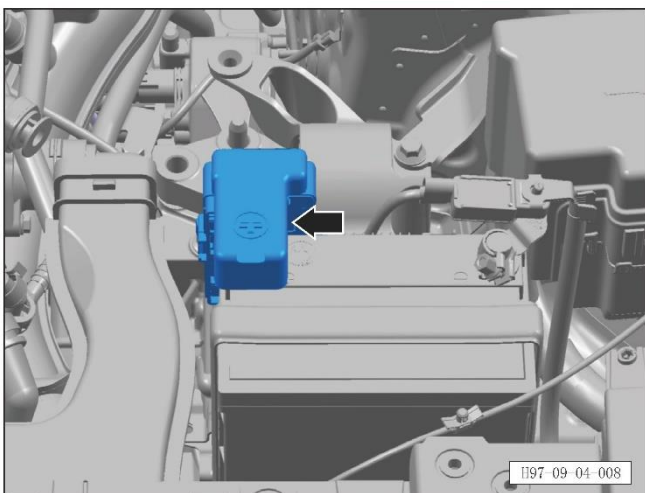

e. Disconnect the battery positive cable.

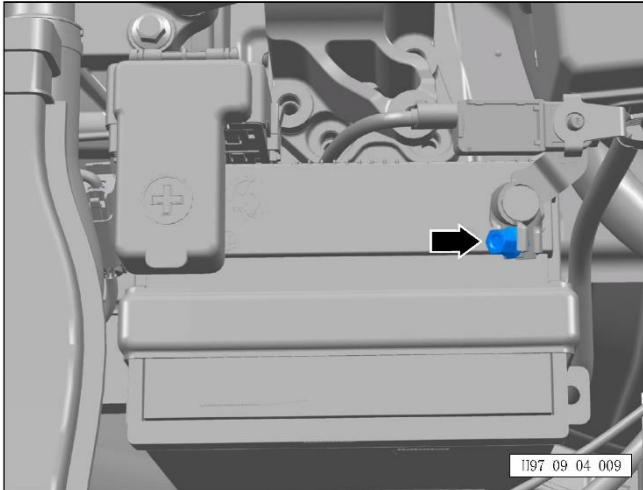

f. Loosen the fixing bolt of the battery negative cable.

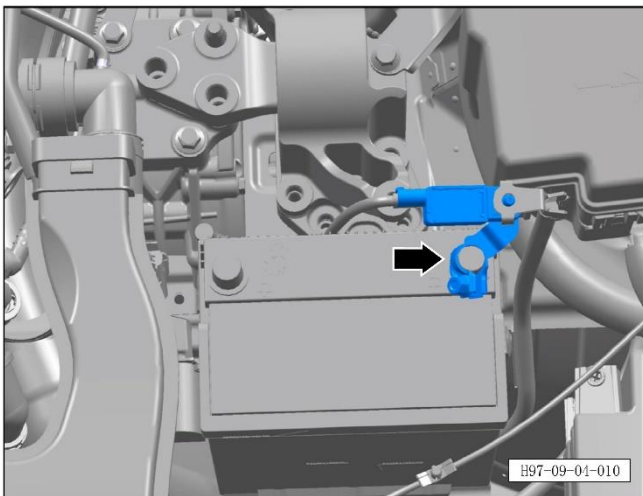

g. Remove battery negative cable.

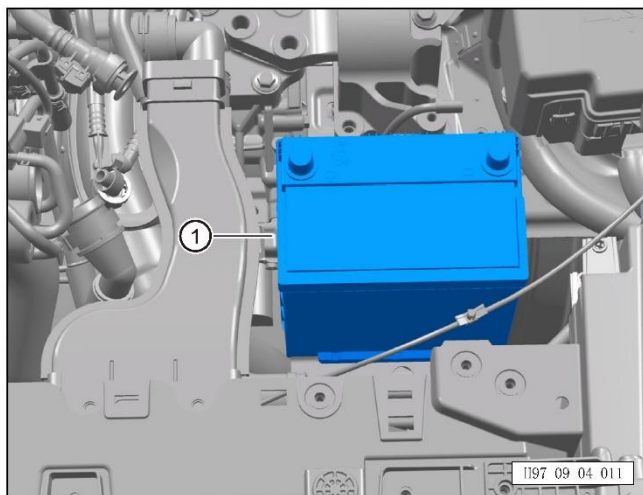

h. Take out the battery ①.

Refitting procedure

The refitting procedure is performed in reverse order.

9.4.4.2 Removal and refitting of battery (EV)

Removal procedure

1. Turn off all electrical appliances and the start switch.
2. Remove the engine compartment left front trim panel assembly (refer to [8.6.6.10 Removal and refitting of engine compartment left front trim panel assembly](#))
3. Remove the engine compartment front middle trim panel assembly (refer to [8.6.6.11 Removal and refitting of engine compartment front middle trim panel assembly](#))
4. Remove the engine compartment item box body (refer to [8.5.11.3 Removal and refitting of front engine compartment item box body](#))
4. Remove the battery.

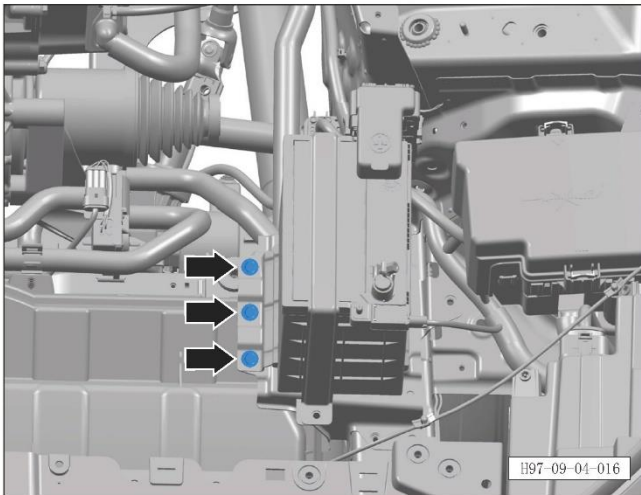

- a. Unscrew 3 fixing bolts of the battery mounting plate.

Tightening torque of bolt: $10\pm 1\text{Nm}$.

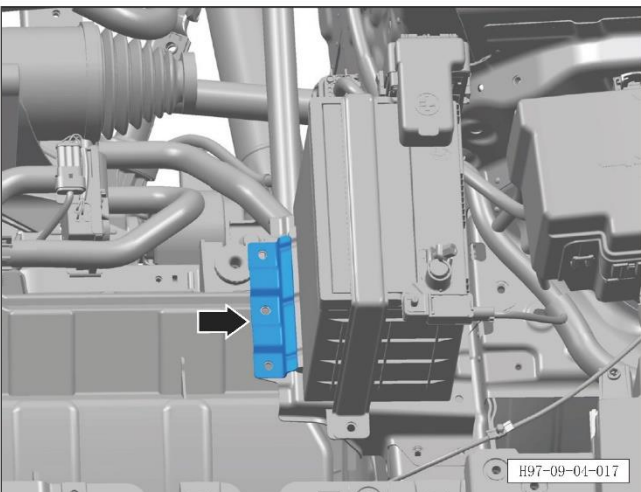

- b. Remove the battery mounting plate.

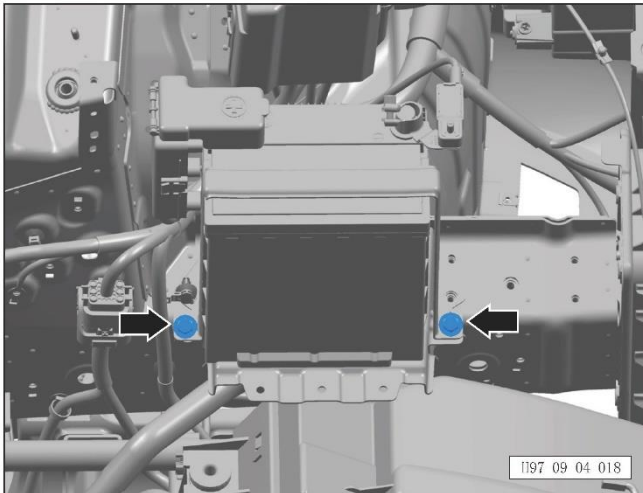

c. Unscrew 2 fixing bolts of the battery fixing strap.
Tightening torque of bolt: $10\pm 1\text{Nm}$.

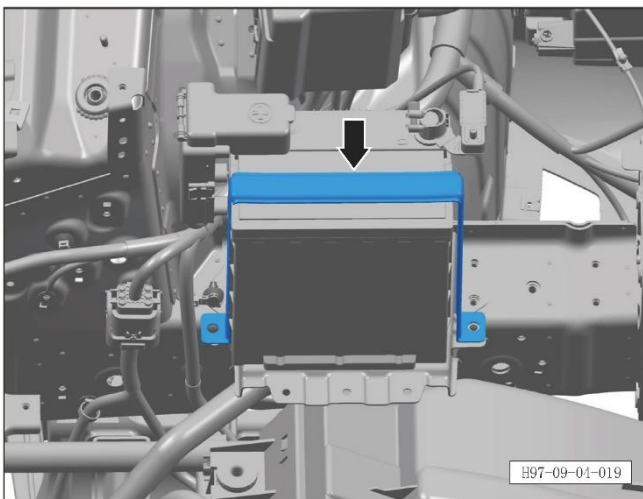

d. Remove the battery fixing strap.

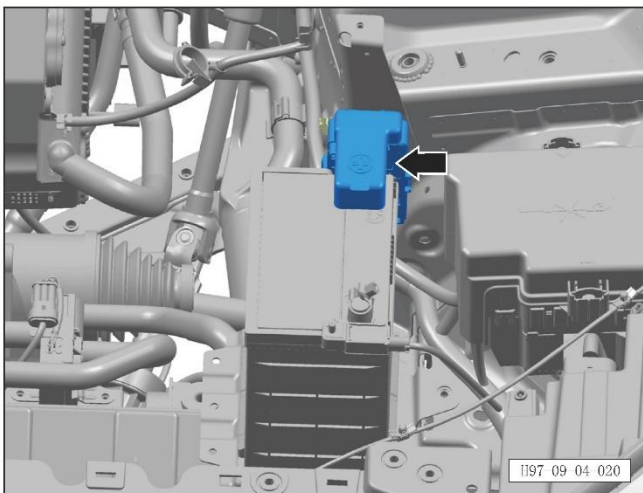

e. Disconnect the battery positive cable.

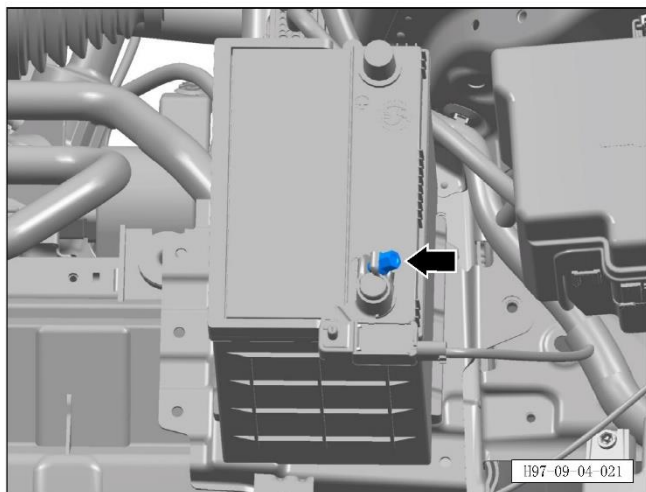

f. Loosen the fixing bolt of the battery negative cable.

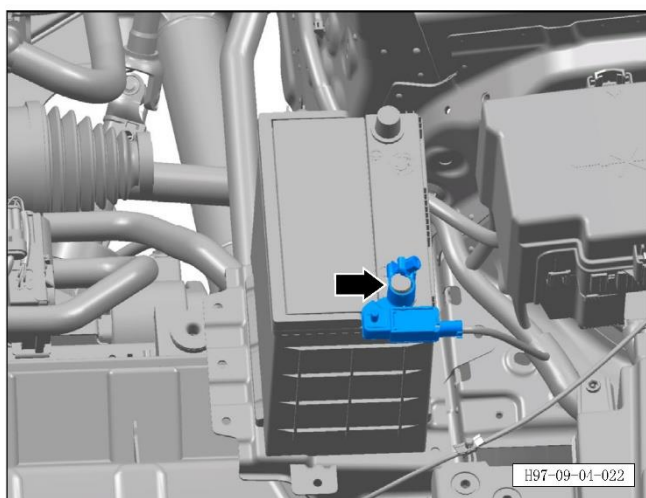

g. Remove battery negative cable.

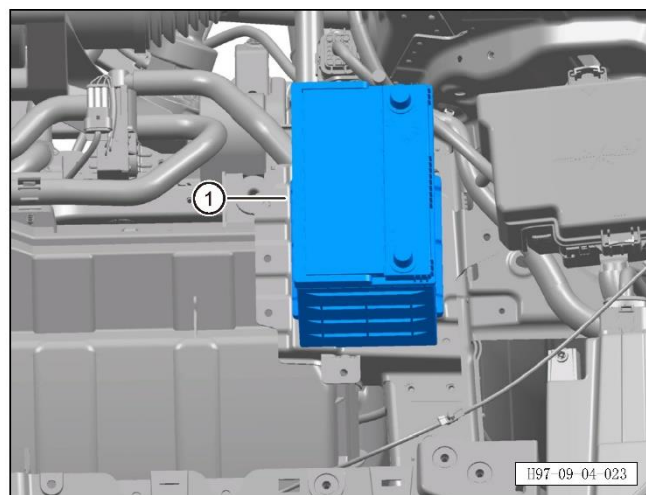

h. Take out the battery ①.

Refitting procedure

The refitting procedure is performed in reverse order.

9.4.4.3 Removal and refitting of battery sensor

Removal procedure

1. Turn off all electrical appliances and the start switch.

2. Remove the battery sensor.

a. Unscrew 1 fixing nut of the battery sensor.

Tightening torque of nut: $6\pm 1\text{Nm}$.

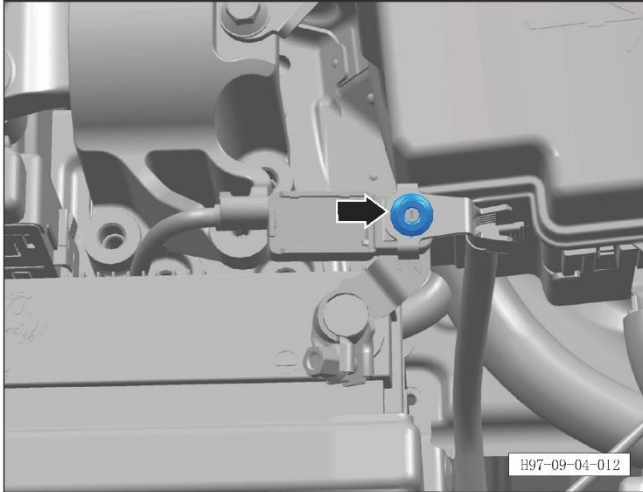

b. Disconnect the connector of the battery sensor.

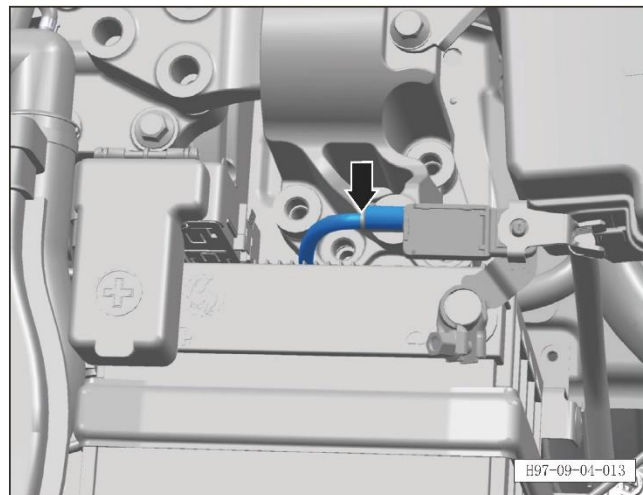

b. Disconnect the connector of the VSP controller.

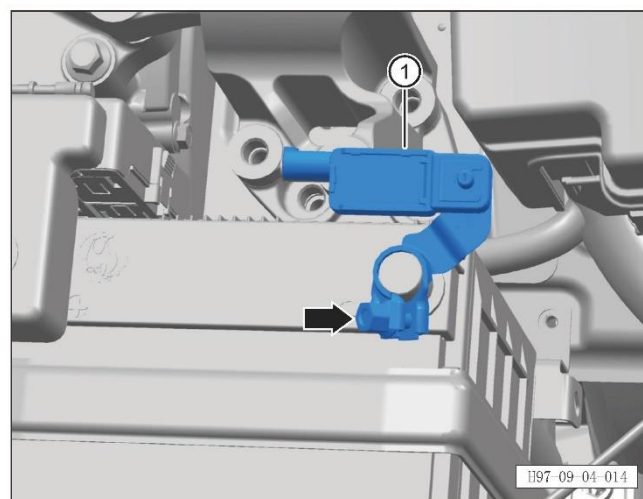

Refitting procedure

The refitting procedure is performed in reverse order.

9.4.5 Power supply 12 V interface

9.4.5.1 Removal and refitting of console 12 V power socket

Removal procedure

1. Turn off all electrical appliances and the start switch.
2. Disconnect the negative terminal of the battery (refer to [3.1.7.1 Maintenance and inspection of battery](#))
3. Remove the USB cover plate (refer to [8.3.4.14 Removal and refitting of USB cover plate](#))
4. Remove the 12 V power socket.
 - a. Disengage 2 fixing clips of the 12 V power socket to take out the 12 V power socket ①.

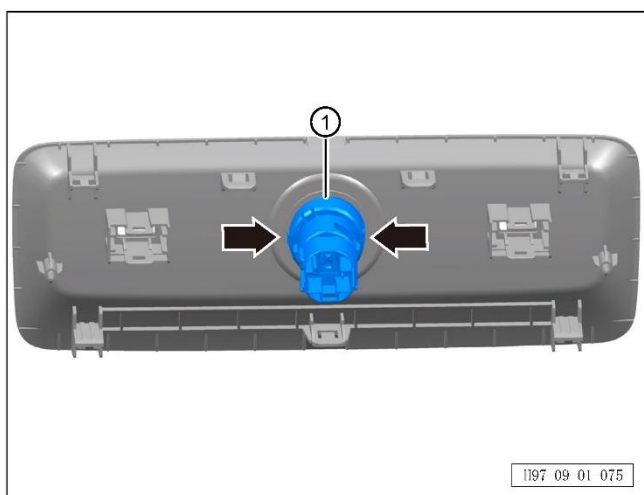

Refitting procedure

The refitting procedure is performed in reverse order.

9.4.5.2 Removal and refitting of trunk 12 V power socket

Removal procedure

1. Turn off all electrical appliances and the start switch.
2. Disconnect the negative terminal of the battery (refer to [3.1.7.1 Maintenance and inspection of battery](#))
3. Remove the trunk 12 V power socket.
 - a. Disengage 2 fixing clips of the 12 V power socket, and disconnect the connector to take out the 12 V power socket ①.

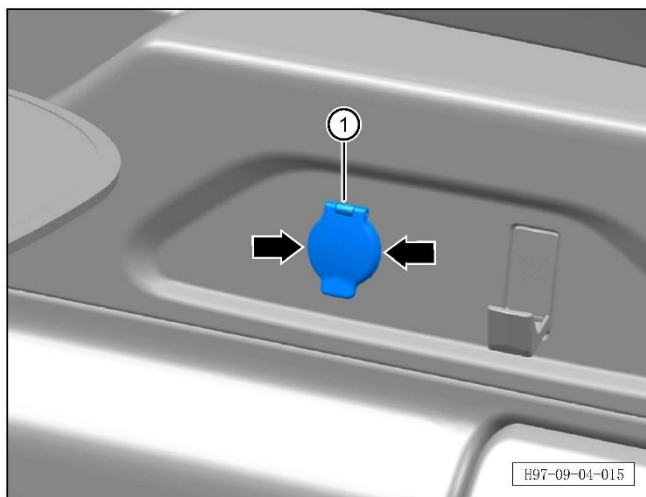

Refitting procedure

The refitting procedure is performed in reverse order.

9.4.5.3 Removal and refitting of USB charger

Removal procedure

1. Turn off all electrical appliances and the start switch.
2. Disconnect the negative terminal of the battery (refer to [3.1.7.1 Maintenance and inspection of battery](#))
3. Remove the armrest box rear cover plate assembly (refer to [8.3.4.6 Removal and refitting of armrest box rear cover plate assembly](#))
4. Remove the USB charger.

a. Disconnect the connector of the USB charger.



b. Disengage 4 fixing clips of the USB charger to remove the USB charger ①.

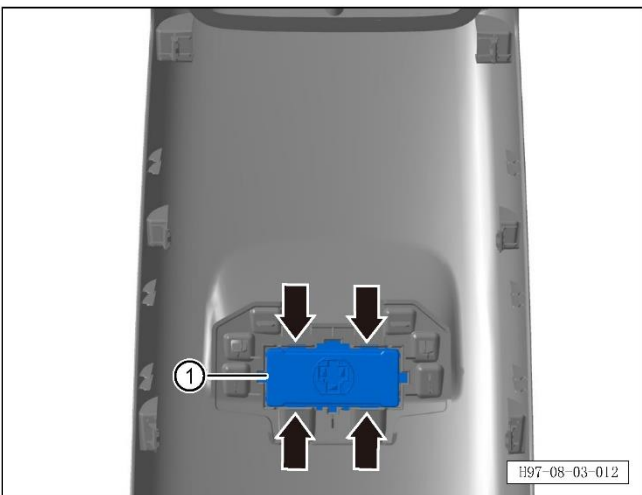

Refitting procedure

The refitting procedure is performed in reverse order.

9.4.6 Mobile phone wireless charging

9.4.6.1 Removal and refitting of mobile phone wireless charging controller

Removal procedure

1. Turn off all electrical appliances and the start switch.
2. Disconnect the negative terminal of the battery (refer to [3.1.7.1 Maintenance and inspection of battery](#))
3. Remove the upper panel assembly (refer to [8.3.4.2 Removal and refitting of upper panel assembly](#))
4. Remove the mobile phone wireless charging controller.

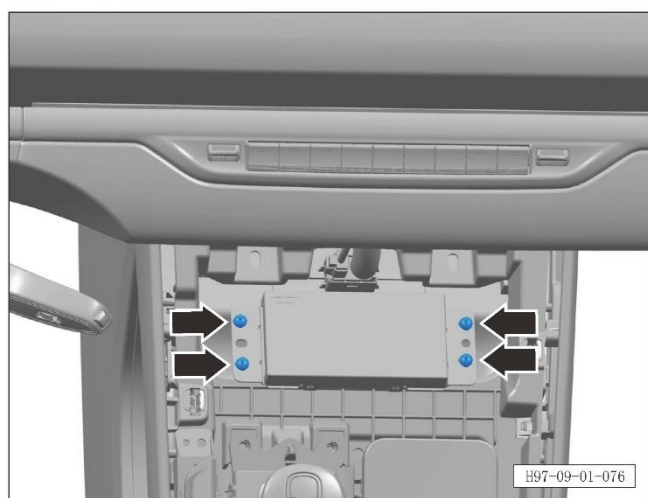

- a. Unscrew 4 fixing screws of the mobile phone wireless charging controller.

Tightening torque of screw: $4.5 \pm 0.5 \text{ Nm}$

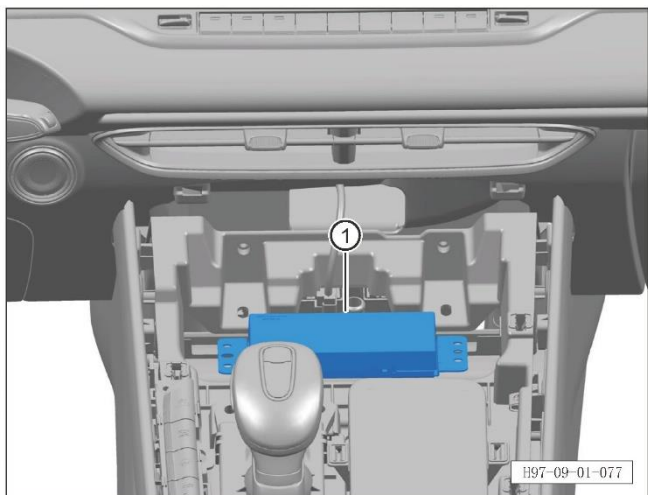

- b. Disconnect the connector of the mobile phone wireless charging controller to remove the mobile phone wireless charging controller ①.

Refitting procedure

The refitting procedure is performed in reverse order.

9.5 BCM

9.5.1 Description and operation

Gateway overview

Description of CAN communication system

CAN (Controller Area Network) is a real-time serial communication channel, which has on-board multiple-way communication channels with high communication rate and high fault tolerance. - There are multiple controllers on the vehicle that share information with each other. Each controller is connected by 2 communication lines (CAN-H line and CAN-L line). Each controller can send or receive data, but only selectively receives the data it needs.

Features of the CAN network of the vehicle

The vehicle has 4 CAN communication channels, among which channel 4# is vehicle CAN in which the gateway serves as routing to forward CAN information; Channel 1# is internal CAN.

1. Refined and dedicated network

– The entire network platform is divided into INFO (information), power, chassis, and body, and the information interaction of different subnets is coordinated through independent gateways.

2. Application of high-speed body CAN bus

– The CAN bus of the body is increased from 125 KB/s of the previous platform to 500 Kb/s, which solves the bottleneck of signal transmission, and improves the efficiency of signal transmission and the rapidity of system response.

9.5.2 Warning and notice

BCM

Warning for disconnection of battery

Warning!

- Before servicing any electrical components, the engine start/stop button shall be in OFF state and all electrical loads must be in "OFF" unless otherwise stated in the operating procedure. Disconnect the battery negative cable if the tools or devices easily touches the exposed live electrical terminal. Failure to follow these safety instructions may result in personal injury and damage to the vehicle or vehicle components.

Warning for road test

Warning!

- Test the vehicle on the road under the premise of ensuring safety and obey all traffic laws. Do not attempt anything that could endanger vehicle control. Failure to obey the above safety instructions can result in serious personal injury and damage to the vehicle.

Warning about the quick-lowering function of the windows

Warning!

- When the power window switch is operated from the driver side door, the quick lifting/lowering function will be enabled to make the window move extremely fast without stopping, which will possibly cause personal injury.

Precautions for setting the engine start/stop button to OFF position when disconnecting the battery

CAUTION:

- When connecting or disconnecting the battery cable, battery charger, or jumper cable, you must set the engine start/stop button to "OFF" position,

Failure to do so could result in damage to the control module or other electrical components.

9.5.3 Position diagram of parts

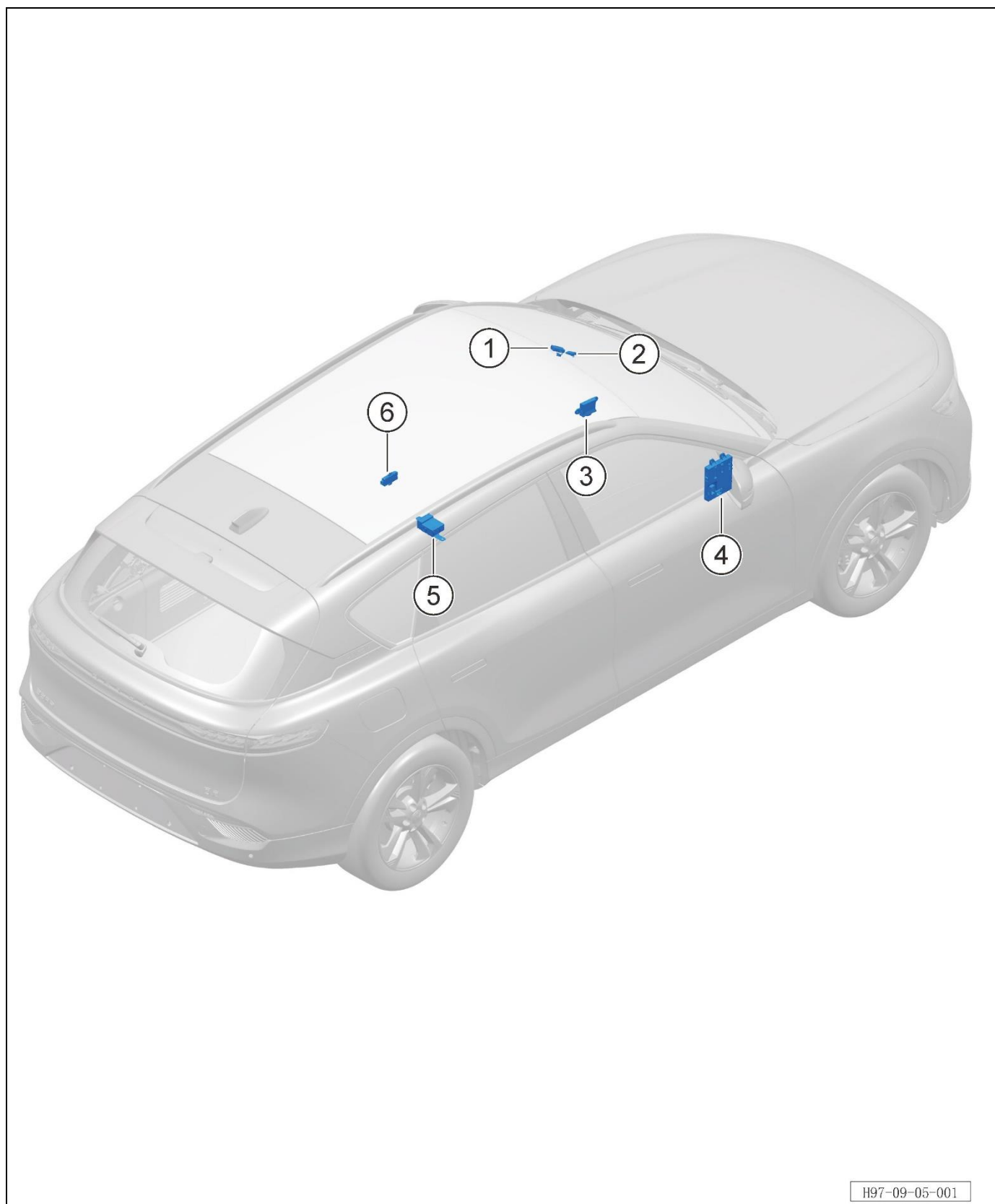

S/N	Part name	Loading quantity	Remarks
1	Electronic Toll Collection (ETC)	1	
2	Rain/light sensor	1	
3	Gateway	1	
4	Cabin central control box	1	
5	APM	2	
6	Flush door handle control unit	4	

9.5.4 Electrical schematic diagram

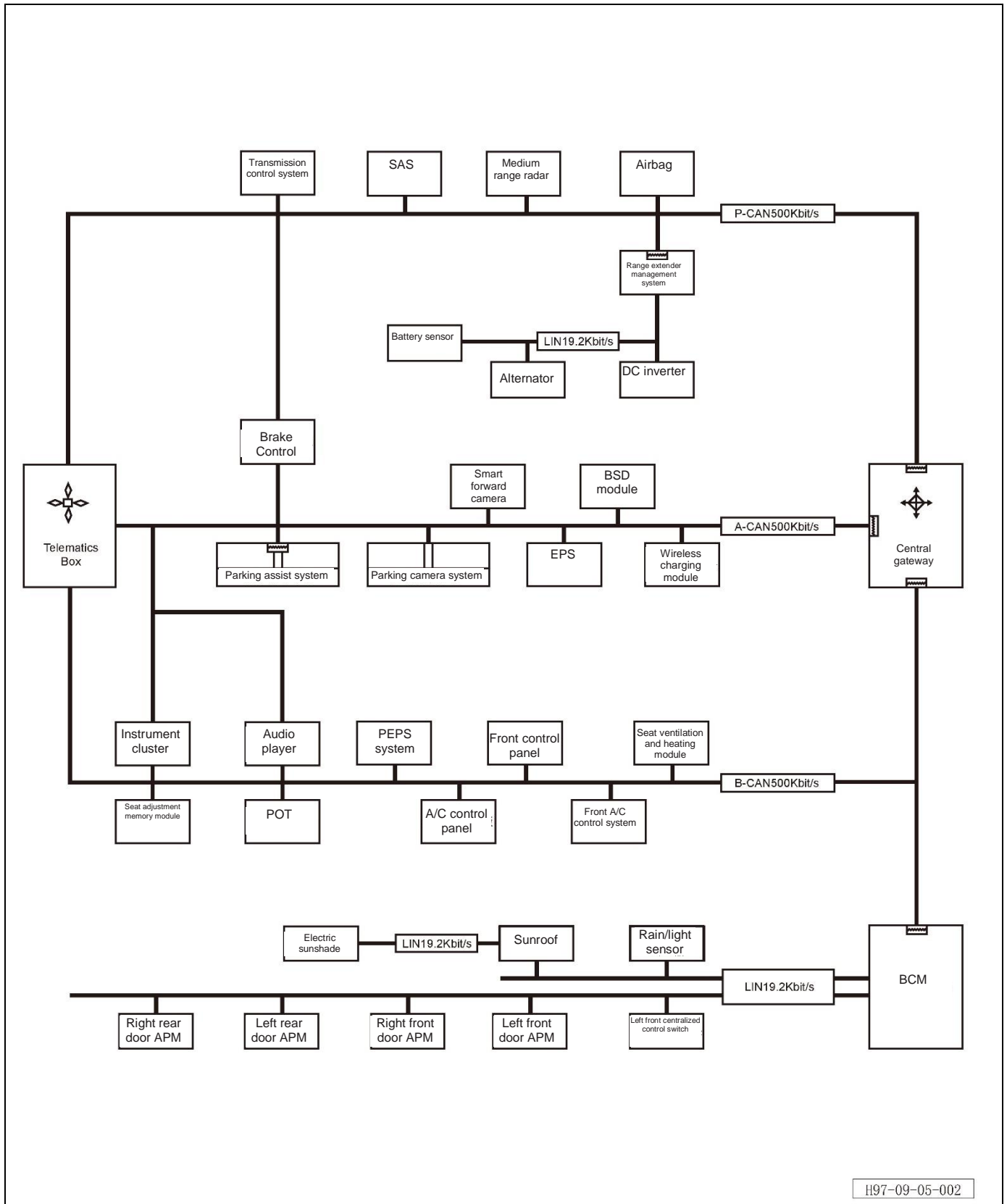

9.5.5 Gateway

9.5.5.1 Removal and refitting of gateway

Removal procedure

1. Turn off all electrical appliances and the start switch.
2. Disconnect the negative terminal of the battery (refer to [3.1.7.1 Maintenance and inspection of battery](#))
3. Remove the IP left lower bottom plate assembly (refer to [8.2.4.31 Removal and refitting of IP left lower bottom plate assembly](#))
4. Remove the gateway.

a. Unscrew 2 fixing bolts of the gateway.

Tightening torque of bolt: $6\pm 1\text{Nm}$.

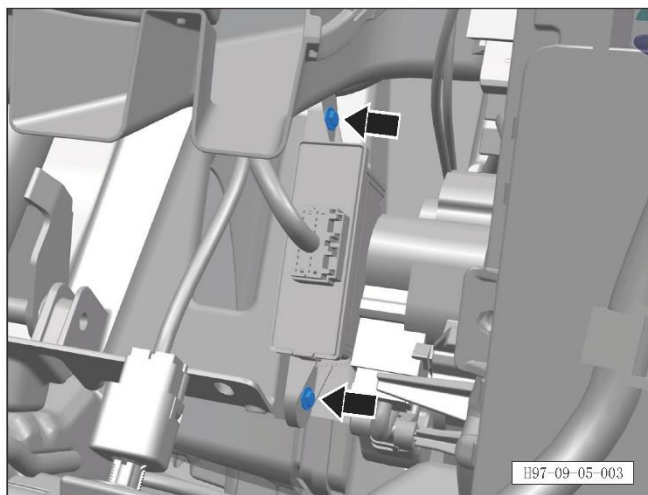

b. Disconnect the connector of the gateway.

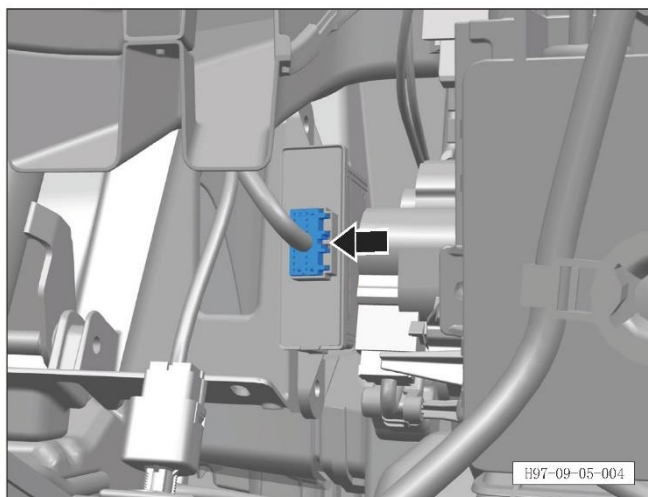

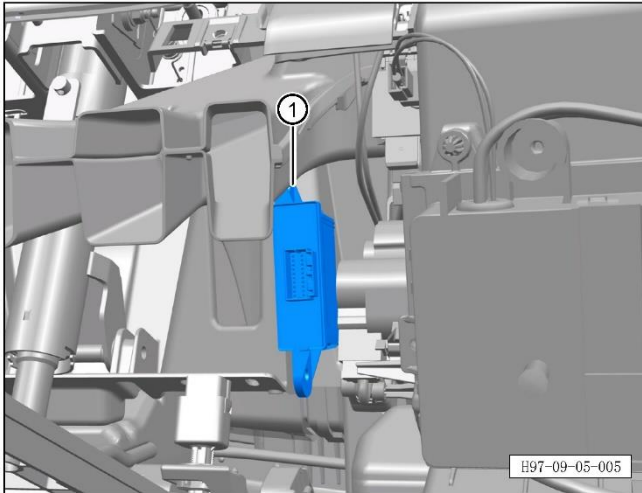

c. Remove the gateway ①.

Refitting procedure

The refitting procedure is performed in reverse order.

9.5.6 APM

9.5.6.1 Removal and refitting of APM

Removal procedure

1. Turn off all electrical appliances and the start switch.
2. Disconnect the negative terminal of the battery (refer to [3.1.7.1 Maintenance and inspection of battery](#))
3. Remove the front seat assembly (refer to [8.1.3.1 Removal and refitting of front seat assembly](#))
4. Remove the APM.

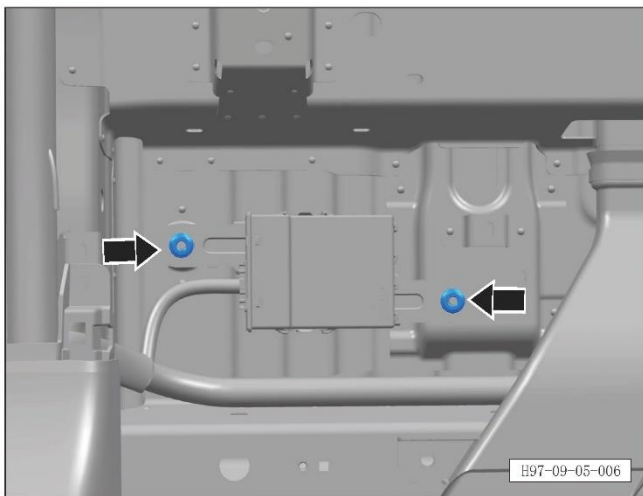

- a. Turn over the front of the rear carpet and the rear of the front carpet.
- b. Unscrew 2 fixing nuts of the APM.
Tightening torque of nut: $10\pm 1\text{Nm}$.

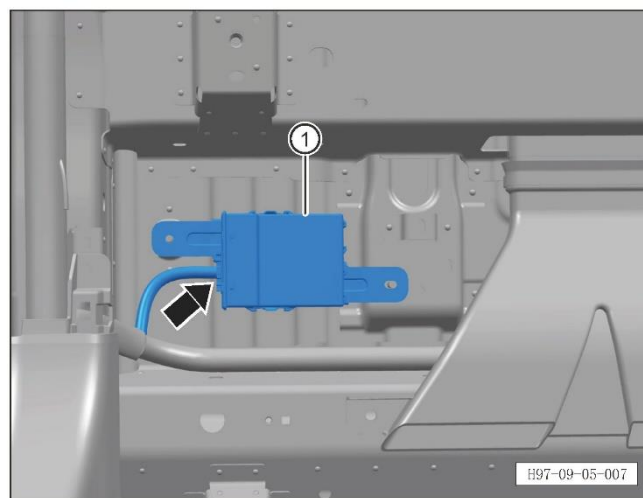

- c. Disconnect the connector of the APM to remove the APM ①.

Refitting procedure

The refitting procedure is performed in reverse order.

9.5.7 BCM

9.5.7.1 Removal and refitting of cabin central control box

Removal procedure

CAUTION:

- Remove and refit the controller carefully to avoid collision and prevent moisture.

- During remove and refitting, do not touch the pins of the connectors, or forcibly disassemble the housing, so as not to damage the internal electrical components.

1. Turn off all electrical appliances and the start switch.

2. Disconnect the negative terminal of the battery (refer to [3.1.7.1 Maintenance and inspection of battery](#))

3. Remove the instrument panel right lower bottom plate assembly (refer to [8.2.4.32 Removal and refitting of instrument panel right lower bottom plate assembly](#))

4. Remove the central control box of cabin.

a. Unscrew 4 fixing bolts of the cabin central control box.

Tightening torque of bolt: $6\pm 1\text{Nm}$.

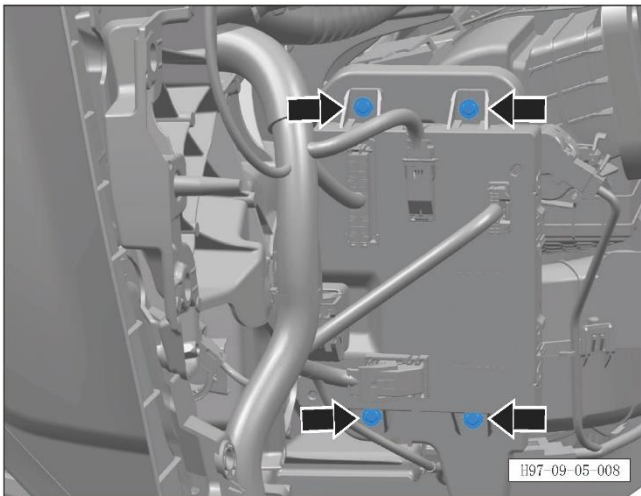

b. Disconnect 5 connectors of the cabin central control box.

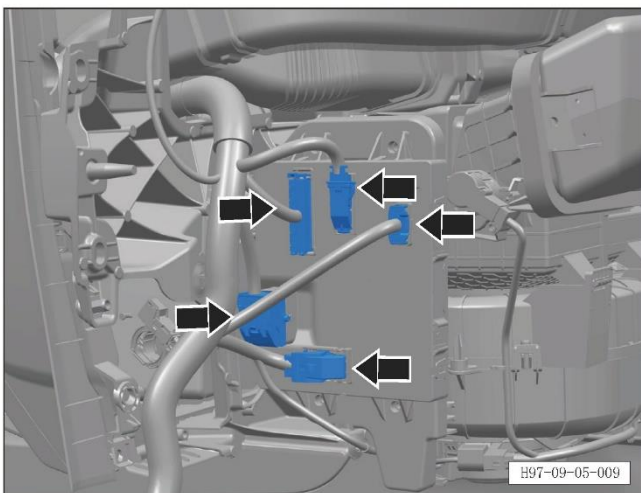

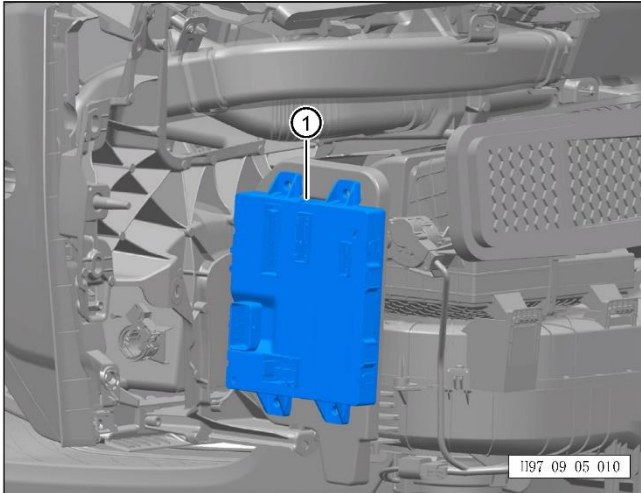

c. Remove the cabin central control box ①.

Refitting procedure

The refitting procedure is performed in reverse order.

9.5.7.2 Removal and refitting of cabin central control box bracket

Removal procedure

1. Turn off all electrical appliances and the start switch.
2. Disconnect the negative terminal of the battery (refer to [3.1.7.1 Maintenance and inspection of battery](#))
3. Remove the instrument panel assembly (refer to [8.2.4.37 Removal and refitting of instrument panel assembly](#))
4. Remove the cabin central control box (refer to [9.5.7.1 Removal and refitting of cabin central control box](#))
5. Remove the cabin central control box bracket.

- a. Unscrew 3 fixing bolts of the cabin central control box bracket.

Tightening torque of bolt: $6\pm 1\text{Nm}$.

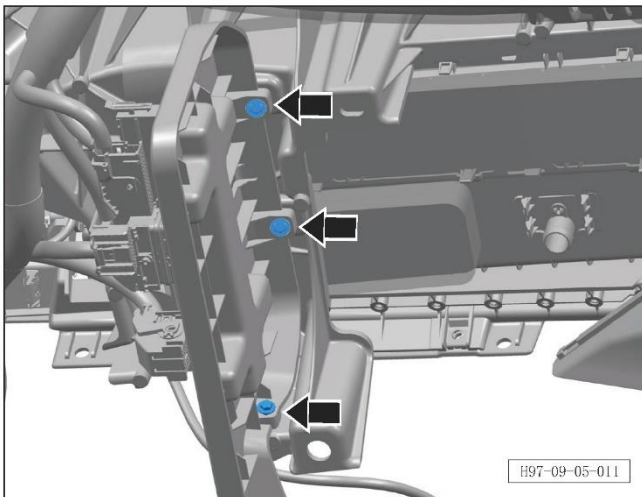

- b. Remove the cabin central control box bracket ①.

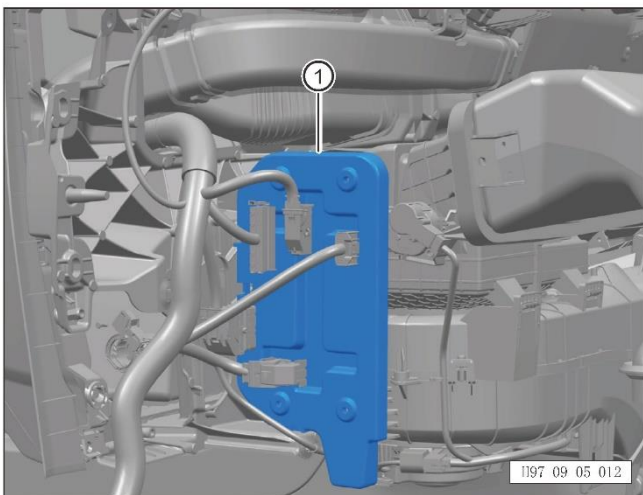

Refitting procedure

The refitting procedure is performed in reverse order.

9.5.8 Hidden handle control

9.5.8.1 Removal and refitting of left front door hidden handle control unit

Removal procedure

Note:

- The following is the removal and refitting of the left front door hidden handle control unit, which can be referred to for the operations on the right front door and rear door.

1. Turn off all electrical appliances and the start switch.
2. Disconnect the negative terminal of the battery (refer to [3.1.7.1 Maintenance and inspection of battery](#))
3. Remove the left front door trim panel assembly (refer to [8.4.2.1 Removal and refitting of front door trim panel assembly](#))
- 4 Remove the left front door hidden handle control unit.

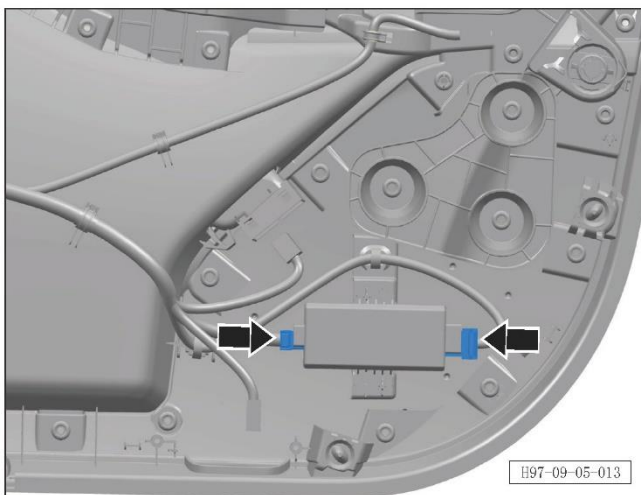

- a. Disconnect 2 connectors of the left front door hidden handle control unit.

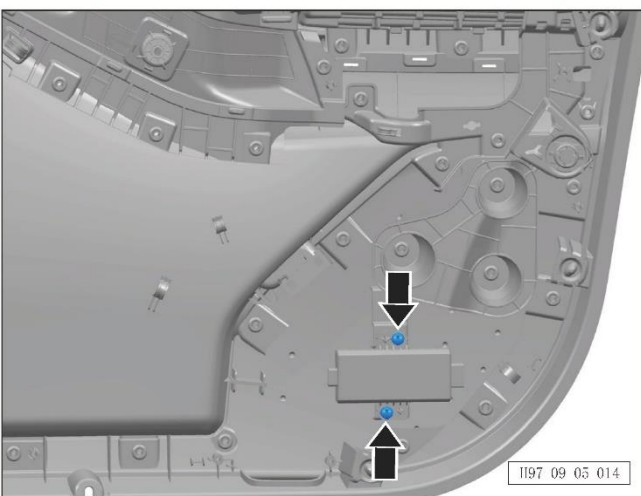

- b. Unscrew 2 fixing screws of the left front door hidden handle control unit.

Tightening torque of screw: $1.5 \pm 0.5 \text{ Nm}$

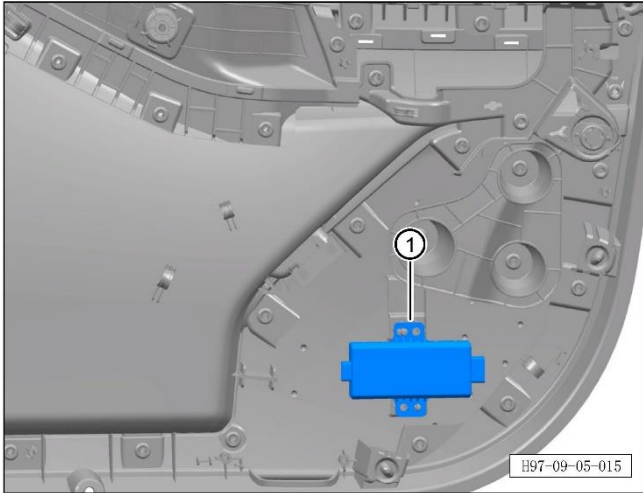

c. Remove the left front door hidden handle control unit ①.

Refitting procedure

The refitting procedure is performed in reverse order.

9.5.9 ETC T-box

9.5.9.1 Removal and refitting of ETC

Removal procedure

1. Turn off all electrical appliances and the start switch.
2. Disconnect the negative terminal of the battery (refer to [3.1.7.1 Maintenance and inspection of battery](#))
3. Remove the interior rearview mirror front trim cover (refer to [8.6.8.7 Removal and refitting of interior rearview mirror front trim cover](#))
4. Remove the rear trim cover of interior rearview mirror (refer to [8.6.8.9 Removal and refitting of rear trim cover of interior rearview mirror](#))
5. Remove the ETC.

- a. Disconnect the connector of the ETC to remove the ETC ①.

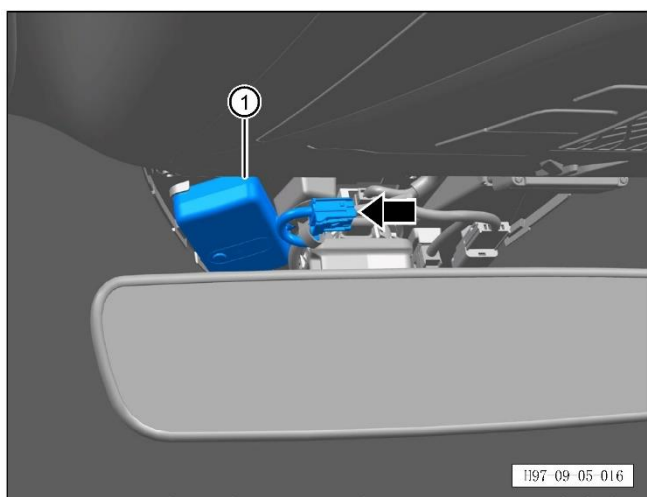

Refitting procedure

The refitting procedure is performed in reverse order.

9.5.10 Rain/light sensing device

9.5.10.1 Removal and refitting of rain/light sensor

Removal procedure

1. Turn off all electrical appliances and the start switch.
2. Disconnect the negative terminal of the battery (refer to [3.1.7.1 Maintenance and inspection of battery](#))
3. Remove the interior rearview mirror front trim cover (refer to [8.6.8.7 Removal and refitting of interior rearview mirror front trim cover](#))
4. Remove the rear trim cover of interior rearview mirror (refer to [8.6.8.9 Removal and refitting of rear trim cover of interior rearview mirror](#))
5. Remove the interior rearview mirror assembly (refer to [8.6.8.10 Removal and refitting of interior rearview mirror assembly](#))
6. Remove the rain/light sensor.

- a. Disengage 2 fixing clips of the rain/light sensor.

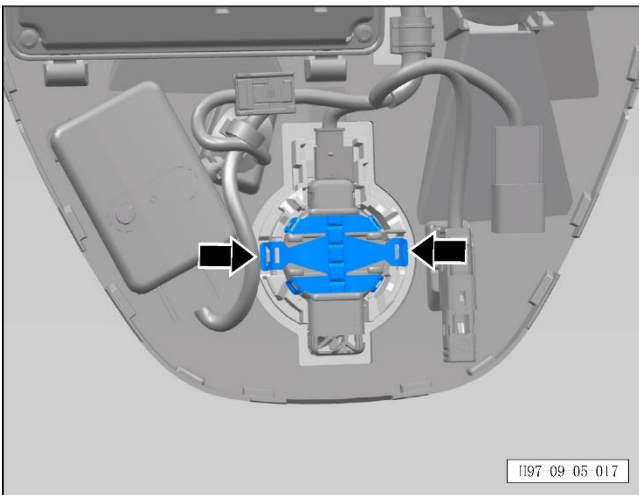

- b. Disconnect the connector of the rain/light sensor to remove the ETC ①.

CAUTION:

- Care shall be taken to avoid damage to the coating.
- Remove the adhesive residues from the interior rearview mirror positioning plate with a wire brush.
- Use a glass scraper to scrape off the adhesive residues on the front windshield to reveal the coating.
- Clean the glued surfaces with a cleaning agent.

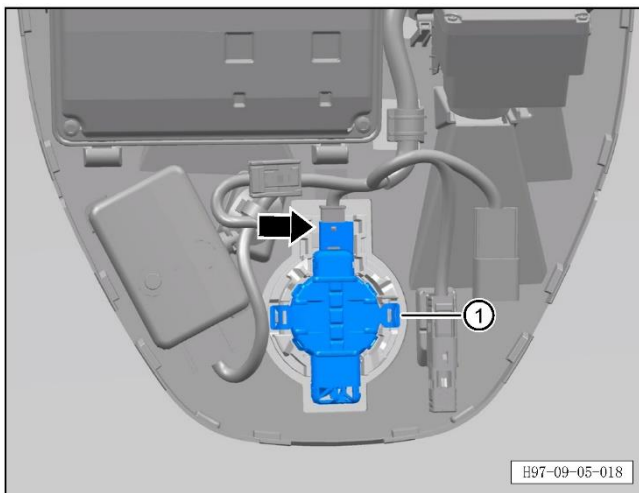

Refitting procedure

The refitting procedure is performed in reverse order.

CAUTION:

- Apply the adhesive evenly to the interior rearview mirror positioning plate, wait 30 s, press it firmly (but not too hard) against the front windshield and hold for 15 s.
- Wipe off excessive adhesive with a rag.
- The interior rearview mirror assembly can be refitted after 15 minutes.

9.6 Electric control system

9.6.1 Window regulator control device

9.6.1.1 Description and operation

System description

The power window system of this model consists of BCM, window regulator motors for the front and rear four doors, window regulator switches for the front and rear four doors, front passenger/rear window button prohibition switches, and smart remote keys. All power windows can be operated accordingly via the relevant window regulator switch or smart remote key.

Window regulator initialization

If it is found that the power window does not have a one-key lifting function, the anti-pinch function fails or is triggered several times in a short period which causes the automatic failure of the initialization state, the initialization operation needs to be performed again in all the above situations.

1. Lift the corresponding window button to raise it until the window is raised to half position, then release the button;
2. After holding for 3 s, continue with step 1 until the glass no longer rises;
3. Hold the action of step 2 for 3 s and then release the window button to complete the window initialization;
4. If the window still has no automatic lifting/lowering function, please repeat the above steps.

9.6.1.2 Position diagram of parts

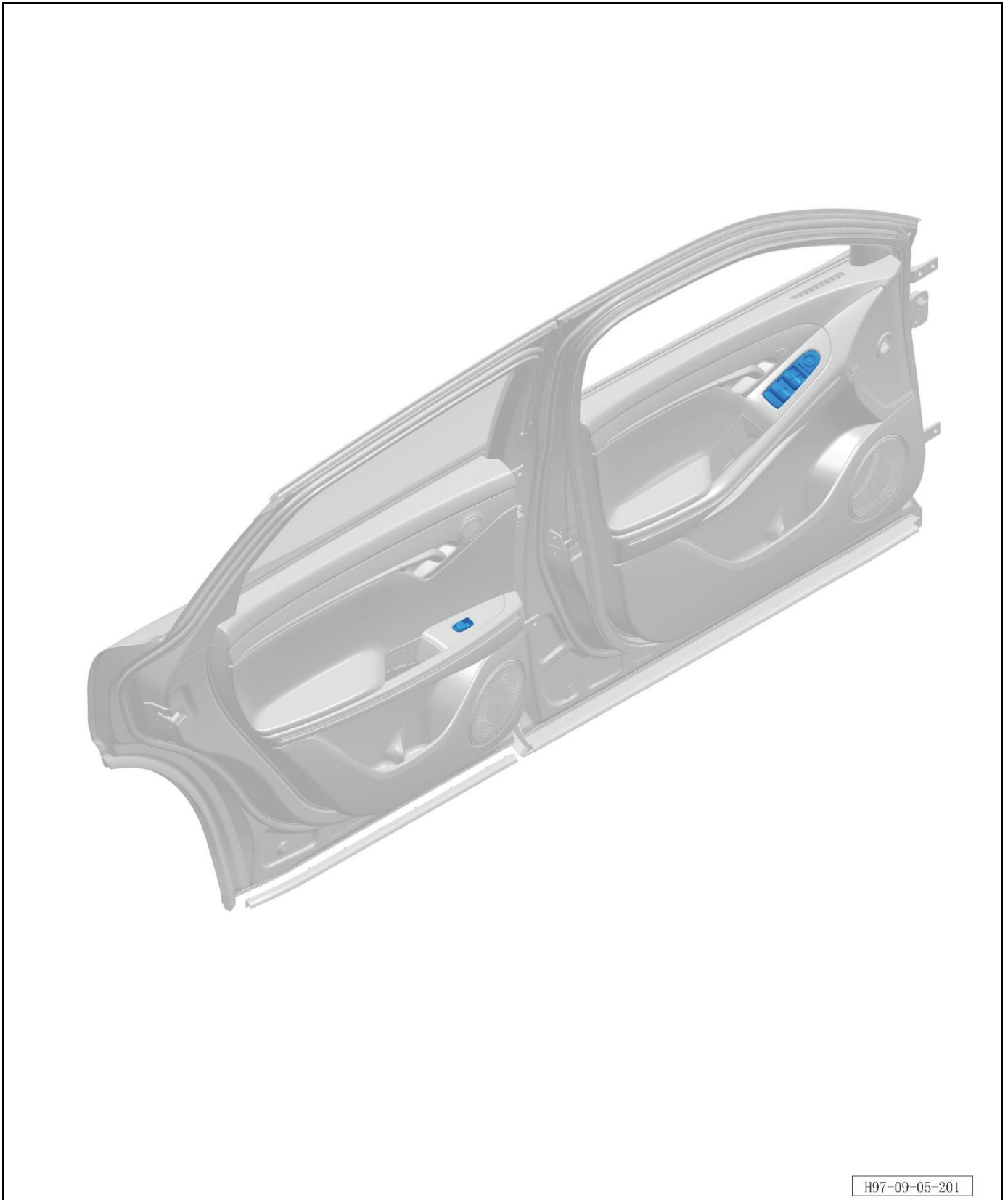

9.6.1.3 Electrical schematic diagram

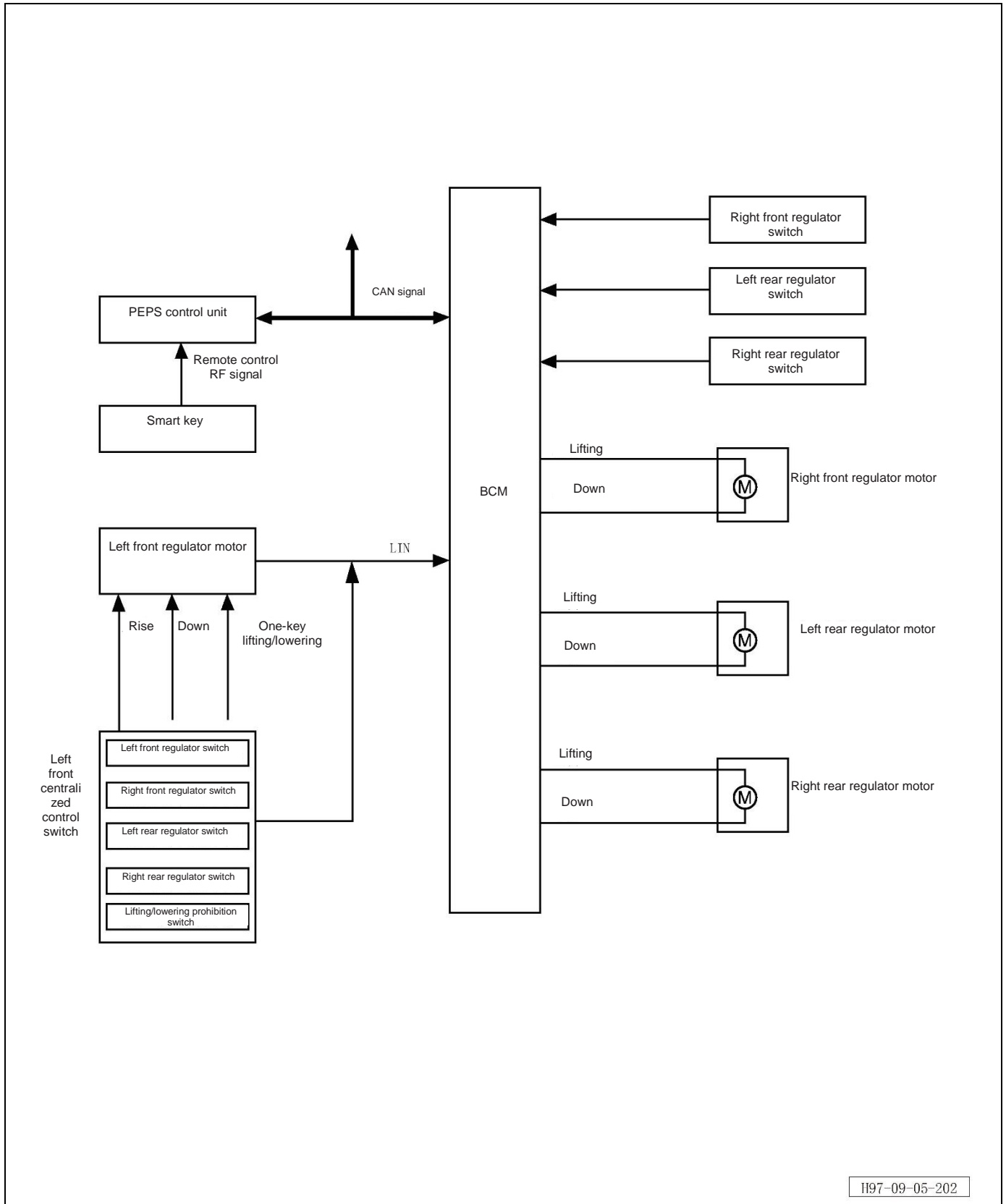

9.6.1.4 Removal and refitting of left front power window switch

Removal procedure

1. Turn off all electrical appliances and the start switch.
2. Disconnect the negative terminal of the battery (refer to [3.1.7.1 Maintenance and inspection of battery](#))
3. Remove the left front door trim panel assembly (refer to [8.4.2.1 Removal and refitting of front door trim panel assembly](#))
4. Remove the left front door power window switch.
 - a. Disconnect the connector of the left front door power window switch.

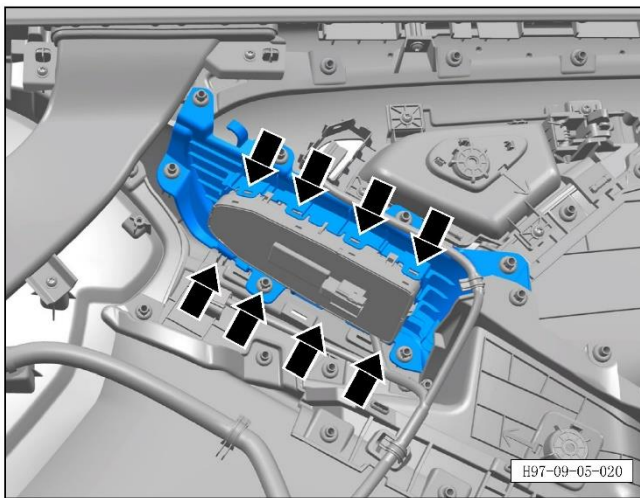
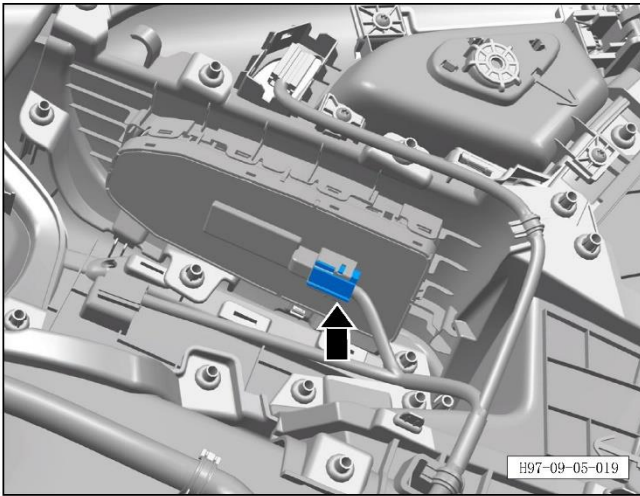

- b. Disengage 8 fixing clips on both sides of the left front door power window switch.

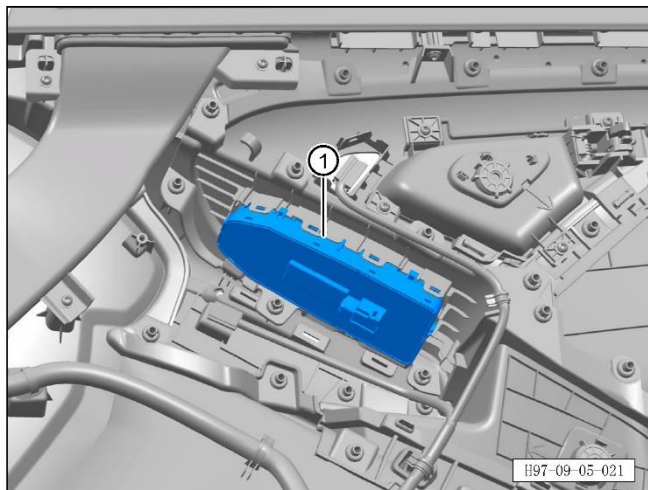

c. Remove the left front door power window switch ①.

Refitting procedure

The refitting procedure is performed in reverse order.

9.6.1.5 Removal and refitting of right front power window switch

Removal procedure

Note:

- The following is the removal and refitting of the right front door power window switch, which can be referred to for the operations on the rear door.

1. Turn off all electrical appliances and the start switch.
2. Disconnect the negative terminal of the battery (refer to [3.1.7.1 Maintenance and inspection of battery](#))
3. Remove the right front door trim panel assembly (refer to [8.4.2.1 Removal and refitting of front door trim panel assembly](#))
4. Remove the right front door power window switch.

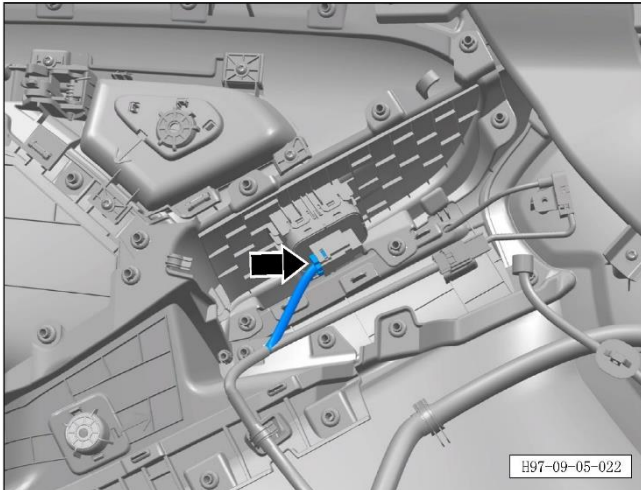

a. Disconnect the connector of the right front door power window switch.

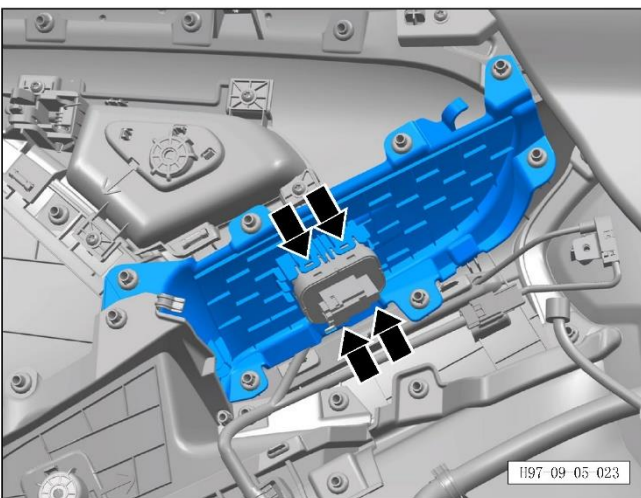

b. Disengage 4 fixing clips on both sides of the right front door power window switch.

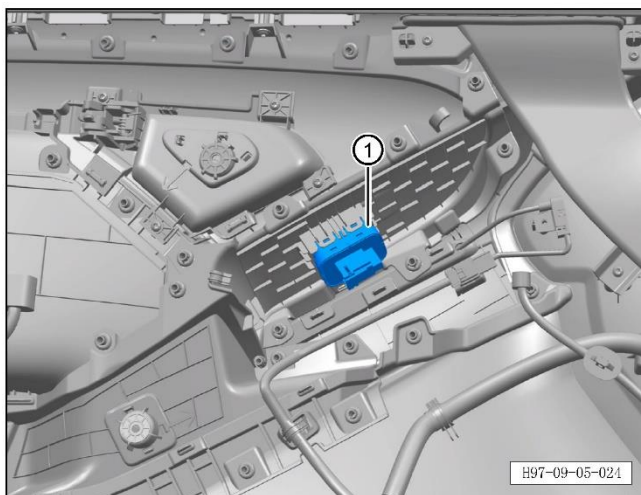

c. Remove the right front door power window switch ①.

Refitting procedure

The refitting procedure is performed in reverse order.

9.6.2 Central lock control device

9.6.2.1 Description and operation

The central lock system is mainly composed of BCM, PEPS, smart remote key, locks of the front and rear four doors, and tailgate locks. All locking and unlocking can be operated correspondingly via the PEPS, the smart key remote control, the central lock switch or the mechanical key.

Operating instructions:

1. Unlock/lock the four door and tailgate locks with the smart remote key.
2. Unlock/lock the four door and tailgate locks with the Bluetooth key.
3. Unlock/lock the four door and tailgate locks through the central lock switch.
4. Unlock/lock the tailgate with the tailgate switch.

9.6.2.2 Position diagram of parts



9.6.2.3 Electrical schematic diagram

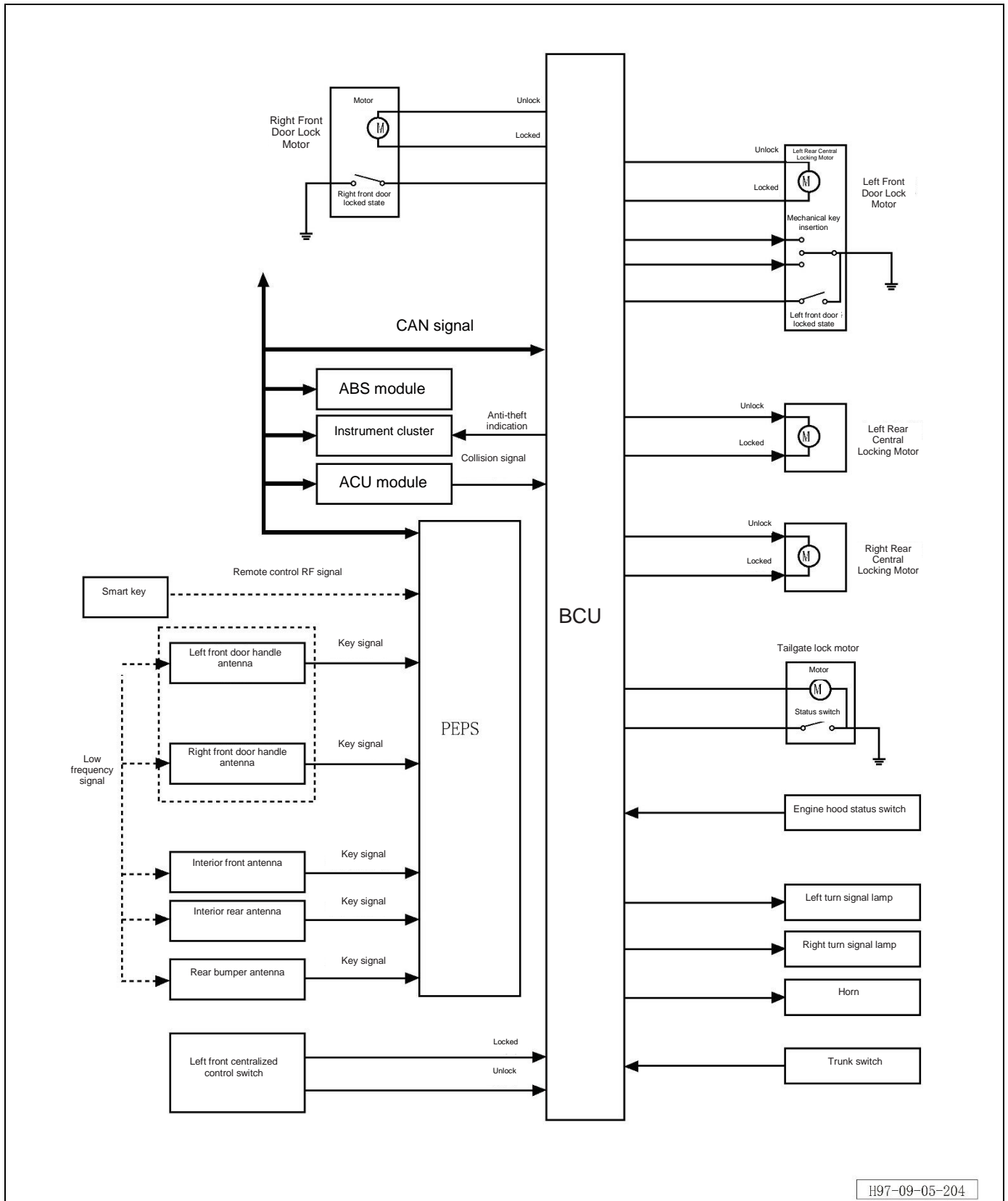

9.6.2.4 Removal and refitting of central lock switch

Removal procedure

1. Turn off all electrical appliances and the start switch.
2. Disconnect the negative terminal of the battery (refer to [3.1.7.1 Maintenance and inspection of battery](#))
3. Remove the left front door trim panel assembly (refer to [8.4.2.1 Removal and refitting of front door trim panel assembly](#))
4. Remove the central lock switch.
 - a. Disconnect the connector of the central lock switch.

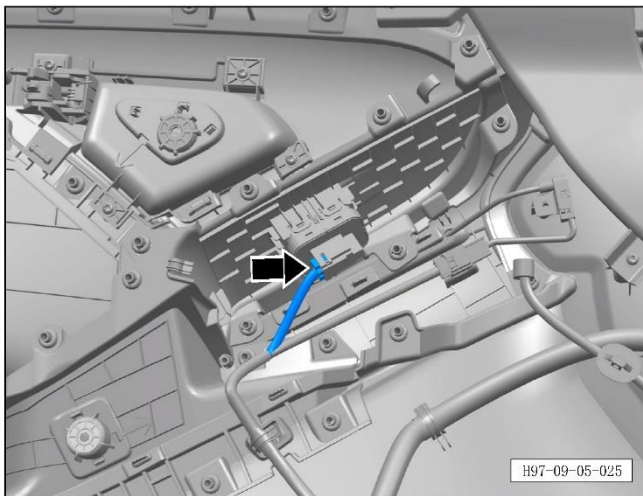

- b. Disengage 4 fixing clips of the central lock switch to remove the central lock switch ①.

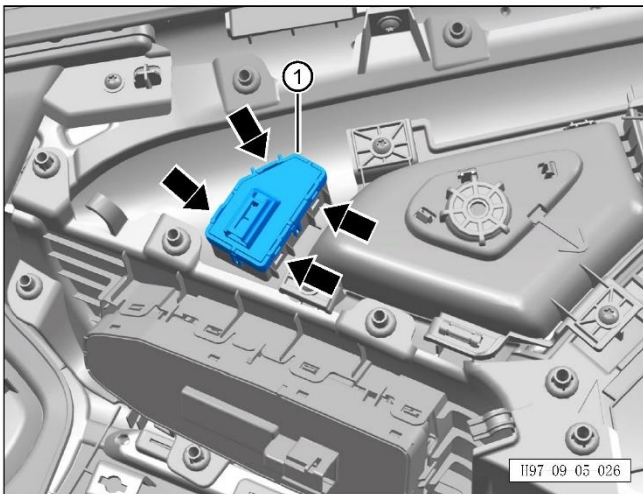

Refitting procedure

The refitting procedure is performed in reverse order.

9.6.3 Start/stop control device

9.6.3.1 Description and operation

Start the vehicle

The driver enters the vehicle with the smart key:

1. Confirm that the gear is in P or N;
2. Depress the brake pedal to the bottom and keep it in this position to ensure that the "START/STOP" button indicator is illuminated;
3. Press the "START/STOP" button for 2 s, and when the "READY" indicator is illuminated, start the vehicle.

When the vehicle gear is in P or N and the brake pedal is not depressed, press the engine start/stop button and it will switch in the order of START-STOP:

-START: the switch indicator and the instrument lamp are illuminated, and all electrical equipment circuits are connected;

-STOP: the switch indicator goes out and the engine start/stop button is turned off. Vehicle emergency start

When the smart key cannot start the vehicle due to lack of power, you can place the smart key on the emergency start mark on the storage box pad of the console, press the engine start/stop button at the same time, and depress the brake pedal, and the engine start/stop button indicator will turn green; then press the engine start/stop button again to start the vehicle.

CAUTION!

- When the battery of the smart key is low, press the engine start/stop button, then the display of the instrument cluster will prompt "Low power of key, please replace the smart key as soon as possible".

Turn off the vehicle

1. Stop the vehicle stably and apply the EPB;
2. Switch to P position;
3. Press the engine start/stop button to turn off the vehicle.

9.6.3.2 Removal and refitting of engine start/stop button

Removal procedure

1. Turn off all electrical appliances and the start switch.
2. Disconnect the negative terminal of the battery (refer to [3.1.7.1 Maintenance and inspection of battery](#))
3. Remove the middle protective plate assembly (refer to [8.2.4.21 Removal and refitting of middle protective plate assembly](#))
4. Remove the engine start/stop button.
 - a. Disconnect the connector of the engine start/stop button and disengage its 2 fixing clips.

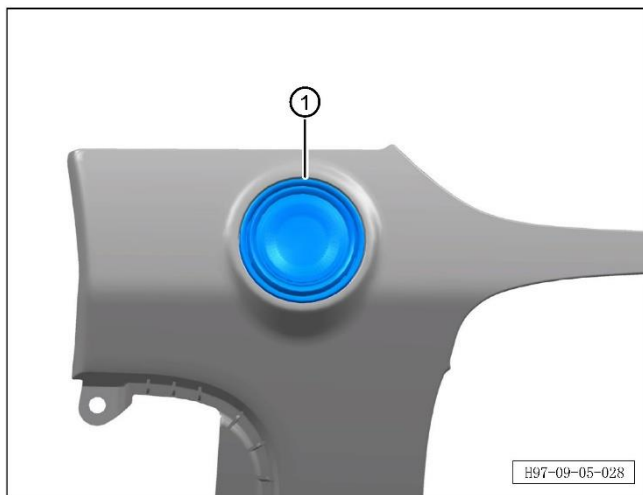
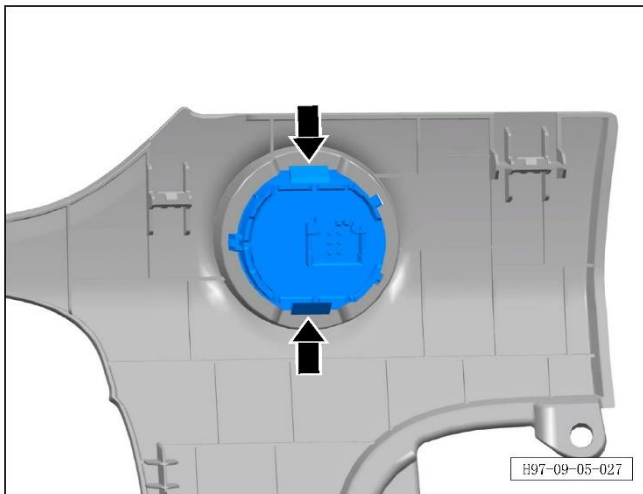

- b. Remove the engine start/stop button ①.

Refitting procedure

The refitting procedure is performed in reverse order.

9.6.4 A/C control device

9.6.4.1 Description and operation

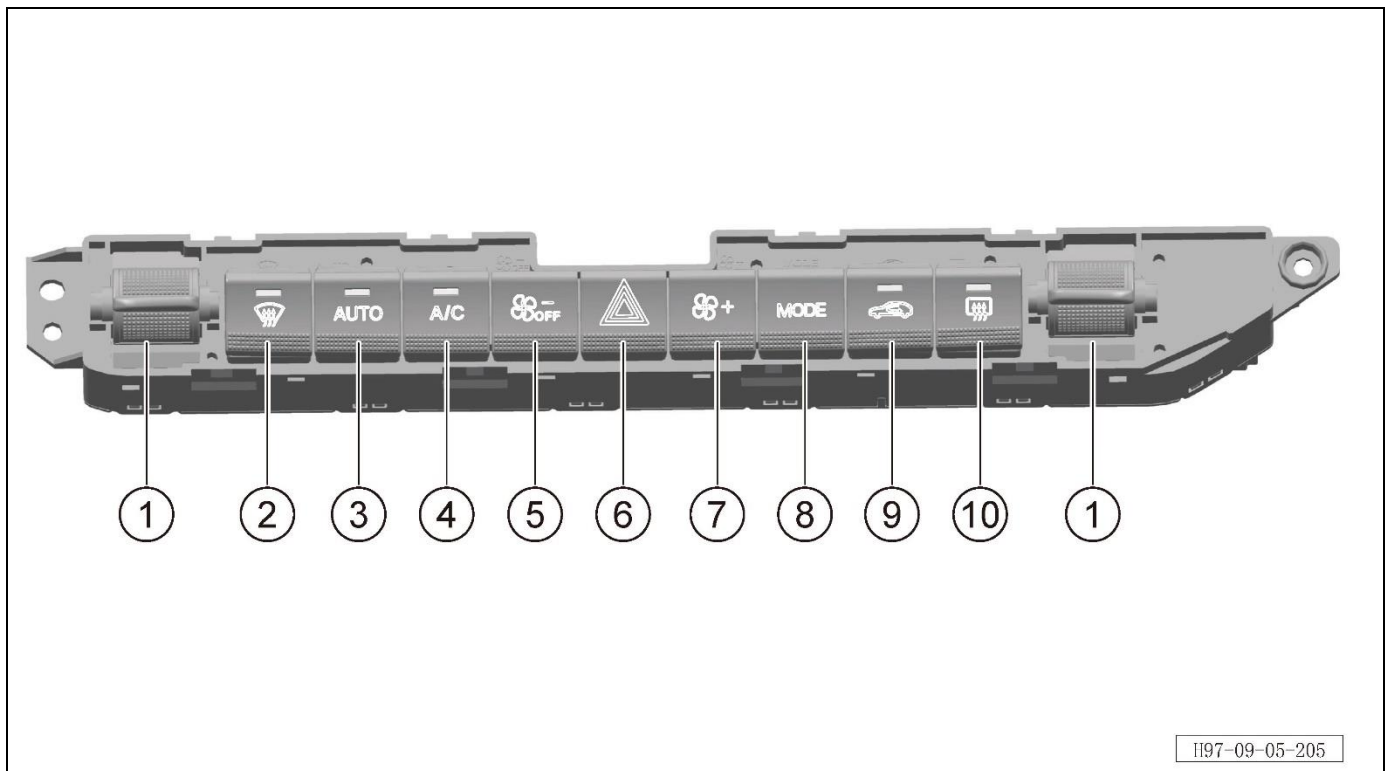

S/N	Key name	Key function
1	Temperature control	Press the up/down button to raise or lower the temperature, and the temperature can be adjusted by 0.5°C each time
2	Front windshield defrosting	Press the button, then the button lamp will be illuminated, and the front windshield defrosting function will be turned on.
3	AUTO gear	Press the button, then the button lamp will be illuminated, and the A/C system will be in automatic mode.
4	AC switch	Press the button, the button lamp will be illuminated, and the A/C system will begin to refrigerate.
5	Air volume -	Press the button, then the wind speed will be reduced by one level
6	Hazard alarm switch	In case of vehicle failure or risky situations
7	Air volume +	Press the button, then the wind speed will be increased by one level
8	Mode selection	Outlet mode circulation switch
9	Circulation mode	Press the button, then the air circulation will be automatically switched between automatic internal and external circulation, internal circulation and external circulation
10	Rear windshield defogging	Press the button, the button lamp will be illuminated, the rear windshield defrosting function will be turned on, and the rear windshield and exterior rearview mirrors will be electrically heated.

9.6.4.2 Removal and refitting of automatic A/C control panel

Removal procedure

1. Turn off all electrical appliances and the start switch.
2. Disconnect the negative terminal of the battery (refer to [3.1.7.1 Maintenance and inspection of battery](#))
3. Remove the rear trim strip assembly (refer to [8.2.4.1 Removal and refitting of rear trim strip assembly](#))
4. Remove the automatic A/C control panel.

- a. Unscrew 2 fixing screws of the automatic A/C control panel.

Tightening torque of screw: $2.0 \pm 0.5 \text{ Nm}$

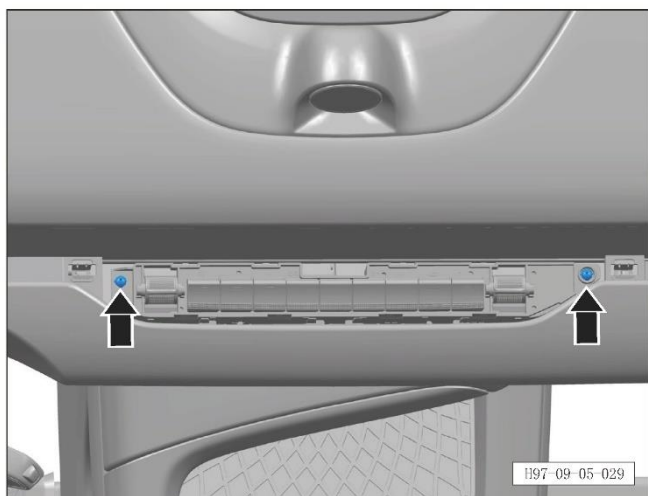

- b. Disconnect the connector of the automatic A/C control panel to remove the automatic A/C control panel ①.

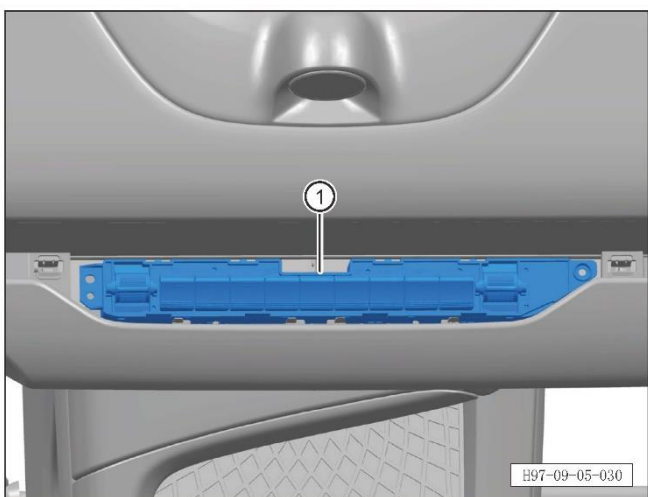

Refitting procedure

The refitting procedure is performed in reverse order.

9.6.5 Touch control device

9.6.5.1 Description and operation

The touchpad is located on the right side of the console, and is mainly used to identify various gesture information and convert the corresponding gesture information into corresponding functional responses. The following functions can be achieved by operating the touchpad:

Category	Gesture signal	Corresponding functions	Remarks
One-finger operation	One-finger click		Customizable
	Swipe from left to right with one finger	Next track	
	Swipe from right to left with one finger	Last track	
	Swipe down with one finger	Volume -	
	Swipe up with one finger	Volume +	
	Twice clicking with one finger	Audio mode switch	
	Swipe left and right at the edge with one finger		Customizable
	Swipe around with one finger (clockwise/counterclockwise)		Customizable

Category	Gesture signal	Corresponding functions	Remarks
Two-finger operation	Swipe from right to left with two fingers	Move the map to the left	
	Swipe from left to right with two fingers	Move the map to the right	
	Swipe up with two fingers	Move the map up	
	Swipe down with two fingers	Move the map down	
	Zoom in with two fingers	Full screen map zoom in	
	Zoom out with two fingers	Full screen map zoom out	
	Swipe left and right at the edge with two fingers		Customizable
	Swipe in a circle with two fingers (clockwise/counterclockwise)		Customizable

Functions can be customized according to actual needs, such as: closing the screen, changing the screen, starting the rear monitoring, starting the recording, switching the instrument style, etc.

9.6.5.2 Removal and refitting of touchpad

Removal procedure

1. Turn off all electrical appliances and the start switch.
2. Disconnect the negative terminal of the battery (refer to [3.1.7.1 Maintenance and inspection of battery](#))
3. Remove the upper panel assembly (refer to [8.3.4.2 Removal and refitting of upper panel assembly](#))
4. Remove the touchpad.

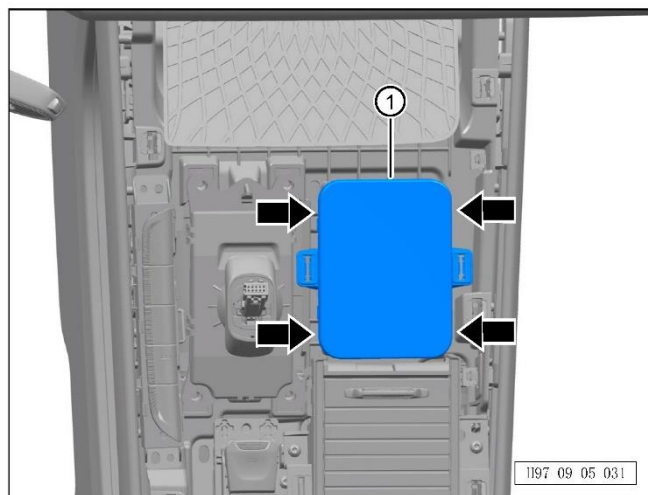

- a. Disconnect 4 fixing clips of at the bottom of the touchpad.
- b. Disconnect the connector of the touchpad to remove the touchpad ①.

Refitting procedure

The refitting procedure is performed in reverse order.

9.6.6 Multifunction combination control device

9.6.6.1 Description and operation

Description of the combination switch on the console:

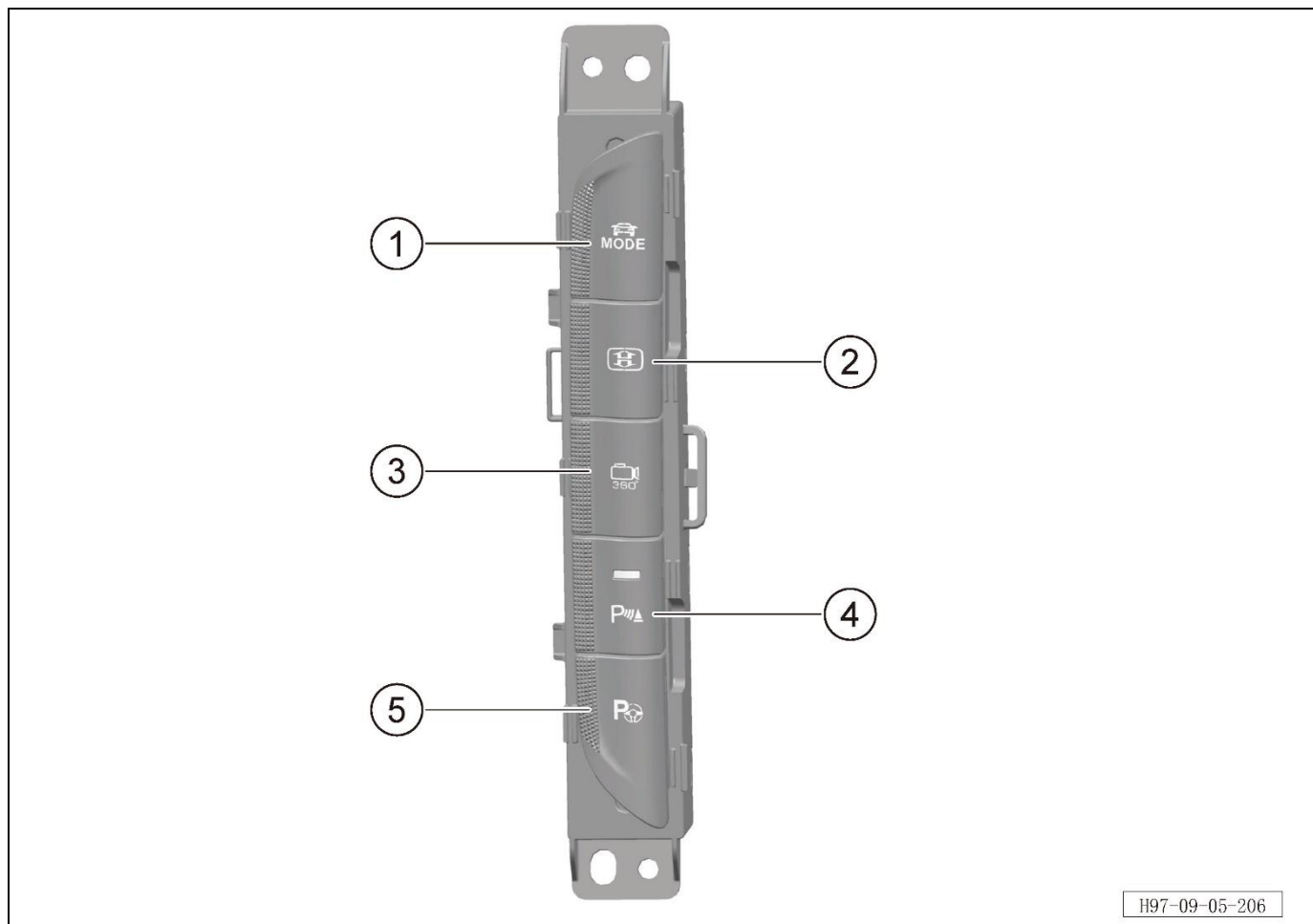

S/N	Key name	Key function
1	Driving Mode	Quickly switch the driving modes
2	Triple screen lifting/lowering	Press the button, then the triple screen will be lifted/lowered
3	AVM system	Press the button, then the AVM system will be turned on/off
4	Rear corner radar system	Press the button, then the rear corner radar system will be turned on/off
5	APA	Press the button then the APA will be turned on/off

Description of steering column switch assembly:

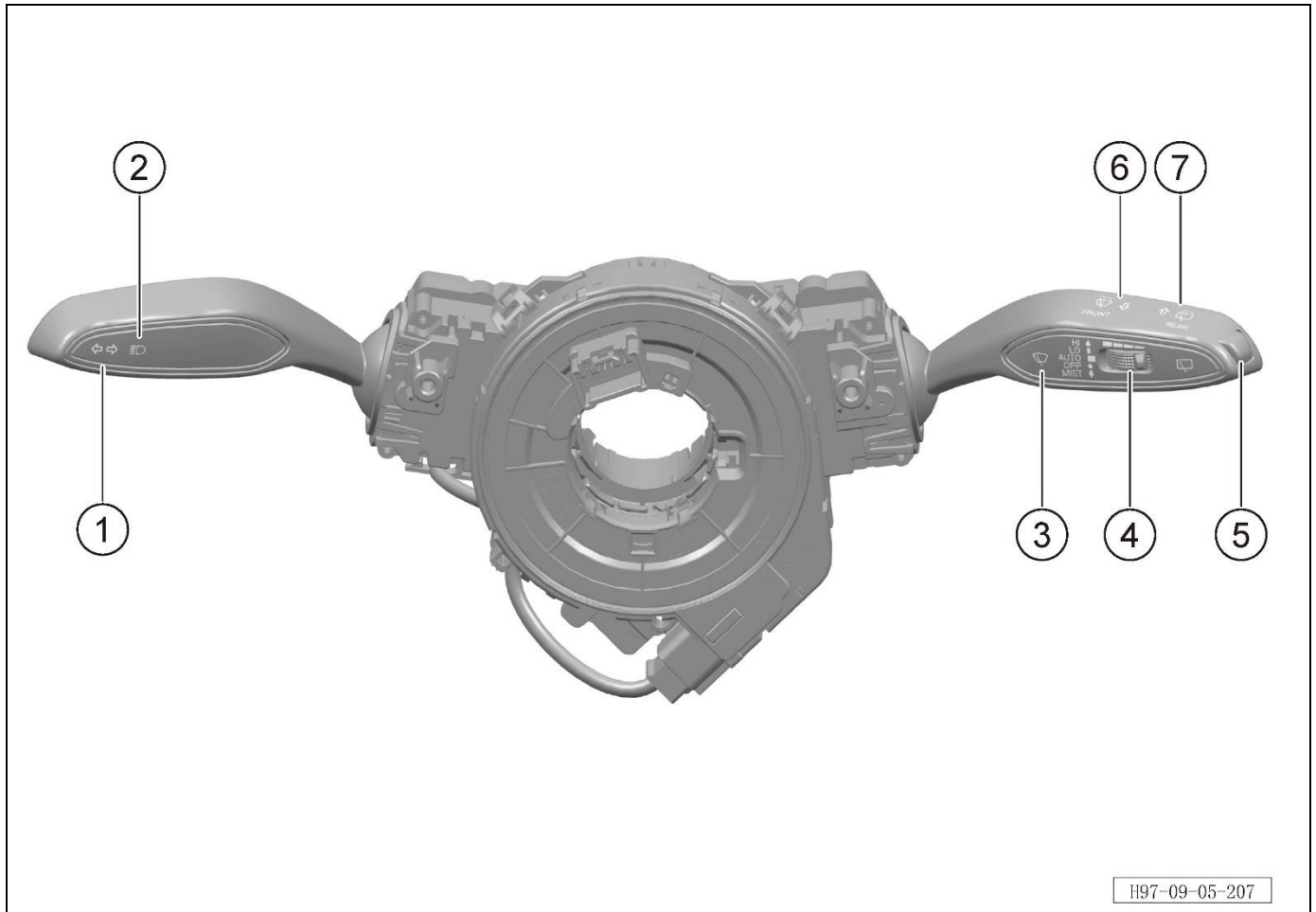

S/N	Key name	Key function
1	Turn signal lamp	When the lamp control lever is moved down, the left turn signal will be turned on; When the lamp control lever is moved up, the right turn signal will be turned on
2	High beam	Move the lamp control lever outward/inward to turn on/off the high beams
3	HI	Fast wiping
	LO	Slow wiping
	AUTO	Automatic wiping
	OFF	Turn off the front windshield wiping
	MIST	Single wiping
4	Automatic wiper	Adjustment of automatic wiper sensitivity
5	Rear wiper	Turn on/off the rear wiper
6	Front windshield washer	Turn on/off the front windshield washer
7	Rear window washer	Turn on/off the rear windshield washer

Description of lamp switch:

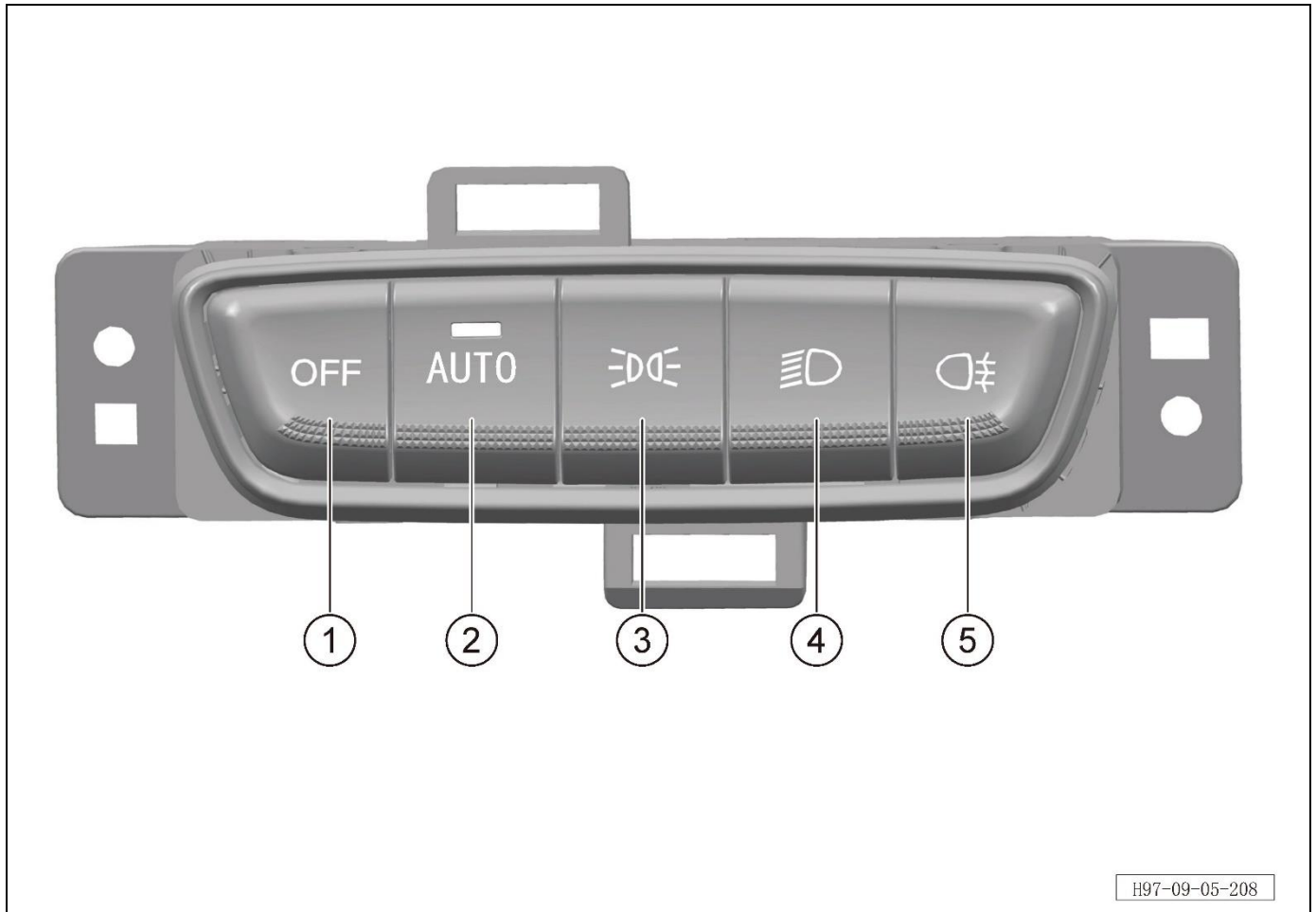

S/N	Key name	Key function
1	Combination lamp	Press the button, then the combination lamps will be turned on/off.
2	Automatic lamp	Press the button, then the automatic lamp functions will be turned on/off.
3	Position lamp	Press the button, then the position lamp will be turned on/off.
4	Low beam	Press the button, then the low beam will be turned on/off.
5	Rear fog lamp	Press the button, then the rear fog lamp will be turned on/off.

9.6.6.2 Removal and refitting of console combination switch

Removal procedure

1. Turn off all electrical appliances and the start switch.
2. Disconnect the negative terminal of the battery (refer to [3.1.7.1 Maintenance and inspection of battery](#))
3. Remove the upper panel assembly (refer to [8.3.4.2 Removal and refitting of upper panel assembly](#))
4. Remove the console combination switch.



- a. Unscrew 2 fixing screws of the console combination switch.

Tightening torque of screw: $1.5 \pm 0.5 \text{ Nm}$



- b. Disconnect the connector of the console combination switch to remove the console combination switch ①.

Refitting procedure

The refitting procedure is performed in reverse order.

9.6.6.3 Removal and refitting of steering column switch assembly

Removal procedure

CAUTION:

- When removing the steering column switch assembly, fix the clock spring first and do not turn it at will.

1. Turn off all electrical appliances and the start switch.
2. Disconnect the negative terminal of the battery (refer to [3.1.7.1 Maintenance and inspection of battery](#))
3. Remove the steering wheel (refer to [10.2.3.1 Removal and refitting of steering wheel assembly](#))
4. Remove the steering column upper shield assembly (refer to [8.2.4.15 Removal and refitting of steering column upper shield assembly](#))
5. Remove the steering column lower shield assembly (refer to [8.2.4.16 Removal and refitting of steering column lower shield assembly](#))
6. Remove the steering column switch assembly.

a. Disconnect the connector of the steering column switch assembly.

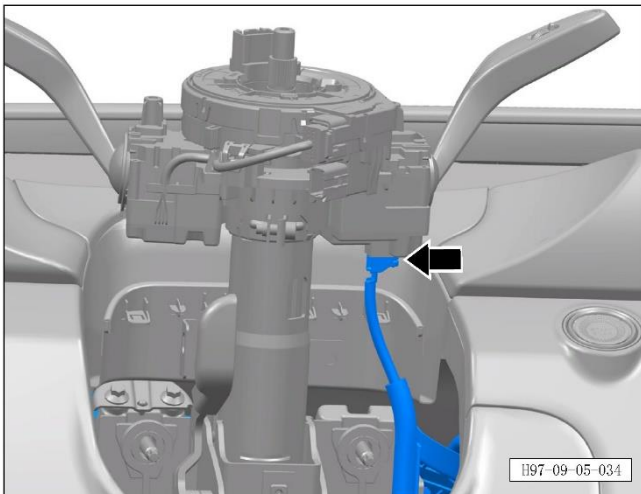

b. Loosen the clamp of the steering column switch assembly.

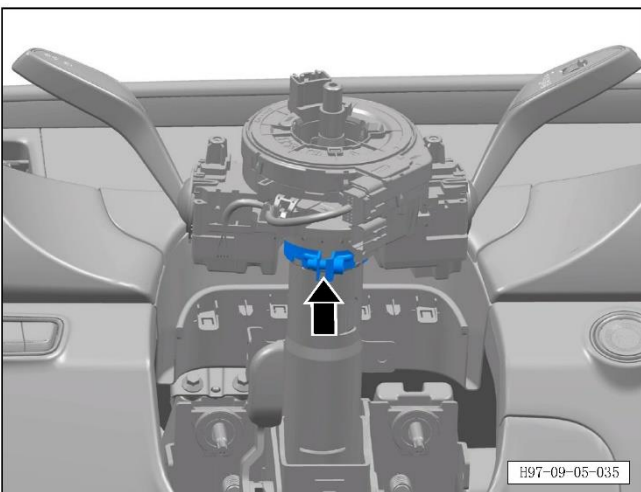

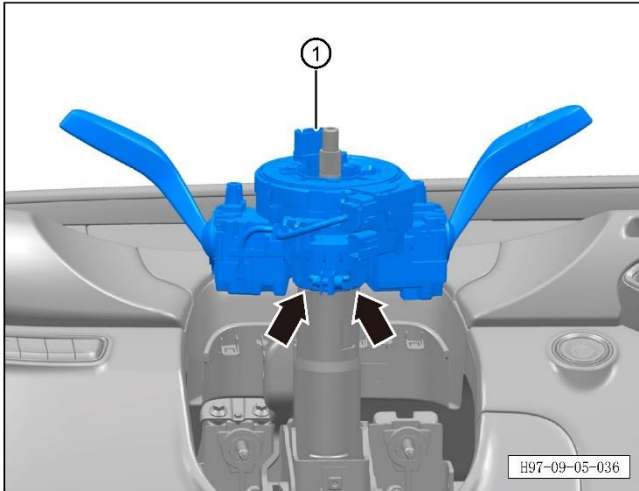

c. Disengage 2 fixing clips of the steering column switch assembly to remove the steering column switch assembly ①.

Refitting procedure

The refitting procedure is performed in reverse order.

9.6.6.4 Removal and refitting of clock spring

Removal procedure

1. Turn off all electrical appliances and the start switch.
2. Disconnect the negative terminal of the battery (refer to [3.1.7.1 Maintenance and inspection of battery](#))
3. Remove the steering wheel (refer to [10.2.3.1 Removal and refitting of steering wheel assembly](#))
4. Remove the steering column upper shield assembly (refer to [8.2.4.15 Removal and refitting of steering column upper shield assembly](#))
5. Remove the steering column lower shield assembly (refer to [8.2.4.16 Removal and refitting of steering column lower shield assembly](#))
6. Remove the clock spring.

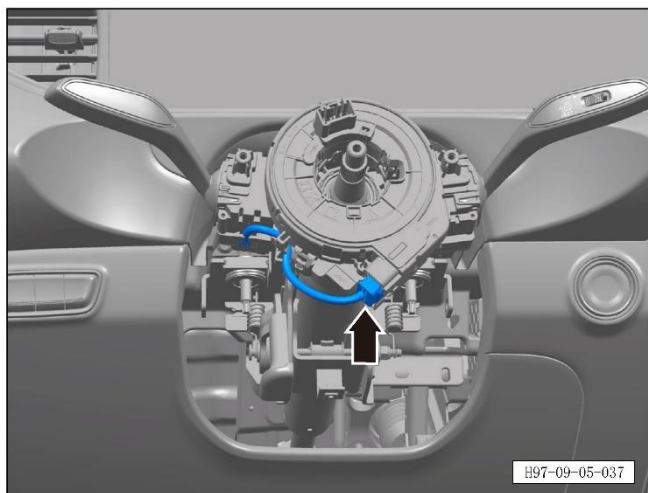

a. Disconnect the connector of the clock spring.

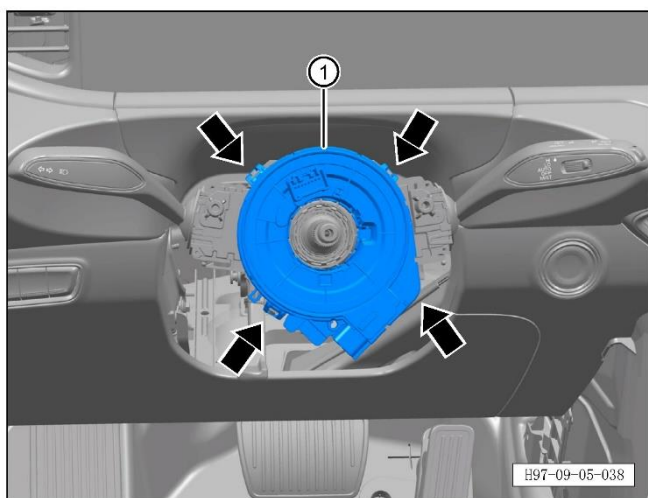

b. Disengage 2 fixing clips of the clock spring to remove the steering column switch assembly ①.

Refitting procedure

The refitting procedure is performed in reverse order.

CAUTION:

- Pay attention to adjusting the clock spring during refitting. If there is any fault, replace the clock spring assembly.

9.6.6.5 Removal and refitting of lamp switch

Removal procedure

1. Turn off all electrical appliances and the start switch.
2. Disconnect the negative terminal of the battery (refer to [3.1.7.1 Maintenance and inspection of battery](#))
3. Remove the left lower guard assembly (refer to [8.2.4.20 Removal and refitting of left lower guard assembly](#))
4. Remove the lamp switch.

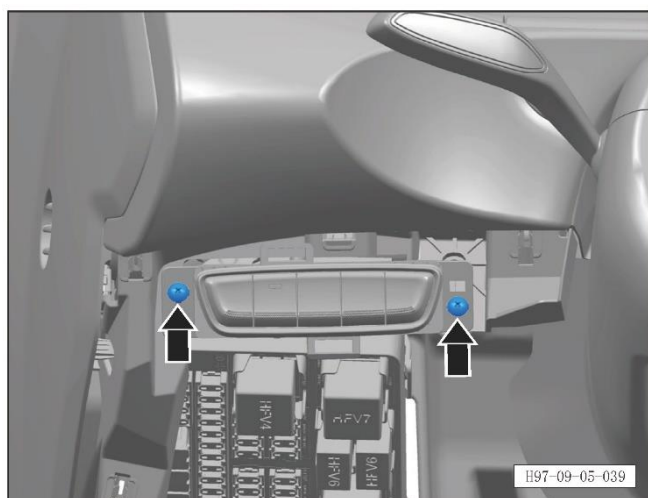

- a. Unscrew 2 fixing screws of the lamp switch.
Tightening torque of screw: $4\pm 1\text{Nm}$

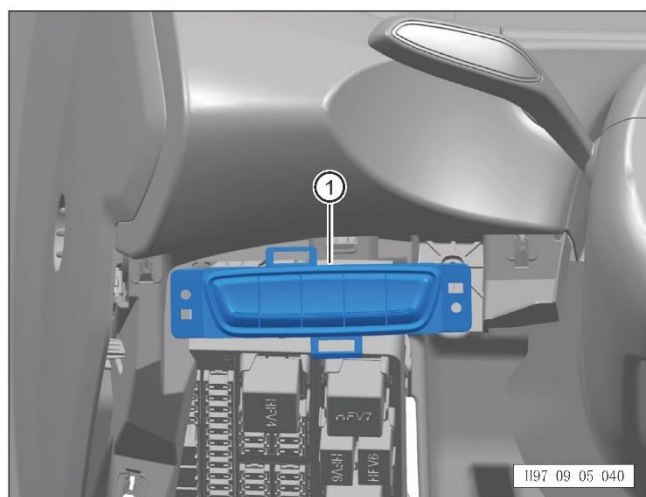

- b. Disconnect the connector of the lamp switch to remove the lamp switch ①.

Refitting procedure

The refitting procedure is performed in reverse order.

9.6.7 Tailgate opening/closing control device

9.6.7.1 Description and operation

Overview of POT system

It controls the tailgate to be electrically opened or closed through switches in the vehicle, behind the vehicle or the remote control key, which is convenient to use. The POT system has the following functions:

a. Anti-pinch

When an obstacle is detected in the electric process, the tailgate will be controlled to reverse or stop for a safe use.

b. Opening height setting

The height of the electric opening can be set, which is convenient for customers of different heights to operate the tailgate in a narrow space.

c. Buzzer reminder

When the tailgate is electrically activated, it will beep to remind customers and surrounding people to make a way for the vehicle.

POT system operation

Driver tailgate switch - it is located on the "left front door assembly" to control the electric opening and closing of the tailgate:

- When the vehicle is stationary, lift the tailgate opening switch on the driver side door to automatically open the tailgate ; Press it to close the tailgate;
- During the electric process of the tailgate, press this switch to stop the tailgate.

The tailgate handle switch only controls the electric opening of the tailgate:

- When the tailgate is stationary, click this switch to electrically open the tailgate;
- During the electric process of the tailgate, click this switch to stop the tailgate.

Tailgate microswitch - it is located on the rear wiper trim panel to control the electric opening and closing of the tailgate:

- When the vehicle is stationary and the tailgate is in the fully closed position, press the microswitch to open the tailgate;
- When the vehicle is stationary and the tailgate is in the open position, press the microswitch to close the tailgate;
- When the vehicle is stationary and the tailgate is opening or closing, press the microswitch to stop the tailgate from moving.

Tailgate closing switch - it is located on the inside of the trunk to control the electric closing of the tailgate:

- When the vehicle is stationary and the tailgate is in the open position, press the tailgate closing switch to close the tailgate;
- During the closing process of the POT, if an obstacle is detected, the anti-pinch function will be triggered, and the tailgate will stop or move in the opposite direction. Large CSD switch:

Click Settings→Vehicle→Body control→Trunk to enter the control interface of the tailgate on which you can control the tailgate and adjust its opening angle.

The tailgate button on the key controls the electric opening and closing of the tailgate:

- When the vehicle is stationary and the tailgate is in the fully closed position, press and hold the tailgate button on the key for 2 s to open the tailgate;
- When the vehicle is stationary and the tailgate is in the open position, press and hold the tailgate button on the key for 2 s to close the tailgate;
- When the vehicle is stationary and the tailgate is opening, press the tailgate opening button to stop opening; Press and hold the tailgate opening button again to close the tailgate.

POT self-learning

The vehicle needs to perform the self-learning of the POT when the new vehicle is rolling off the line and after the vehicle battery is powered on after being powered off.

- After the vehicle battery is powered on for the first time or the battery is powered on after being powered off, press the tailgate opening switch to automatically open the tailgate to the maximum position, and then press the tailgate closing switch after it is stopped to automatically close the tailgate to fully locked position. POT self-learning is completed.

CAUTION!

- Do not push or pull the tailgate manually during the POT self-learning process, because the external force will affect the memory of current and Hall number;

- After the self-learning is completed, the tailgate can be manually opened and closed.

9.6.7.2 Position diagram of parts

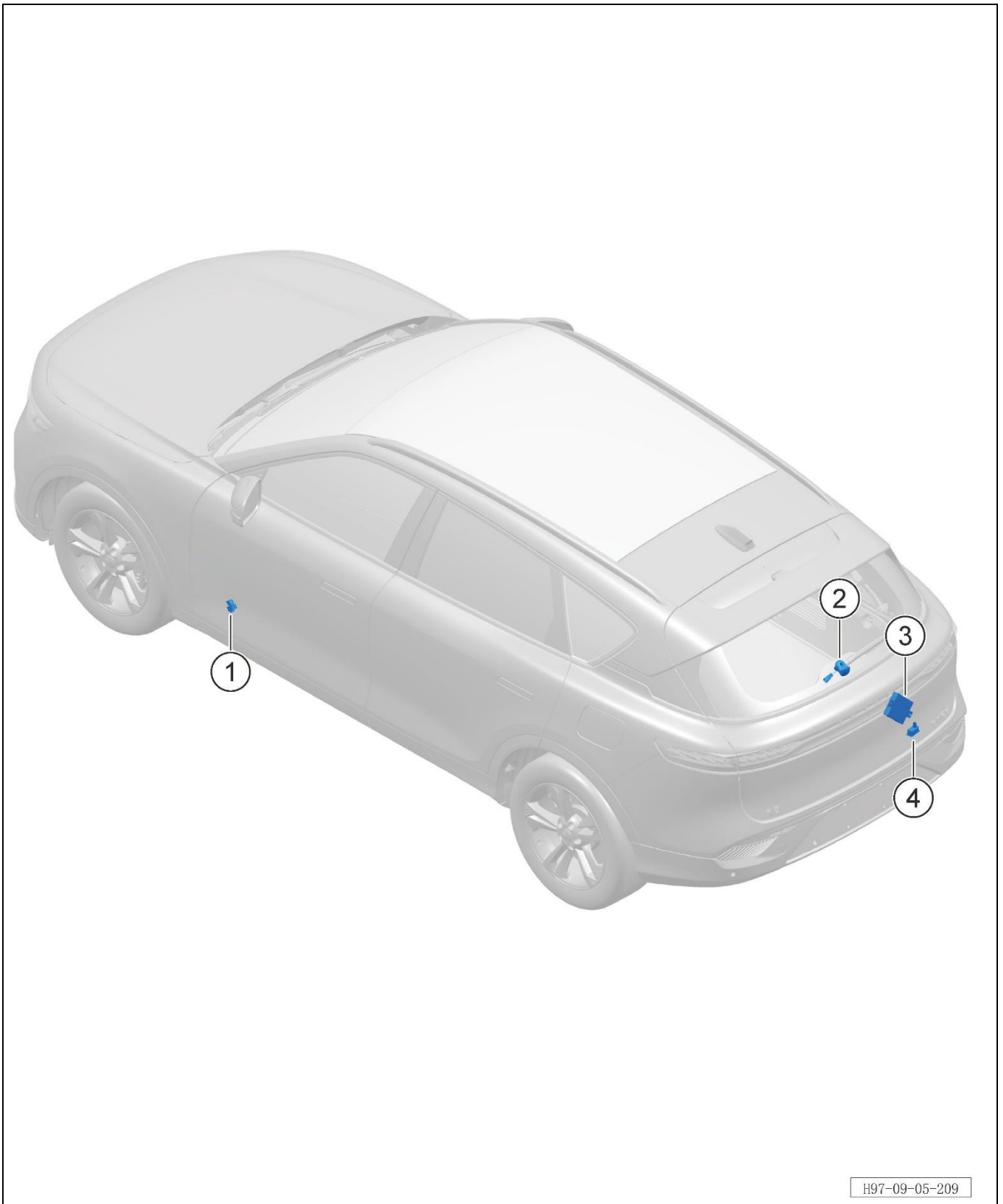

S/N	Part name	Loading quantity	Remarks
1	POT opening/closing switch	1	
2	Trunk lid opening switch	1	
3	POT controller	1	
4	POT closing switch	1	

9.6.7.3 Removal and refitting of POT opening/closing switch

Removal procedure

1. Turn off all electrical appliances and the start switch.
2. Disconnect the negative terminal of the battery (refer to [3.1.7.1 Maintenance and inspection of battery](#))
3. Remove the left front door trim panel assembly (refer to [8.4.2.1 Removal and refitting of front door trim panel assembly](#))
4. Remove the POT opening/closing switch.
 - a. Disconnect the connector of the POT opening/closing switch.

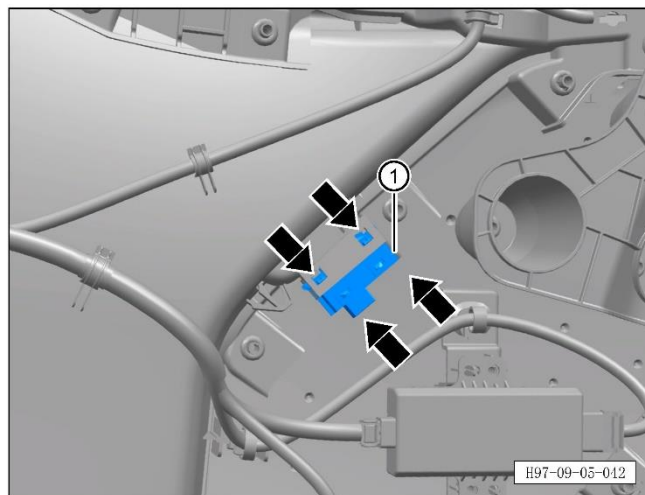
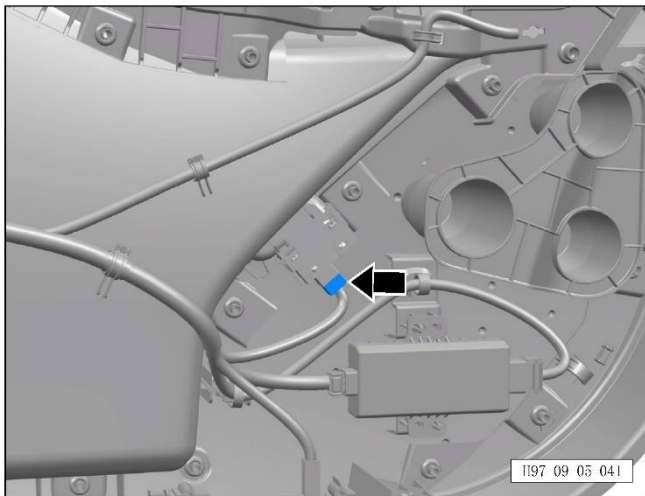

- b. Disengage 4 fixing clips of the POT opening/closing switch to remove the POT opening/closing switch ①.

Refitting procedure

The refitting procedure is performed in reverse order.

9.6.7.4 Removal and refitting of POT closing switch

Removal procedure

1. Turn off all electrical appliances and the start switch.
2. Disconnect the negative terminal of the battery (refer to [3.1.7.1 Maintenance and inspection of battery](#))
3. Remove the POT closing switch.
 - a. Disengage 2 fixing clips of the POT closing switch.
 - b. Disconnect the connector of the POT closing switch to remove the POT closing switch ①.

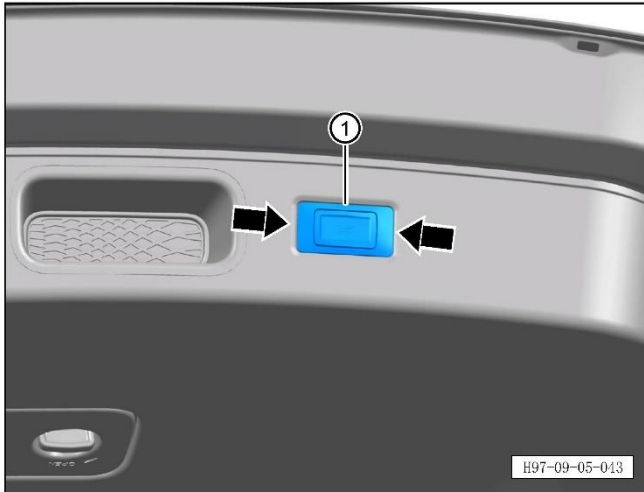

Refitting procedure

The refitting procedure is performed in reverse order.

9.6.7.5 Removal and refitting of trunk lid opening switch

Removal procedure

1. Turn off all electrical appliances and the start switch.
2. Disconnect the negative terminal of the battery (refer to [3.1.7.1 Maintenance and inspection of battery](#))
3. Remove the rear wiper arm and blade assembly (refer to [8.6.7.16 Removal and refitting of rear wiper arm and blade assembly](#))
4. Remove the tailgate lower trim panel assembly (refer to [8.4.4.4 Removal and refitting of tailgate lower trim panel assembly](#))
5. Remove the rear wiper motor and bracket assembly (refer to [8.6.7.17 Removal and refitting of rear wiper motor and bracket assembly](#))
6. Remove the POT opening switch.

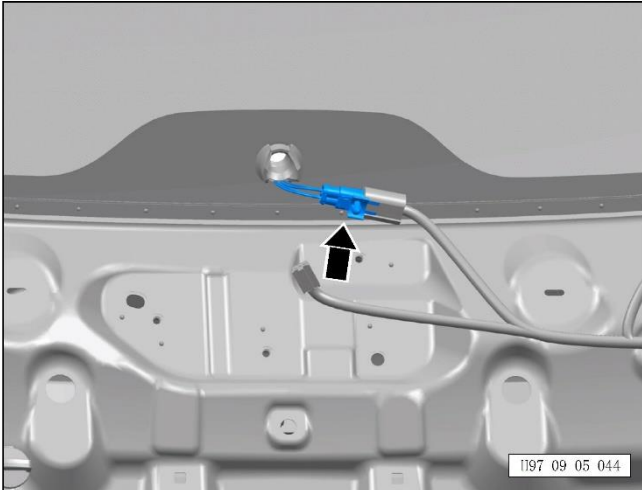

a. Disconnect the connector of the POT opening switch.

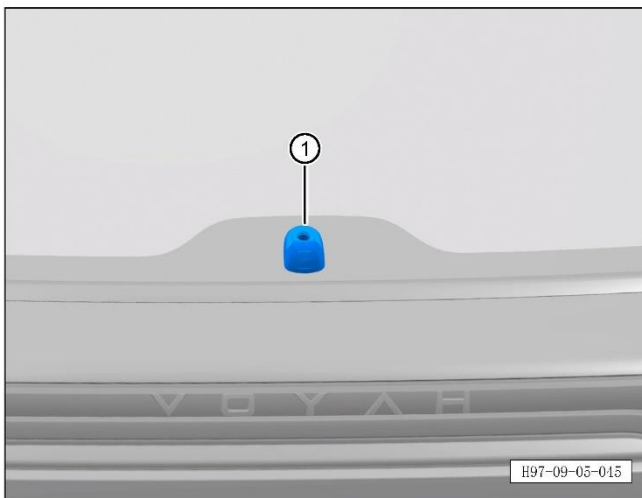

b. Remove the POT opening switch ①.

Refitting procedure

The refitting procedure is performed in reverse order.

9.6.7.6 Removal and refitting of POT controller

Removal procedure

1. Turn off all electrical appliances and the start switch.
2. Disconnect the negative terminal of the battery (refer to [3.1.7.1 Maintenance and inspection of battery](#))
3. Remove the tailgate lower trim panel assembly (refer to [8.6.7.17 Removal and refitting of rear wiper motor and bracket assembly](#))
4. Remove the POT controller.

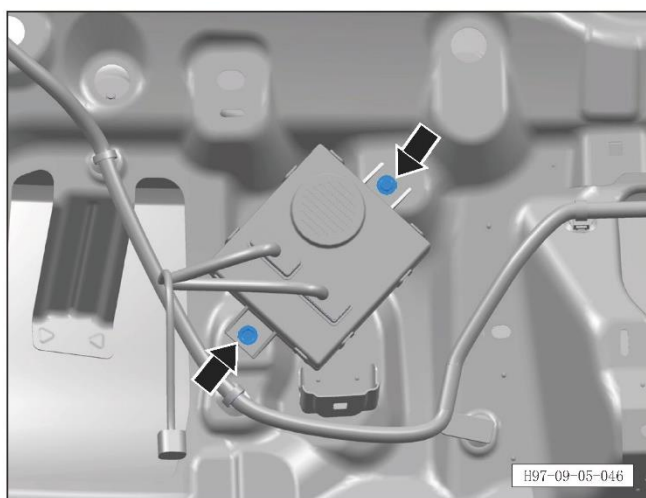

- a. Unscrew 2 fixing bolts of the POT controller.
Tightening torque of bolt: $8\pm 1\text{Nm}$.

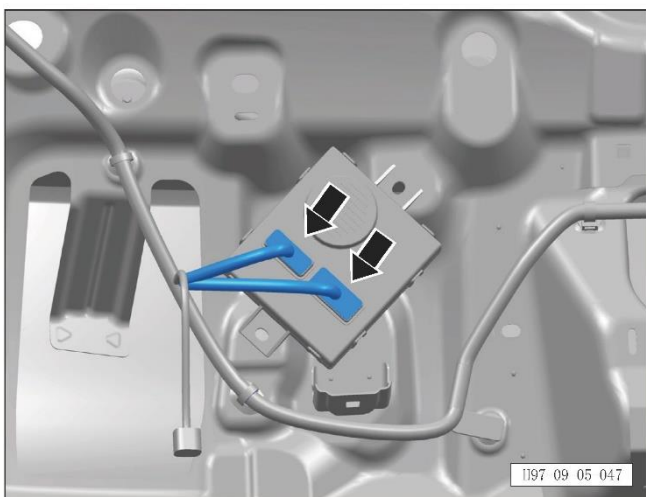

- b. Disconnect 2 connectors of the POT controller.

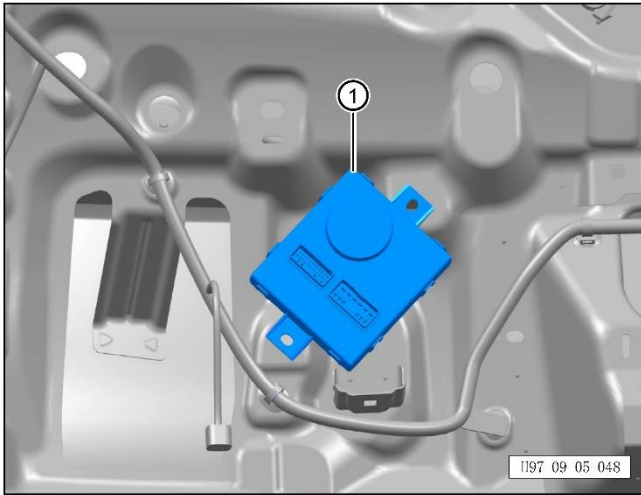

c. Remove the POT controller ①.

Refitting procedure

The refitting procedure is performed in reverse order.

9.6.8 EPB control device

9.6.8.1 Description and operation

Electronic parking brake (EPB)

The driver can apply or release the EPB by operating the EPB button. HSA function can be enabled on the slope. After the accelerator pedal is depressed in the parking situation, the EPB will be automatically released to provide the driver with convenient driving assistance.

Autohold

Autohold will automatically keep the vehicle stationary according to the driver's braking demands; when the system detects the driver's intention to start (such as depressing the accelerator pedal), the brake will be automatically released; it can ensure the convenience for the vehicle start during the automatic brake release based on the slope information; when the braking force is insufficient, the pressure will be automatically boosted to stop the vehicle.

-

9.6.8.2 Position diagram of parts



9.6.8.3 Removal and refitting of EPB switch

Removal procedure

1. Turn off all electrical appliances and the start switch.
2. Disconnect the negative terminal of the battery (refer to [3.1.7.1 Maintenance and inspection of battery](#))
3. Remove the upper panel assembly (refer to [8.3.4.2 Removal and refitting of upper panel assembly](#))
4. Remove the EPB switch.

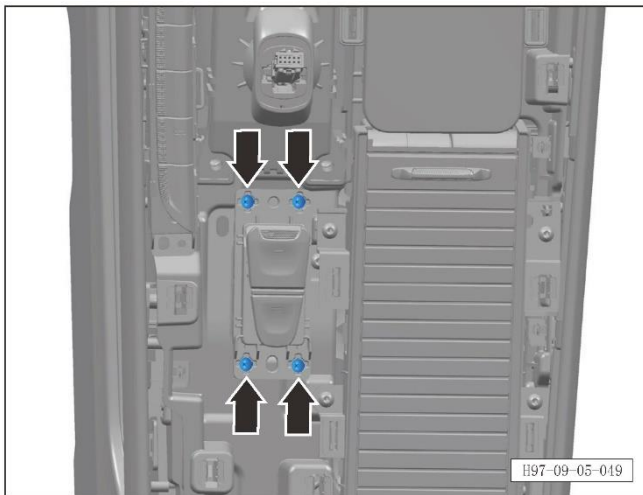

- a. Unscrew 4 fixing screws of the EPB switch.

Tightening torque of screw: $1.5 \pm 0.5 \text{ Nm}$



- b. Disconnect the connector of the EPB switch to remove the EPB switch ①.

Refitting procedure

The refitting procedure is performed in reverse order.

9.7 PEPS

9.7.1 Description and operation

Smart key and emergency mechanical key

By utilizing the wireless remote control function, the smart key can realize the automatic entry, passive entry, engine remote start, remote vehicle search, remote alarm and remote locking or unlocking of all doors and opening the trunk lid.

The mechanical key can lock or unlock the driver side door, but cannot start the vehicle.

The mechanical key is used in an emergency, and if the smart key does not work, the mechanical key can be used to open the driver side door.

Remote control function

The key contains an electronic circuit that triggers the anti-theft start locking system, and if the circuit is damaged, the key may not be able to start the vehicle.

- Avoid placing keys in direct sunlight, high temperature and humidity.
- Avoid dropping keys from high places or placing heavy objects on them.
- Avoid exposing the key to liquids, wipe it immediately with a soft cloth if it gets wet.

Do not disassemble keys unless replacing them, and if the circuit inside the keys is damaged, they may not be able to start the vehicle and the smart key may not work as well.

Low strength of smart key signal

When locking/unlocking the doors, opening the trunk lid, or starting the vehicle, the vehicle emits radio waves to locate the smart key.

Kick sensor

In the middle of the rear bumper and within 1.5 m from the rear bumper, lift your foot close to the rear bumper and kick your toes into the rear bumper at least 10 cm, then swing left and right to open and close the tailgate.

9.7.2 Position diagram of parts

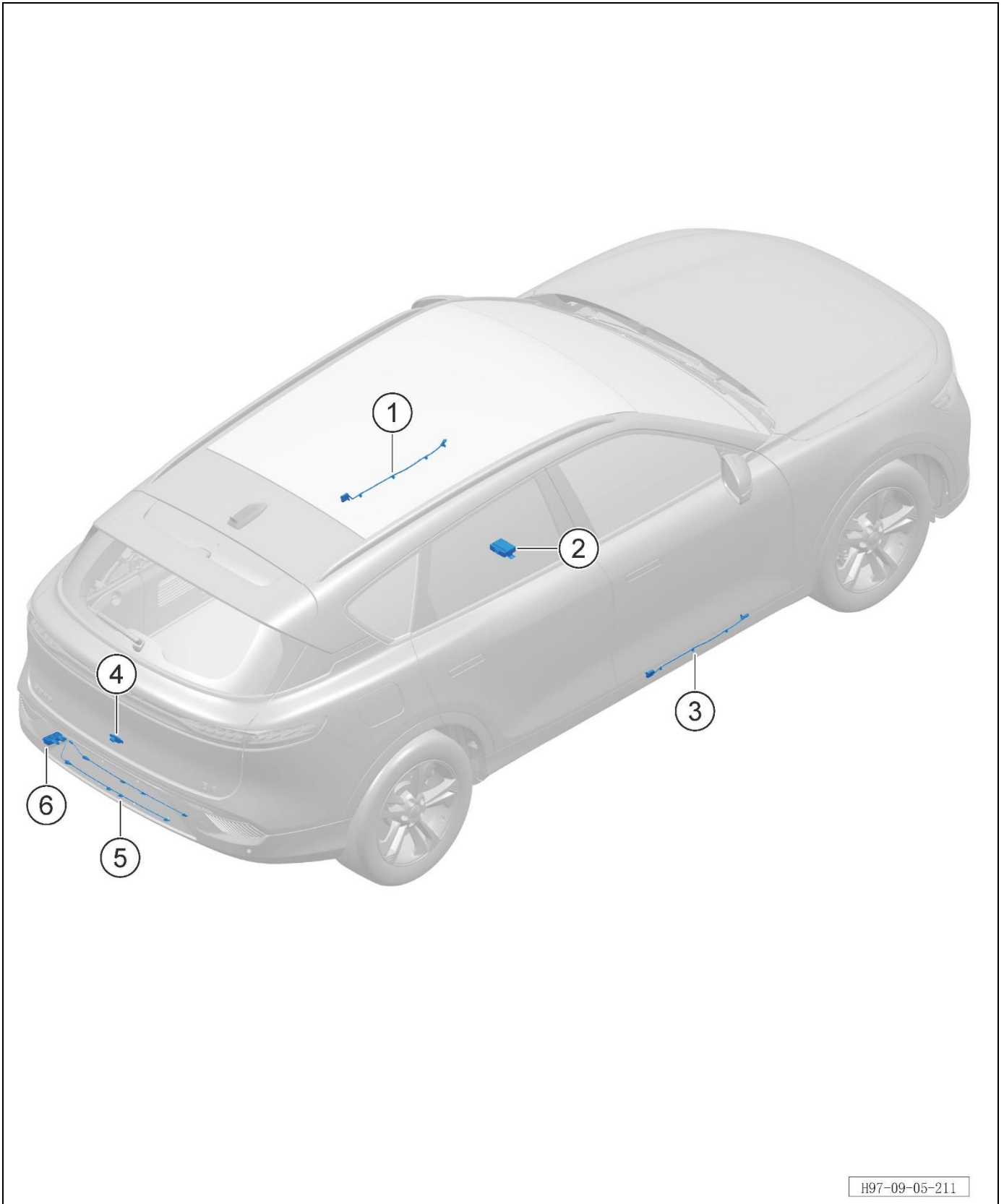

S/N	Part name	Loading quantity	Remarks
1	Left front door low power consumption bluetooth auxiliary module	1	
2	Low power consumption bluetooth main module	1	
3	Left front door low power consumption bluetooth auxiliary module	1	
4	Rear bumper low power consumption bluetooth auxiliary module	1	
5	Kick sensor strip	1	
6	Kick controller	1	

9.7.3 PEPS antenna

9.7.3.1 Removal and refitting of front door PEPS antenna

Removal procedure

Note:

- The following is the removal and refitting of the left front door PEPS antenna, which can be referred to for the operations on the right side.

1. Turn off all electrical appliances and the start switch.
2. Disconnect the negative terminal of the battery (refer to [3.1.7.1 Maintenance and inspection of battery](#))
3. Remove the left front door guard strip assembly (refer to [8.6.6.2 Removal and refitting of front door guard strip assembly](#))
4. Remove the left front door PEPS antenna.

a. Unscrew 2 fixing screws of the left front door PEPS antenna.

Tightening torque of screw: $2.5 \pm 0.5 \text{ Nm}$

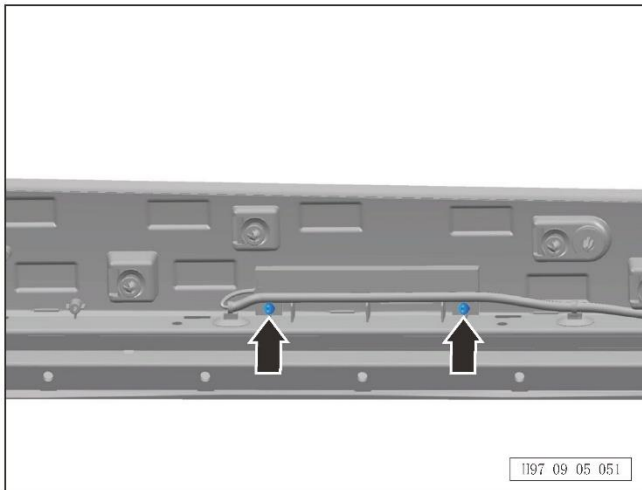

b. Disengage 5 fixing clips of the left front door PEPS antenna to remove the left front door PEPS antenna ①.

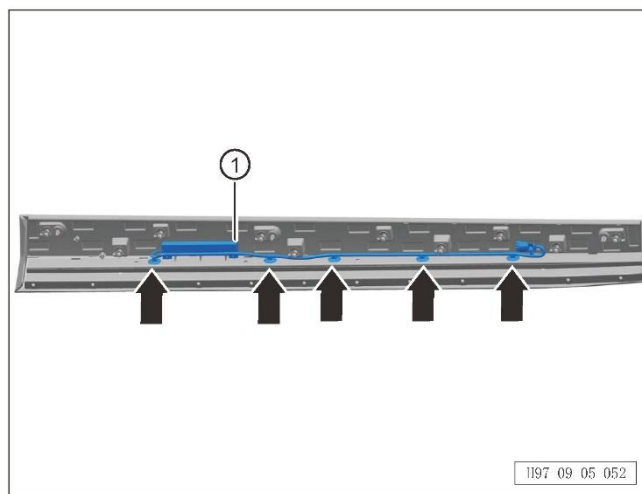

Refitting procedure

The refitting procedure is performed in reverse order.

9.7.4 Smart remote key

9.7.4.1 Removal and refitting of smart remote key battery

Removal procedure

1. Remove and refit the smart remote key battery

a. Press the A button and take out the emergency mechanical key as indicated by the arrow B.



b. Disengage the fixing clip of the smart remote key housing ①.

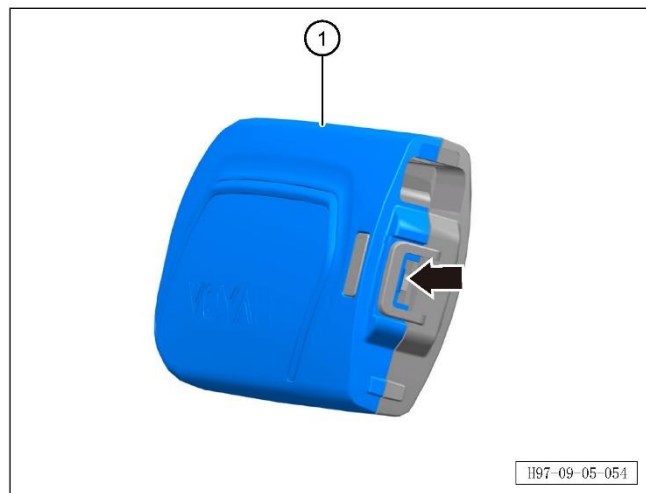

c. Take out the smart remote key battery ①.

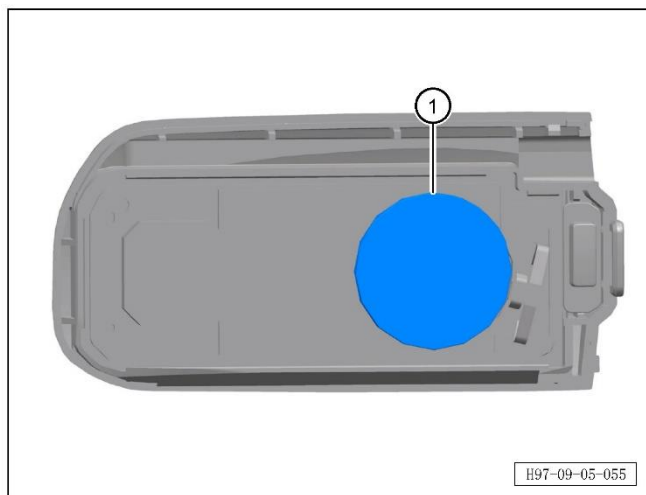

Refitting procedure

The refitting procedure is performed in reverse order.

9.7.5 Digital key Bluetooth module

9.7.5.1 Removal and refitting of low power consumption Bluetooth main module

Removal procedure

1. Turn off all electrical appliances and the start switch.
2. Disconnect the negative terminal of the battery (refer to [3.1.7.1 Maintenance and inspection of battery](#))
3. Remove the console assembly (refer to [8.3.4.22 Removal and refitting of console assembly](#))
4. Remove the low consumption Bluetooth main module.

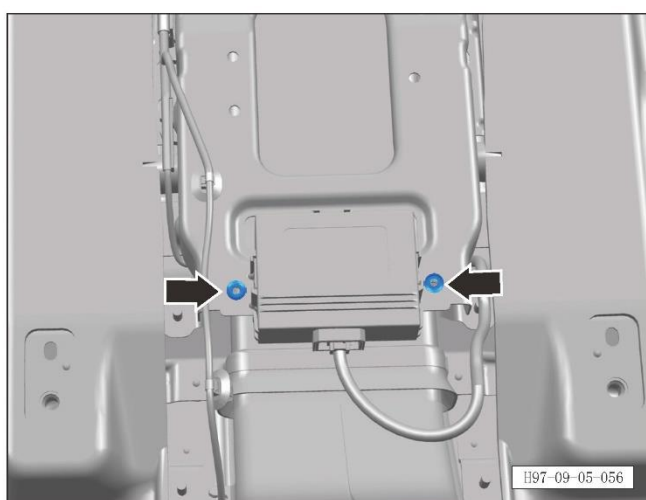

- a. Unscrew 2 fixing nuts of the low power consumption Bluetooth main module.

Tightening torque of nut: $8\pm 1\text{Nm}$.

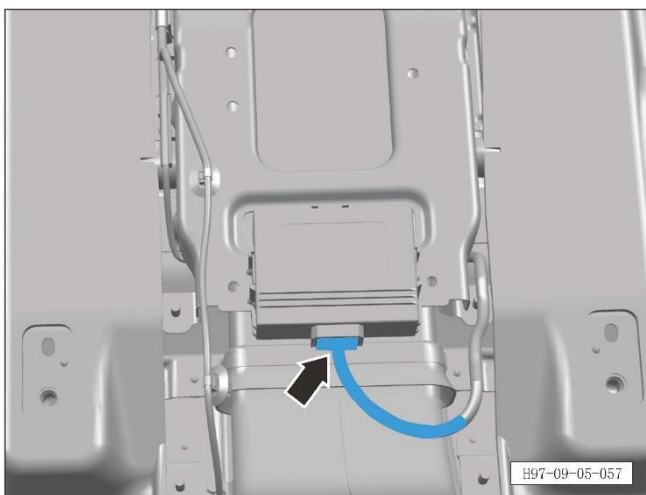

- b. Disconnect the connector of the low power consumption Bluetooth main module.

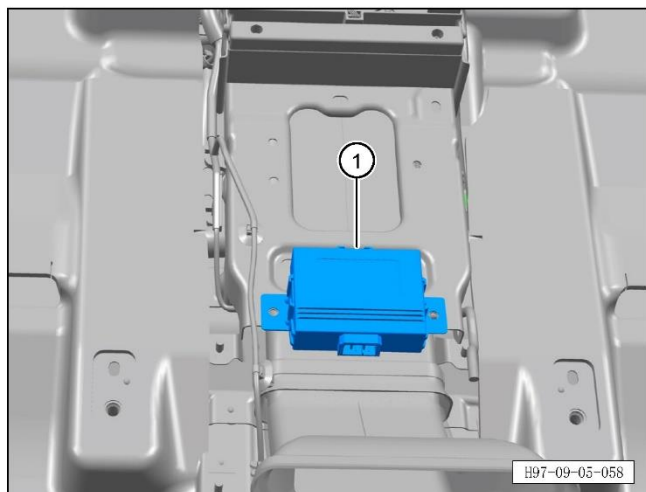

c. Remove the low power consumption Bluetooth main module ①.

Refitting procedure

The refitting procedure is performed in reverse order.

9.7.5.2 Removal and refitting of front door low power consumption Bluetooth auxiliary module

Removal procedure

Note:

- The following is the removal and refitting of the left front door low power consumption Bluetooth auxiliary module, which can be referred to for the operations on the right front side.

1. Turn off all electrical appliances and the start switch.
2. Disconnect the negative terminal of the battery (refer to [3.1.7.1 Maintenance and inspection of battery](#))
3. Remove the left front door guard strip assembly (refer to [8.6.6.2 Removal and refitting of front door guard strip assembly](#))
4. Remove the left front door low power consumption Bluetooth auxiliary module.

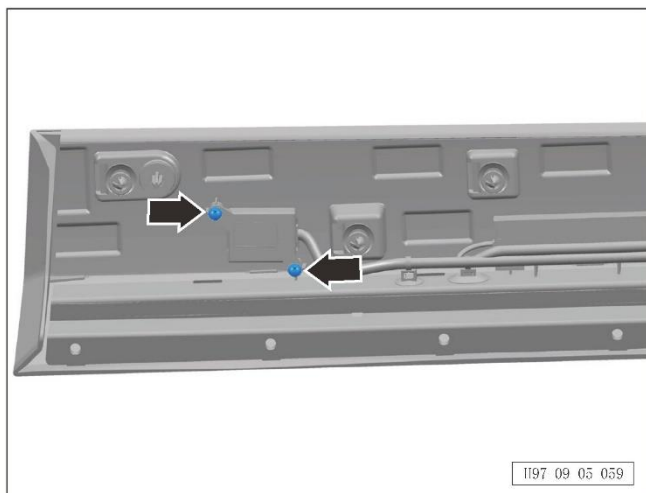

- a. Unscrew 2 fixing screws of the left front door low power consumption Bluetooth auxiliary module.
Tightening torque of screw: $2.5 \pm 0.5 \text{ Nm}$

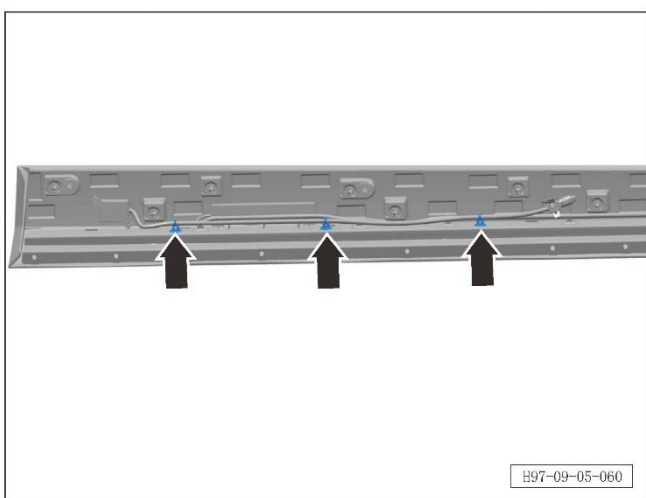

- b. Disengage 3 fixing clips of the left front door low power consumption Bluetooth auxiliary module.

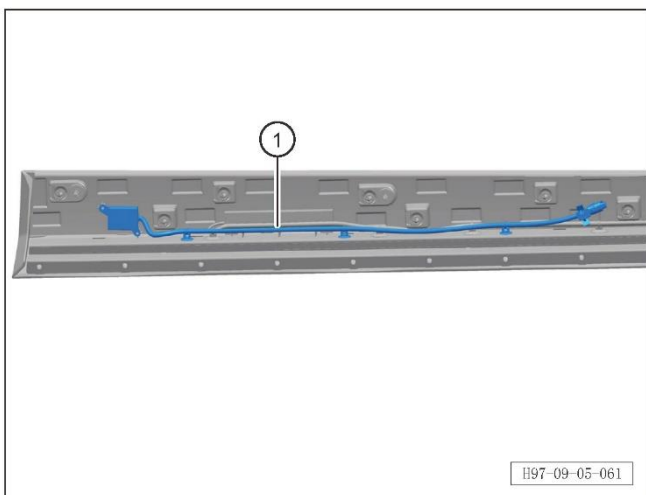

- c. Remove the left front door low power consumption Bluetooth auxiliary module ①.

Refitting procedure

The refitting procedure is performed in reverse order.

9.7.5.3 Removal and refitting of rear bumper low power consumption Bluetooth auxiliary module

Removal procedure

1. Turn off all electrical appliances and the start switch.
2. Disconnect the negative terminal of the battery (refer to [3.1.7.1 Maintenance and inspection of battery](#))
3. Remove the rear bumper assembly (refer to [8.6.3.10 Removal and refitting of rear bumper assembly](#))
4. Remove the rear bumper upper mounting base (refer to [8.6.3.13 Removal and refitting of rear bumper upper mounting base](#))
5. Remove the rear bumper low power consumption Bluetooth auxiliary module.

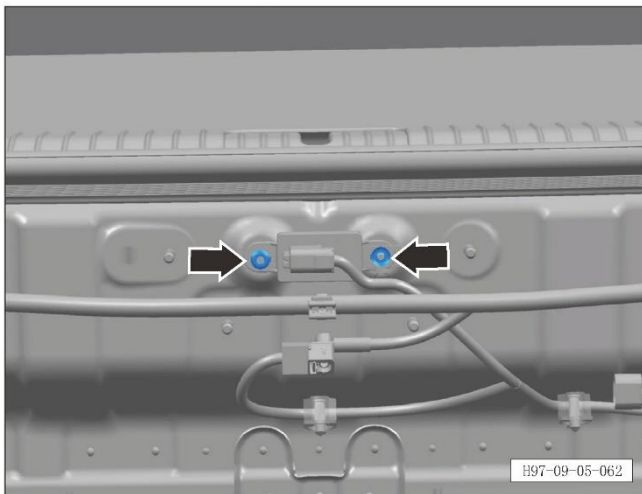

- a. Unscrew 2 fixing nuts of the rear bumper low power consumption Bluetooth auxiliary module.

Tightening torque of nut: $8\pm 1\text{Nm}$.

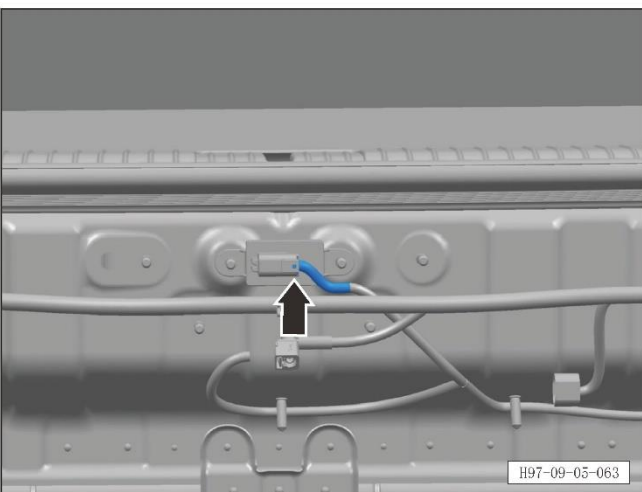

- b. Disconnect the connector of the rear bumper low power consumption Bluetooth auxiliary module.

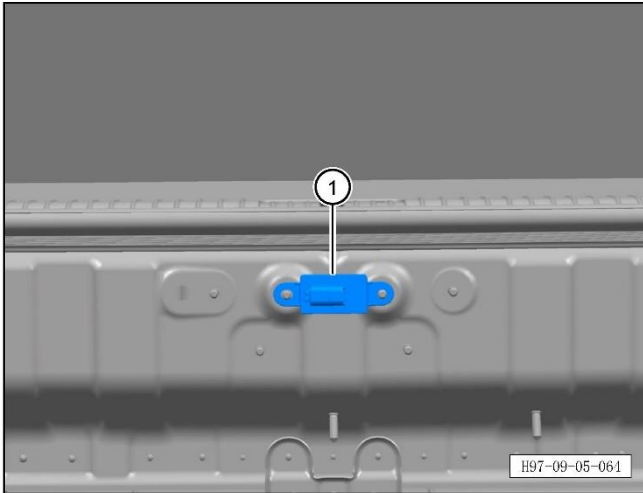

c. Remove the rear bumper low power consumption Bluetooth auxiliary module ①.

Refitting procedure

The refitting procedure is performed in reverse order.

9.7.6 Kick opening/closing sensing device

9.7.6.1 Removal and refitting of kick controller

Removal procedure

1. Turn off all electrical appliances and the start switch.
2. Disconnect the negative terminal of the battery (refer to [3.1.7.1 Maintenance and inspection of battery](#))
3. Remove the rear bumper assembly (refer to [8.6.3.10 Removal and refitting of rear bumper assembly](#))
4. Remove the kick controller.

a. Unscrew 3 fixing screws of the kick controller.

Tightening torque of screw: $2.5 \pm 0.5 \text{ Nm}$

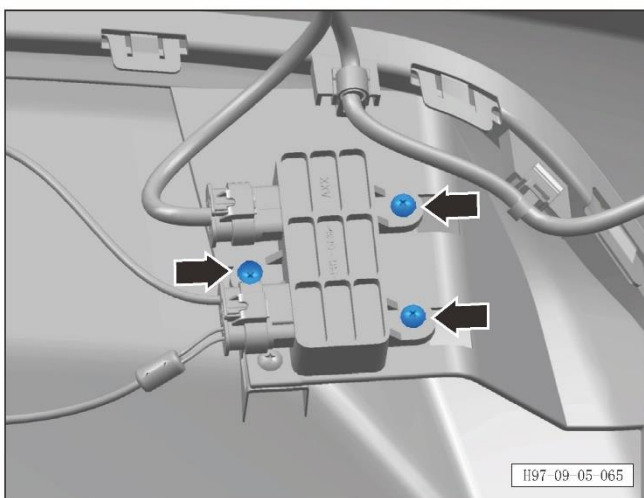

b. Disconnect the connector A of the rear bumper harness and the connector B of the kick controller.

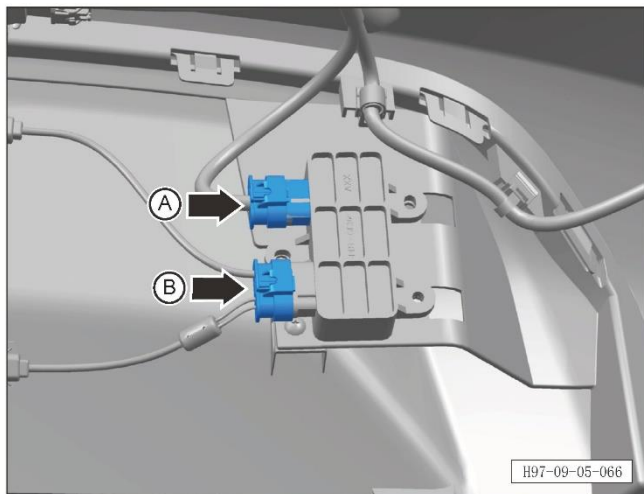

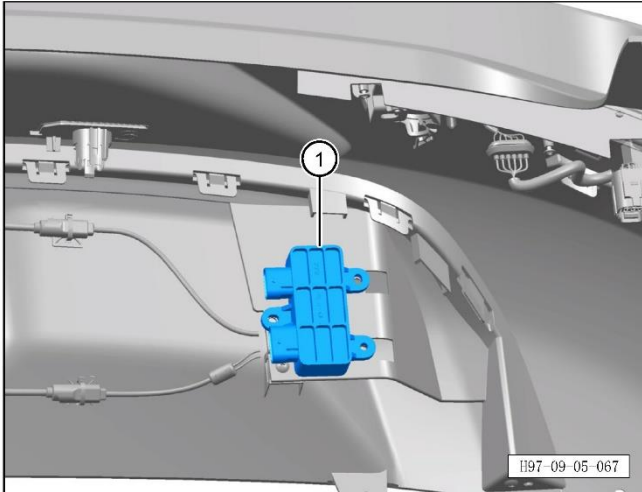

c. Take out the kick controller ①.

Refitting procedure

The refitting procedure is performed in reverse order.

9.7.6.2 Removal and refitting of kick sensor strip

Removal procedure

1. Turn off all electrical appliances and the start switch.
2. Disconnect the negative terminal of the battery (refer to [3.1.7.1 Maintenance and inspection of battery](#))
3. Remove the rear bumper assembly (refer to [8.6.3.10 Removal and refitting of rear bumper assembly](#))
4. Remove the kick sensor strip.

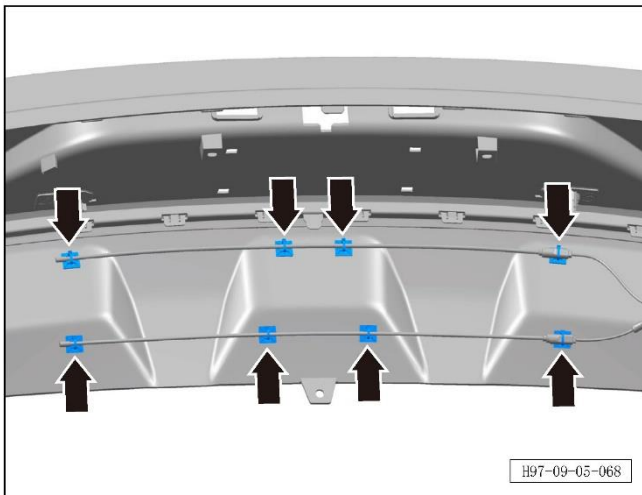

- a. Disengage 8 fixing clips of the kick sensor strip.

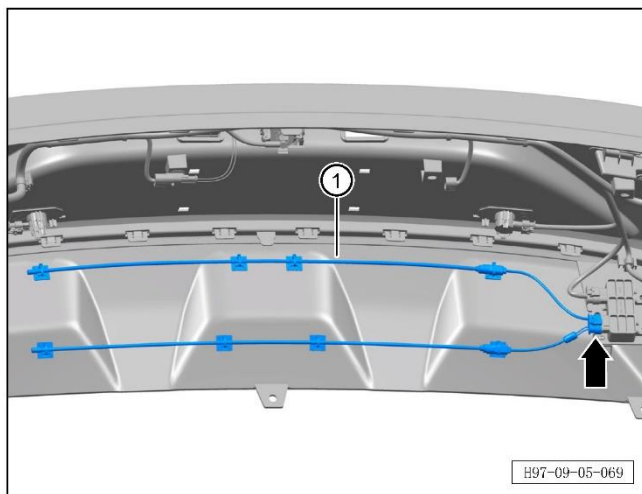

- b. Disconnect the connector of the kick sensor strip to remove the kick sensor strip ①.

Refitting procedure

The refitting procedure is performed in reverse order.

9.8 Driving monitoring and driving signal indication system

9.8.1 Description and operation

TPMS

The TPMS monitors the tire pressure and temperature information, and displays the current tire pressure and temperature information on the instrument cluster. When abnormal conditions of low pressure, high pressure, rapid air leakage and high temperature are found in tires, the IC will display the alarm information.

The alarm contents include: too low pressure alarm, too high pressure alarm, rapid air leakage alarm, and overly high tire temperature alarm.

DVR

It can be used to record the video of the vehicle in the process of driving, and can also provide evidence for traffic accidents.

When the DVR is turned on, REC will be displayed at the top of the CSD. The DVR can support continuous loop recording for up to 8 hours.

After 8 hours, the original video file will be overwritten.

The driving record function includes loop video recording and emergency video recording.

DMS

The DMS collects real-time images of the driver's facial expressions and hand movements through the in-vehicle infrared camera, and then transmits them to the in-vehicle camera controller for image recognition and analysis to complete the grasp of the driver's status and react accordingly.

OMS

After leaving and locking the vehicle, if there are still people in the vehicle, the system will send a reminder to the owner APP and upload the rear photos when the system detects people in the rear seats.

Night vision system

The NVS can clearly image when you drive at night, displaying detailed information of the road, such as pedestrians, vehicles, lane marking lines, traffic signals, objects scattered on the road, etc. Even objects that are not hot can be clearly detected.

9.8.2 Position diagram of parts

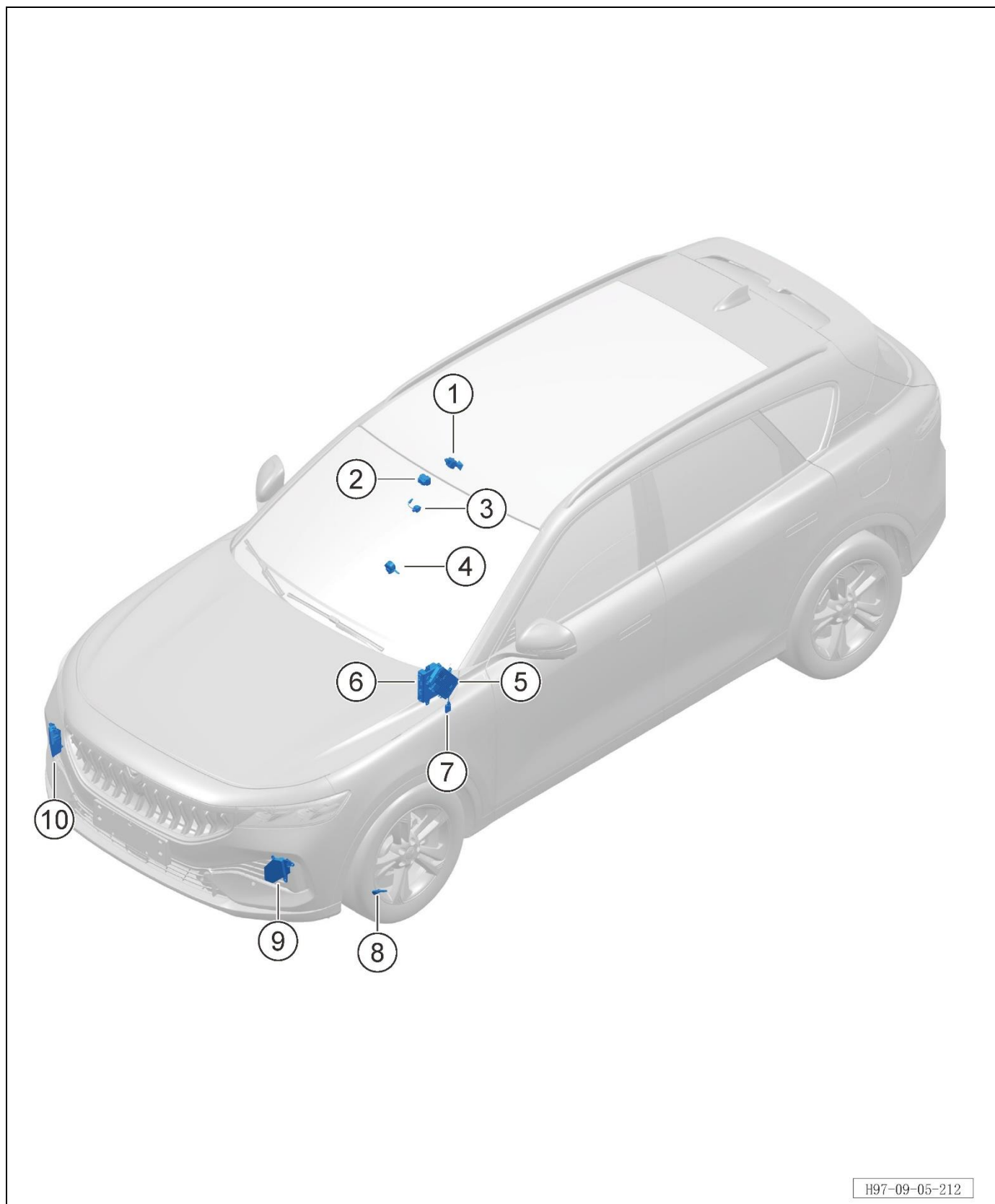

S/N	Part name	Loading quantity	Remarks
1	OMS camera	1	
2	NVS camera	1	
3	DVR camera	1	
4	DMS camera	1	
5	In-vehicle camera controller	1	
6	Night vision control unit	1	
7	Memory card module	1	
8	Tire pressure sensor	4	
9	NVS left fill lamp	1	
10	NVS right fill lamp	1	

9.8.3 TPMS

9.8.3.1 Removal and refitting of tire pressure sensor

Removal procedure

Note:

- The following is the removal and refitting of the left front tire pressure sensor, which can be referred to for operations on other wheels.

1. Turn off all electrical appliances and the start switch.
2. Remove the left front wheel assembly (refer to [6.5.9.2 Removal and refitting of wheels](#))
3. Remove the left front tire (refer to [6.5.10.2 Removal and refitting of tires](#))
4. Remove the left front tire pressure sensor.

a. Remove the left front tire pressure sensor ① from the rim as indicated by the arrow.

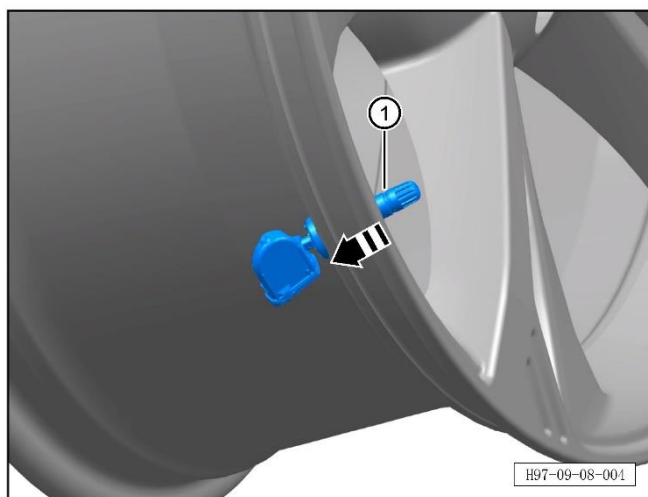

Refitting procedure

The refitting procedure is performed in reverse order.

9.8.4 DVR

9.8.4.1 Removal and refitting of DVR camera

Removal procedure

1. Turn off all electrical appliances and the start switch.
2. Disconnect the negative terminal of the battery (refer to [3.1.7.1 Maintenance and inspection of battery](#))
3. Remove the interior rearview mirror front trim cover (refer to [8.6.8.7 Removal and refitting of interior rearview mirror front trim cover](#))
4. Remove the DVR camera.

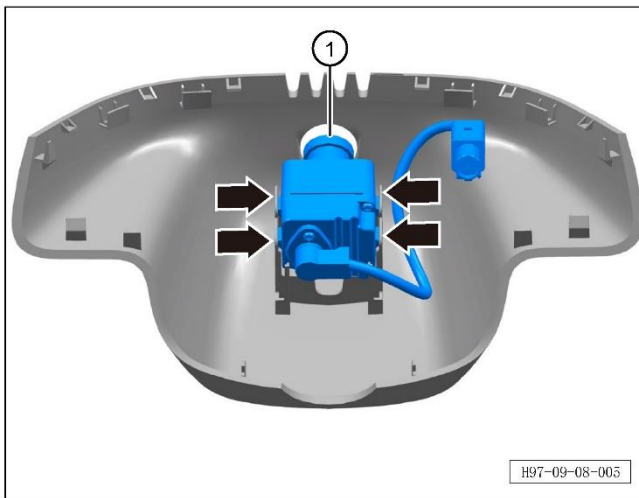

- a. Disengage 4 fixing clips of the DVR camera to remove the DVR camera ①.

Refitting procedure

The refitting procedure is performed in reverse order.

9.8.4.2 Removal and refitting of memory card module assembly

Removal procedure

1. Turn off all electrical appliances and the start switch.
2. Disconnect the negative terminal of the battery (refer to [3.1.7.1 Maintenance and inspection of battery](#))
3. Remove the IP left lower bottom plate assembly (refer to [8.2.4.31 Removal and refitting of IP left lower bottom plate assembly](#))
4. Remove the memory card module assembly.

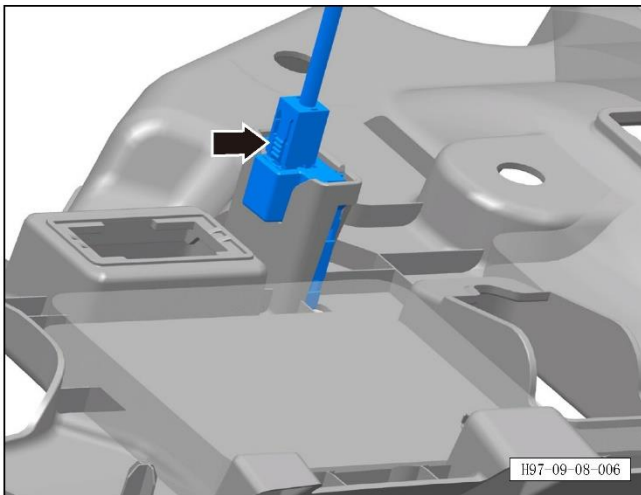

a. Disconnect the connector of the memory card module assembly.

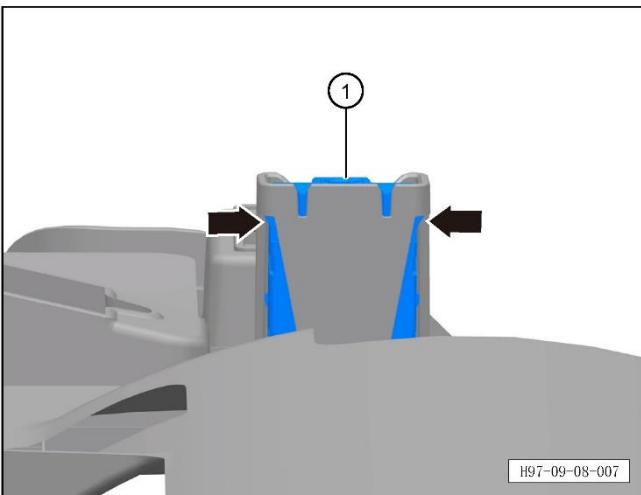

b. Disengage 2 fixing clips of the memory card module assembly to remove the memory card module assembly ①.

Refitting procedure

The refitting procedure is performed in reverse order.

9.8.5 DMS camera

9.8.5.1 Removal and refitting of in-vehicle camera controller

Removal procedure

1. Turn off all electrical appliances and the start switch.
2. Disconnect the negative terminal of the battery (refer to [3.1.7.1 Maintenance and inspection of battery](#))
3. Remove the left lower guard assembly (refer to [8.2.4.20 Removal and refitting of left lower guard assembly](#))
4. Remove the IP left lower bottom plate assembly (refer to [8.2.4.31 Removal and refitting of IP left lower bottom plate assembly](#))
5. Remove the in-vehicle camera controller.

a. Unscrew 2 fixing bolts on the lower part of the in-vehicle camera controller.

Tightening torque of bolt: $8\pm 1\text{Nm}$.

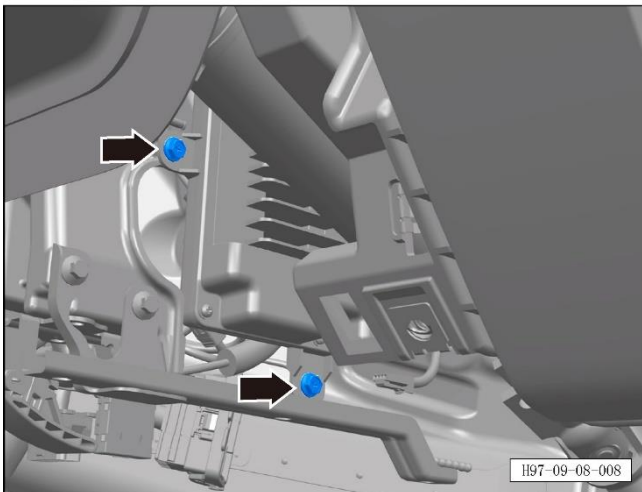

b. Unscrew 1 fixing bolt on the upper part of the in-vehicle camera controller.

Tightening torque of bolt: $8\pm 1\text{Nm}$.

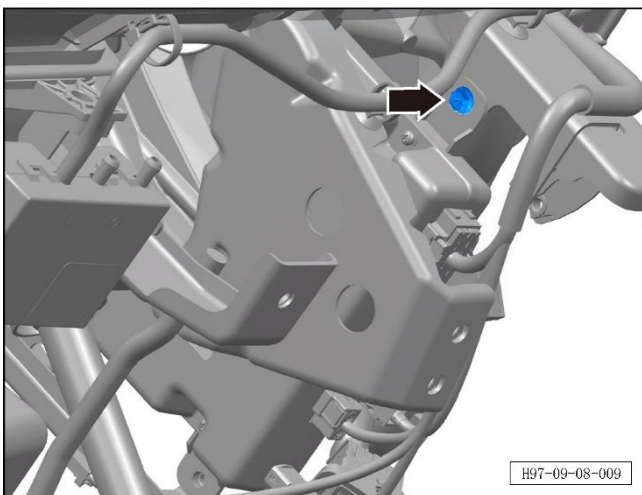

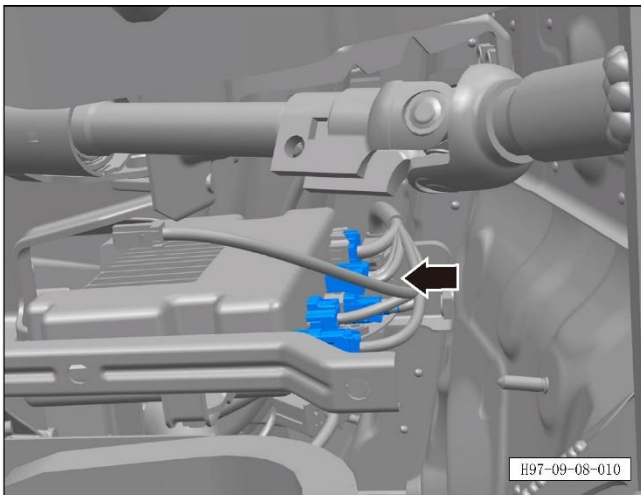

c. Disconnect 5 connectors of the in-vehicle camera controller.

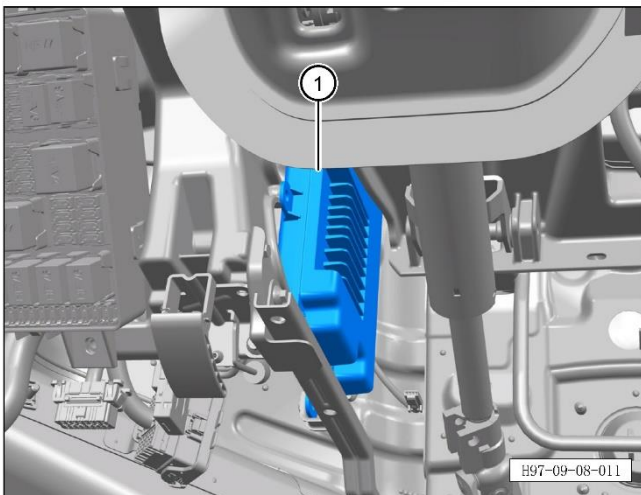

d. Remove the in-vehicle camera controller ①.

Refitting procedure

The refitting procedure is performed in reverse order.

9.8.5.2 Removal and refitting of DMS camera

Removal procedure

1. Turn off all electrical appliances and the start switch.
2. Disconnect the negative terminal of the battery (refer to [3.1.7.1 Maintenance and inspection of battery](#))
3. Remove the camera mount (refer to [8.2.4.7 Removal and refitting of camera mount](#))
4. Remove the DMS camera.

a. Unscrew 2 fixing screws of the DMS camera.

Tightening torque of screw: $1\pm 0.5\text{Nm}$

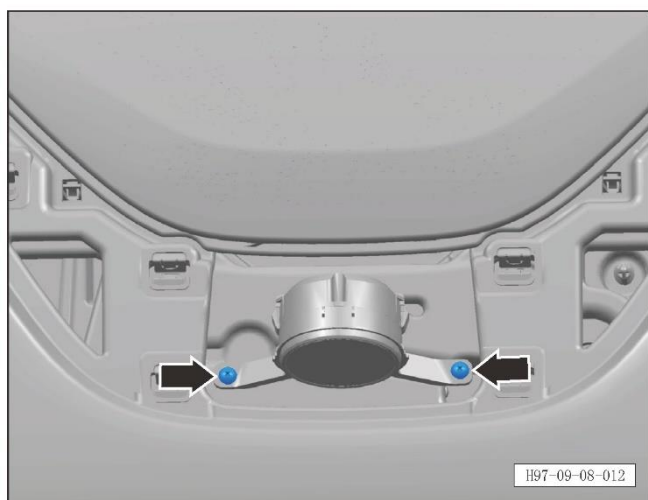

b. Disconnect the connector of the DMS camera to remove the DMS camera ①.

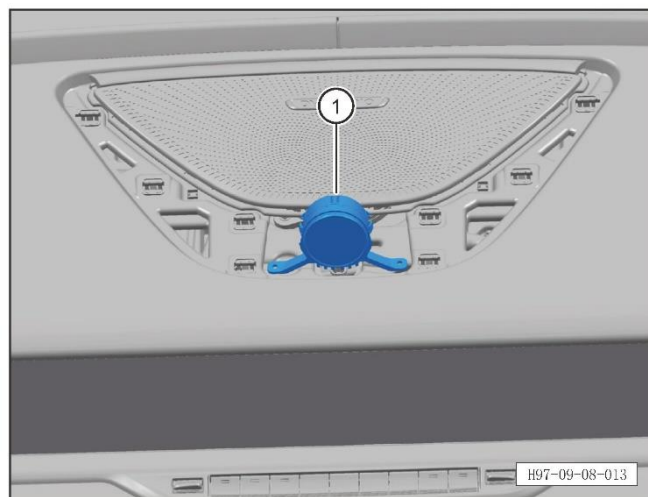

Refitting procedure

The refitting procedure is performed in reverse order.

9.8.5.3 Removal and refitting of OMS camera

Removal procedure

1. Turn off all electrical appliances and the start switch.
2. Disconnect the negative terminal of the battery (refer to [3.1.7.1 Maintenance and inspection of battery](#))
3. Remove the front ceiling lamp assembly (refer to [9.9.11.2 Front ceiling lamp assembly](#))
4. Remove the OMS camera.
 - a. Disengage 3 fixing clips of the OMS camera to remove the OMS camera ①.

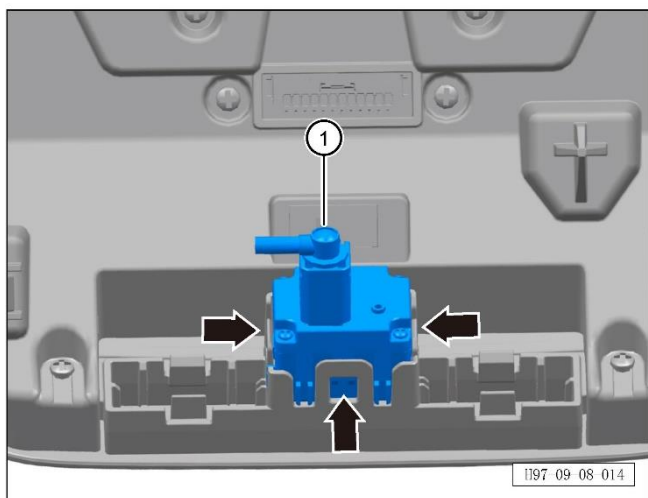

Refitting procedure

The refitting procedure is performed in reverse order.

9.8.6 Night vision

9.8.6.1 Removal and refitting of NVS camera

Removal procedure

1. Turn off all electrical appliances and the start switch.
2. Disconnect the negative terminal of the battery (refer to [3.1.7.1 Maintenance and inspection of battery](#))
3. Remove the interior rearview mirror front trim cover (refer to [8.6.8.7 Removal and refitting of interior rearview mirror front trim cover](#))
4. Remove the rear trim cover of interior rearview mirror (refer to [8.6.8.9 Removal and refitting of rear trim cover of interior rearview mirror](#))
5. Remove the NVS camera.

a. Disengage 2 fixing clips of the NVS camera.

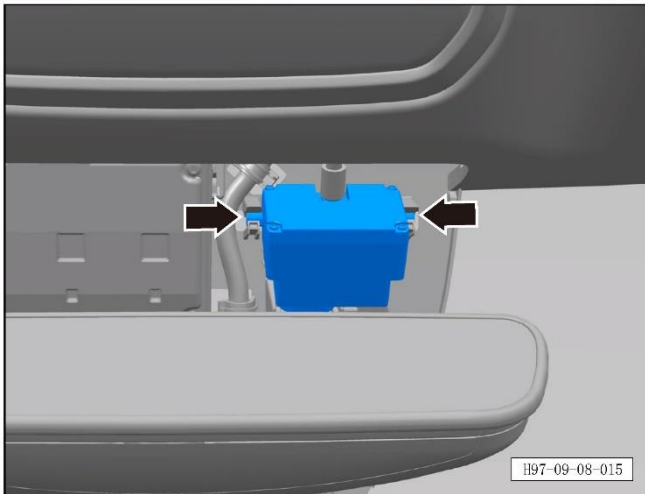

b. Disconnect the connector of the NVS camera to remove the NVS camera ①.

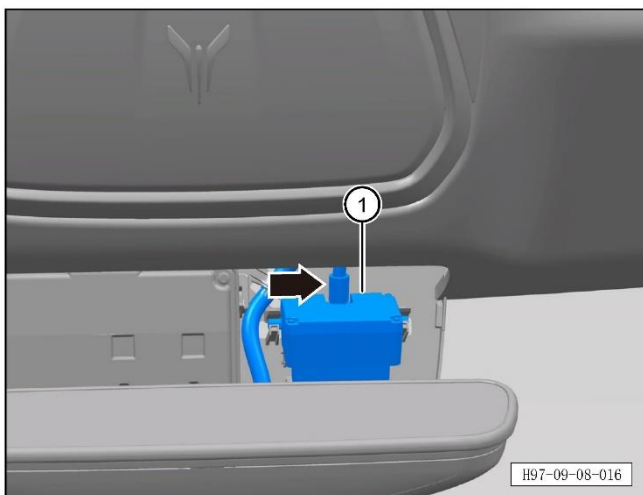

Refitting procedure

The refitting procedure is performed in reverse order.

9.8.6.2 Removal and refitting of NVS control unit

Removal procedure

1. Turn off all electrical appliances and the start switch.
2. Disconnect the negative terminal of the battery (refer to [3.1.7.1 Maintenance and inspection of battery](#))
3. Remove the left lower guard assembly (refer to [8.2.4.20 Removal and refitting of left lower guard assembly](#))
4. Remove the IP left lower bottom plate assembly (refer to [8.2.4.31 Removal and refitting of IP left lower bottom plate assembly](#))
5. Remove the NVS control unit.

- a. Unscrew 2 fixing bolts on the lower part of the NVS control unit.

Tightening torque of bolt: $8\pm 1\text{Nm}$.

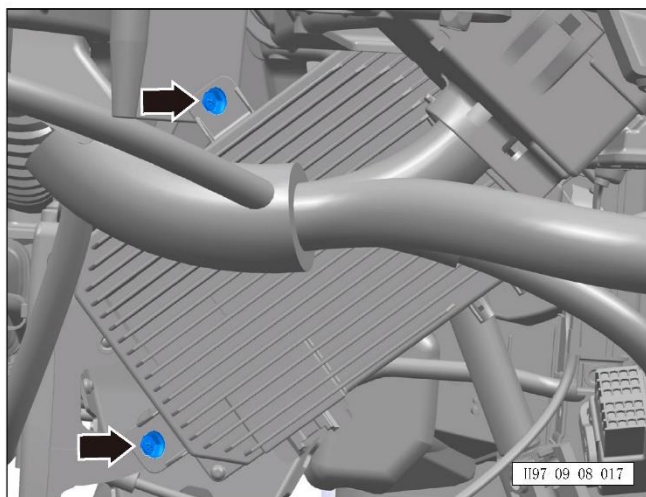

- b. Unscrew 1 fixing bolt on the upper part of the NVS control unit.

Tightening torque of bolt: $8\pm 1\text{Nm}$.

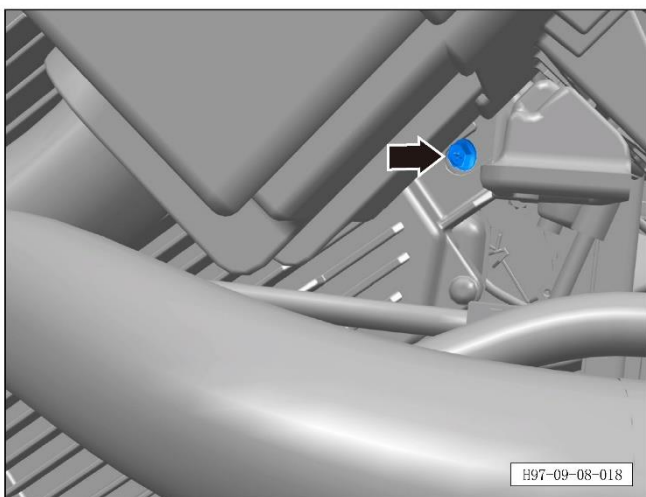

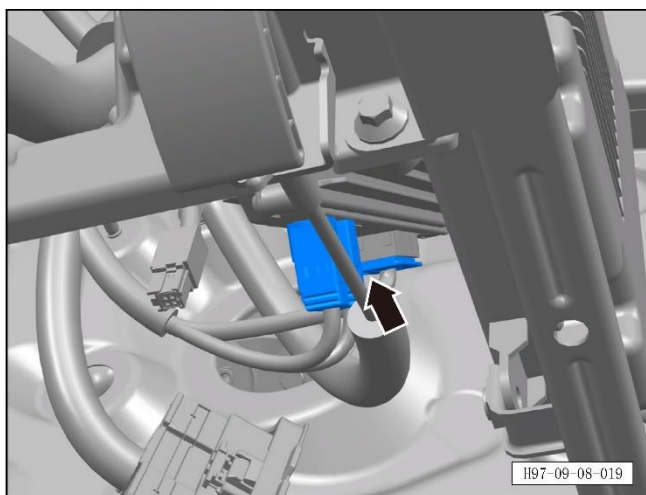

c. Disconnect 3 connectors of the NVS control unit.

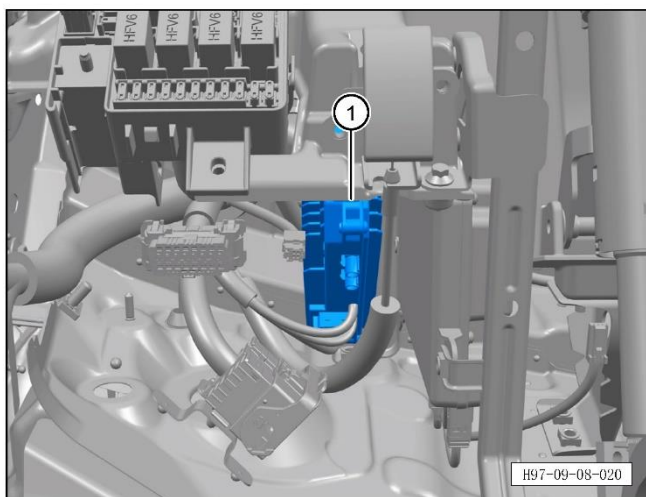

d. Remove the NVS control unit ①.

Refitting procedure

The refitting procedure is performed in reverse order.

9.8.6.3 Removal and refitting of NVS fill lamp

Removal procedure

Note:

- The following is the removal and refitting of the NVS left fill lamp, which can be referred to for the operations on the right side.

1. Turn off all electrical appliances and the start switch.
2. Disconnect the negative terminal of the battery (refer to [3.1.7.1 Maintenance and inspection of battery](#))
3. Remove the front bumper assembly (refer to [8.6.3.3 Removal and refitting of front bumper assembly](#))
4. Remove the NVS left fill lamp.

- a. Unscrew 3 fixing screws of the NVS left fill light. Tightening torque of screw: $2.5 \pm 1 \text{ Nm}$

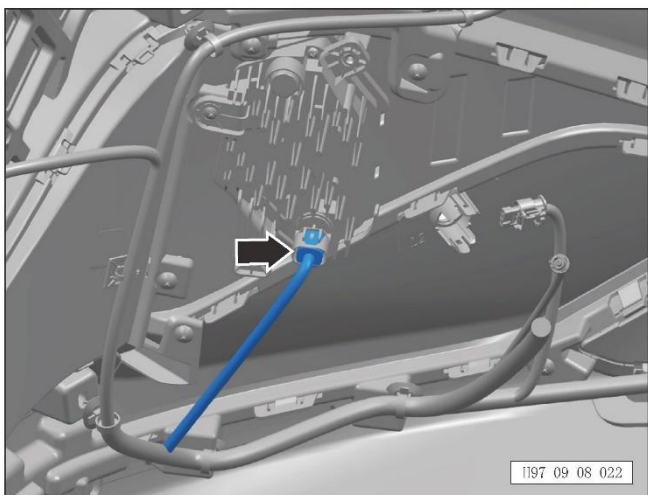
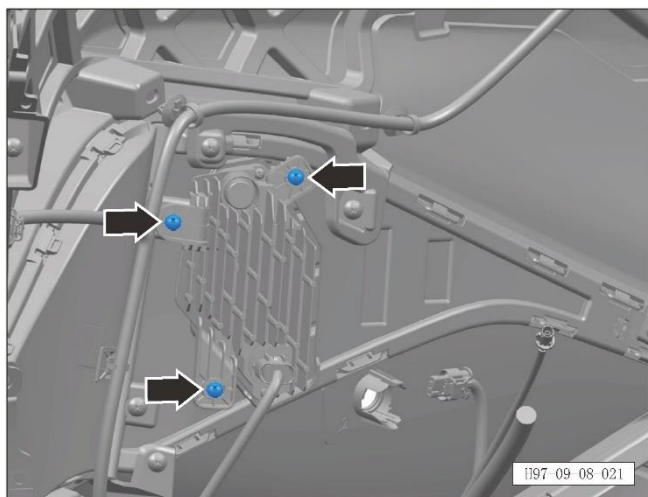

- b. Disconnect the connector of the NVS fill lamp.

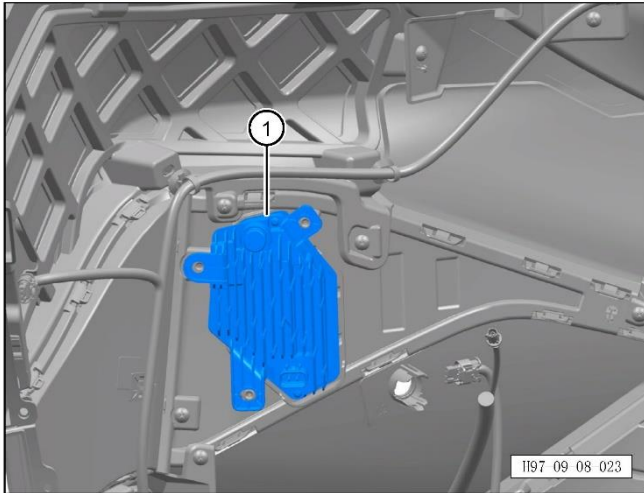

d. Remove the NVS left fill lamp ①.

Refitting procedure

The refitting procedure is performed in reverse order.

9.9 Lighting signal system

9.9.1 Description and operation

System description

The exterior lighting system of this model includes lamps with various functions that meet the requirements of relevant laws and regulations, and also has humanized functions such as automatic follow-me-home, vehicle search lighting, headlamp height adjustment, position lamps, daytime running lamps, etc. The driver can operate all lamps correspondingly through the relevant switches, smart remote keys (turn signal lamp).

The external lighting system mainly includes:

- Position lamp
- Low beam
- High beam
- Turn signal lamps, hazard warning lamps
- Rear fog lamp
- Daytime running lamp
- Brake lamp
- Reversing lamp
- 3rd brake lamp

The interior lighting system mainly includes:

- Ambient lamp
- Front door floor lamp
- Charging indicator
- Trunk lamp
- Front ceiling lamp
- Operating instructions for external lighting system of the rear ceiling lamp:

Position lamp

1. The engine start/stop button is placed in any position, and the position lamp switch is valid to turn on the position lamp.
2. Put the engine start/stop button in ON position and the lamp switch in AUTO position, then the rain/light sensor recognizes the environment through the lighting detection and lights up the position lamp.

Low beam & high beam

1. Put the engine start/stop button in ON position and the low beam switch signal is valid, then the low beam will be turned on.
2. Put the engine start/stop button in ON position and the low beam switch and the high beam switch are valid, then the high beam will be turned on.
3. Put the engine start/stop button in ON position and the lamp combination switch in AUTO position, then the rain/light sensor recognizes the environment through the lighting detection and lights up low beam.
4. Put the engine start/stop button in ON position and the lamp combination switch in the AUTO position, the rain/light sensor recognizes the environment through the lighting detection and lights up the high beam.

Turn signal lamp & hazard warning lamp

1. Put the engine start/stop button in ON position and the left/right turn signal lamps are valid, then the left/right turn signal lamp will flash.
2. Put the engine start/stop button in any position and the hazard alarm switch is valid, then the steering lamp on the left and right sides will flash synchronously.

Rear fog lamp

1. Put the engine start/stop button in ON position and the position lamp switch & low beam lamp switch & rear fog lamp switch are valid, then the rear fog lamp will be turned on.

Daytime Running Lamp

1. Put the engine start/stop button in ON position and turn off the position lamp switch to turn on the daytime running lamp.

Brake lamp & 3rd brake lamp

1. Place the engine start/stop button at any position and the brake switch is valid, then the brake lamp and the 3rd brake lamp will be turned on.

Reversing lamp

1. Put the engine start/stop button in ON position and the reverse switch is valid, then the reversing lamp will be turned on.

Headlamps go off after a delay

1. After the engine start/stop button is switched from the ON to OFF, the low beam can be temporarily illuminated so that the driver can leave the vehicle.
2. You can set Follow-me-home lamp to ON/OFF and then set the continuous illuminating time (15s, 30s, 60s) on the CSD through Vehicle → Lighting control → Headlamp settings → Follow-me-home lamp.

Operating instructions for internal lighting system:

Interior mood lighting

1. Put the engine start/stop button in the ON position and the ambient lamp switch is valid, then the ambient lamp will be turn on.
2. You can set ambient lamp to ON/OFF and adjust the color of the ambient lamp in CSD settings through Vehicle → Lighting control → Ambient lamp.

Front door floor lamp

1. Put the engine start/stop button in any position and open the front door to turn on the front door floor lamp.
2. You can set the courtesy lamp to ON/OFF in CSD settings through Vehicle → Lighting control → Headlamp settings → Courtesy lamp switch.

Charging indicator

1. Put the engine start/stop button in any position and charge the vehicle to turn on the charging indicator.

Trunk lamp

1. Put the engine start/stop button in any position and open the trunk lid, then the trunk lamp will be illuminated automatically.
2. Put the engine start/stop button in any position and close the trunk lid, then the trunk lamp will be automatically turned off.

Front ceiling lamp & rear ceiling lamp

1. Put the engine start/stop button in any position and press the button to turn on the reading lamp of the corresponding button.
2. Set the engine start/stop button to "OFF" and open any door, then the roof lamp will be automatically illuminated, and it will go out about 30 s after the door is closed.
3. Set the engine start/stop button to "OFF" and remotely unlock the vehicle door, then the roof lamp will be automatically illuminated, and it will go out after about 30 s.
4. Set the engine start/stop button from "ON" to "OFF", the roof lamp will be automatically illuminated, and it will go out after about 30 s.

9.9.2 Position diagram of parts

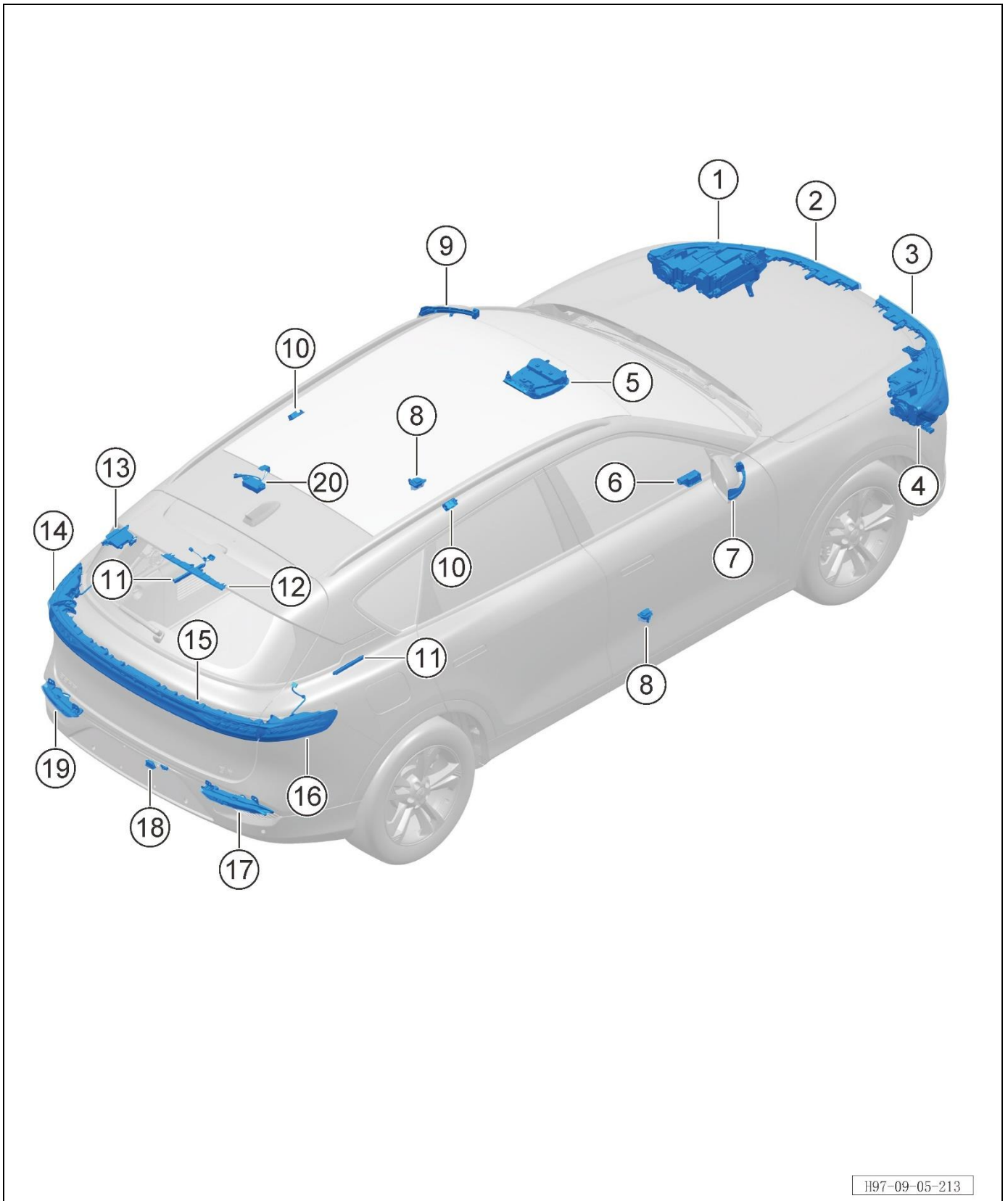

S/N	Part name	Loading quantity	Remarks
1	Left headlamp	1	
2	Left front position light	1	
3	Right front position lamp	1	
4	Right headlamp	1	
5	Front ceiling lamp	1	
6	Point light source	4	
7	Right turn signal lamp	1	
8	Front door floor lamp	2	
9	Left turn signal lamp	1	
10	Rear roof lamp	2	
11	Trunk lamp	2	
12	Third brake lamp	1	
13	Charging indicator	1	
14	LR combination lamp fixing side	1	
15	Rear combination lamp moving side	1	
16	RR combination lamp fixing side	1	
17	Right backfog light	1	
18	License plate lamp	2	
19	Left backfog light	1	
20	Stepless dimming glass controller	1	

9.9.3 Headlamp

9.9.3.1 Removal and refitting of headlamp

Removal procedure

Note:

- The following is the removal and refitting of the left headlamp, which can be referred to for the operations on the right front side.

1. Turn off all electrical appliances and the start switch.
2. Disconnect the negative terminal of the battery (refer to [3.1.7.1 Maintenance and inspection of battery](#))
3. Remove the engine compartment front middle trim panel assembly (refer to [8.6.6.11 Removal and refitting of engine compartment front middle trim panel assembly](#))
4. Remove the engine compartment front trim panel assembly (refer to [8.6.6.10 Removal and refitting of engine compartment front trim panel assembly](#))
5. Remove the front bumper assembly (refer to [8.6.3.3 Removal and refitting of front bumper assembly](#))
6. Remove the left headlamp.
 - a. Disconnect the connector of the left headlamp.

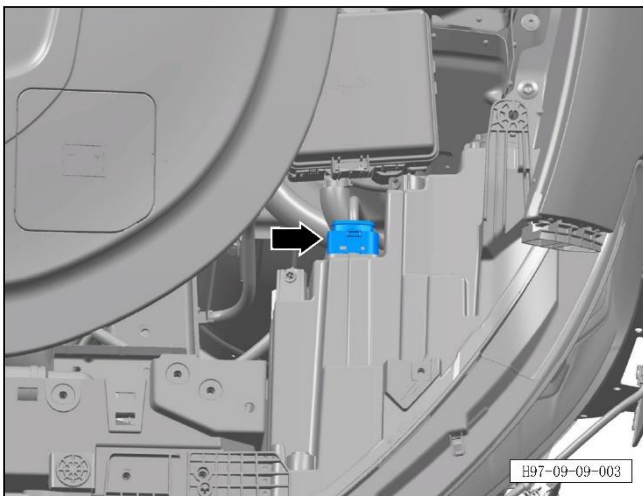

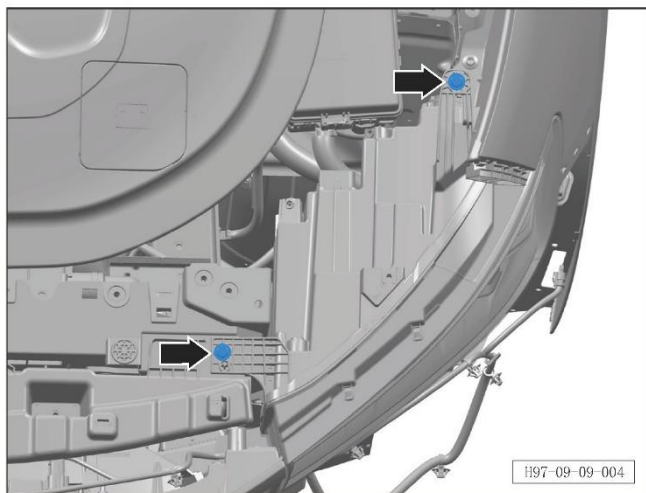

b. Unscrew 2 fixing bolts on the upper part of the left headlamp.

Tightening torque of bolt: $2.5\pm 1\text{Nm}$.

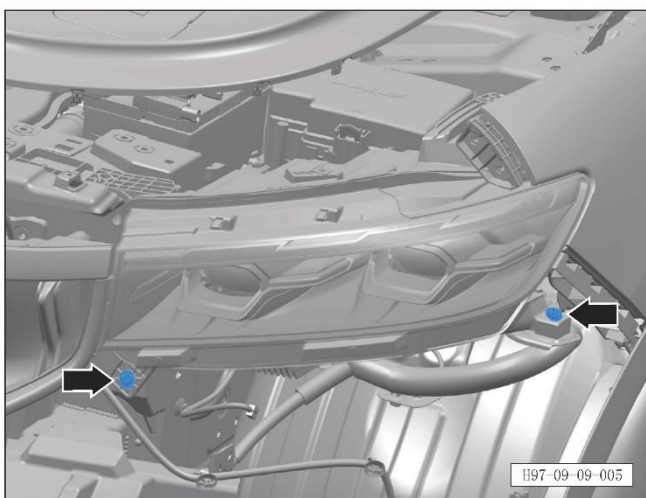

c. Unscrew 2 fixing bolts on the lower part of the left headlamp.

Tightening torque of bolt: $2.5\pm 1\text{Nm}$.

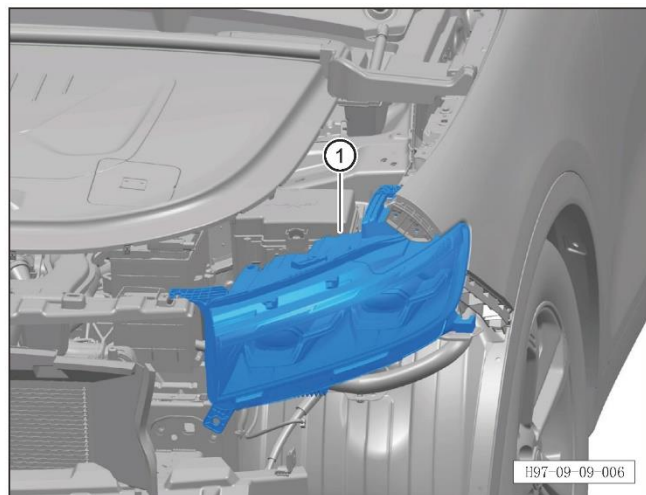

d. Remove the left headlamp ①.

Refitting procedure

The refitting procedure is performed in reverse order.

9.9.3.2 Removal and refitting of front position lamp

Removal procedure

Note:

- The following is the removal and refitting of the left front position lamp, which can be referred to for the operations on the right front side.

1. Turn off all electrical appliances and the start switch.
2. Disconnect the negative terminal of the battery (refer to [3.1.7.1 Maintenance and inspection of battery](#))
3. Remove the front bumper assembly (refer to [8.6.3.3 Removal and refitting of front bumper assembly](#))
4. Remove the left front position lamp.
 - a. Disconnect the connector of the left front position lamp.

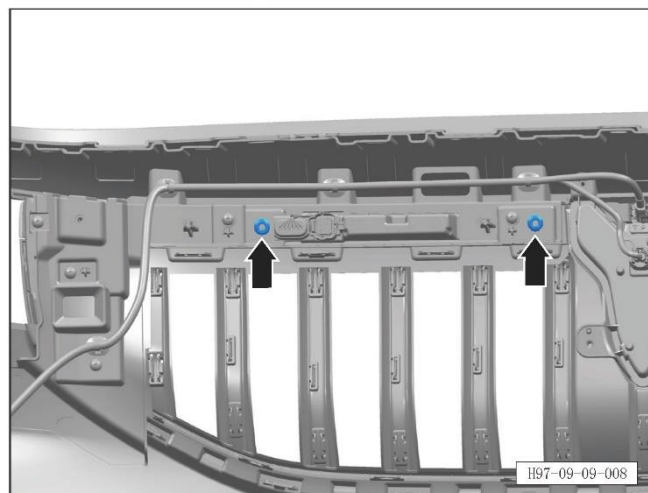
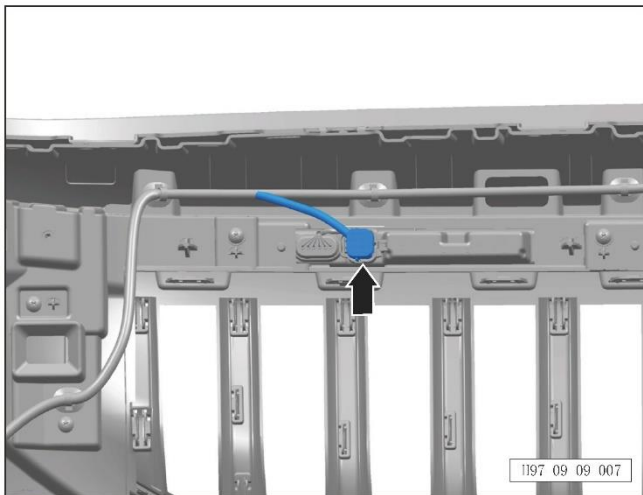

- b. Unscrew 2 fixing nuts of the left front position lamp. Tightening torque of bolt: $2.5\pm 1\text{Nm}$.

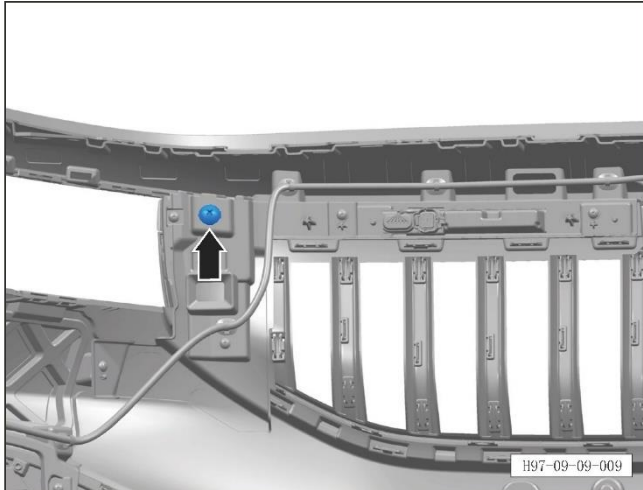

c. Unscrew 1 fixing screw of the left front position lamp.

Tightening torque of screw: $2.5\pm 1\text{Nm}$

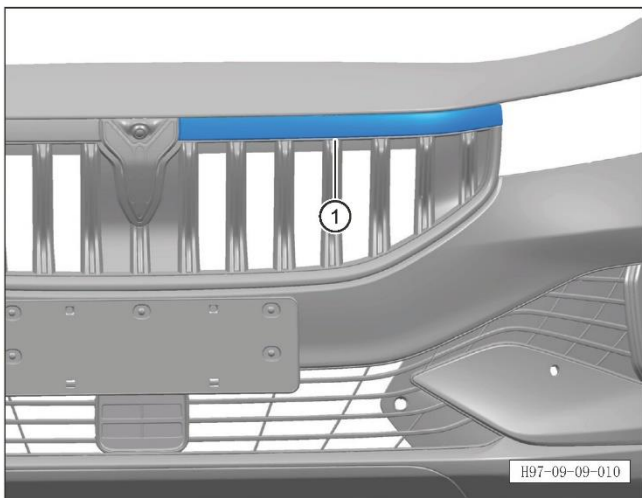

d. Remove the left front position lamp ①.

Refitting procedure

The refitting procedure is performed in reverse order.

9.9.4 Rear combination lamp

9.9.4.1 Removal and refitting of rear combination lamp fixed side

Removal procedure

Note:

- The following is the removal and refitting of the left rear combination lamp fixed side, which can be referred to for the operations on the right rear side.

1. Turn off all electrical appliances and the start switch.

2. Disconnect the negative terminal of the battery (refer to [3.1.7.1 Maintenance and inspection of battery](#))

3. Remove the left rear combination lamp fixed side plate (refer to [9.9.4.2 Removal and refitting of rear combination lamp fixed side plate](#))

4. Remove the left rear side wall inner trim panel assembly (refer to [8.5.5.10 Removal and refitting of rear side wall inner trim panel assembly](#))

5. Remove the left rear combination lamp fixed side.

a. Unscrew 2 fixing bolts of the left rear combination lamp fixed side.

Tightening torque of bolt: $8\pm 1\text{Nm}$.

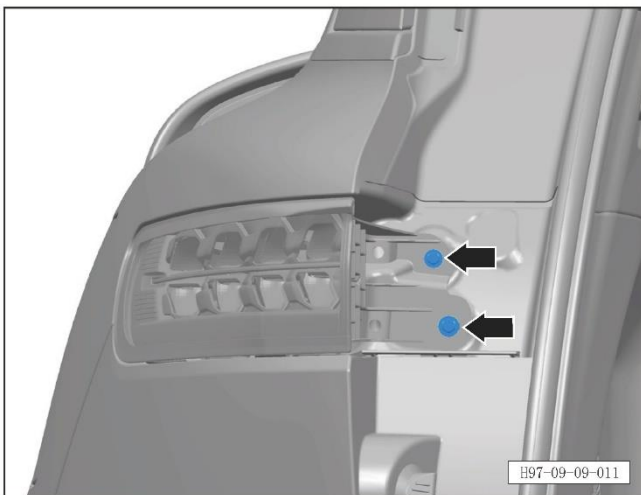

b. Unscrew 1 fixing bolt on the left rear combination lamp fixed side.

Tightening torque of bolt: $8\pm 1\text{Nm}$.

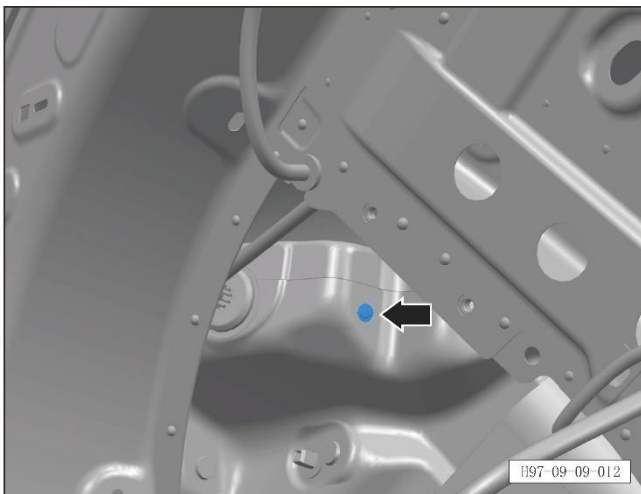

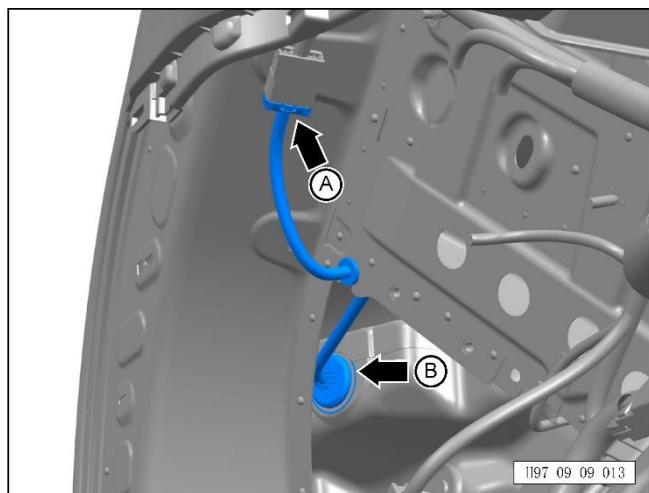

c. Disconnect the connector A of the left rear combination lamp fixed side and disengage the harness sheath B of the left rear combination lamp fixed side.

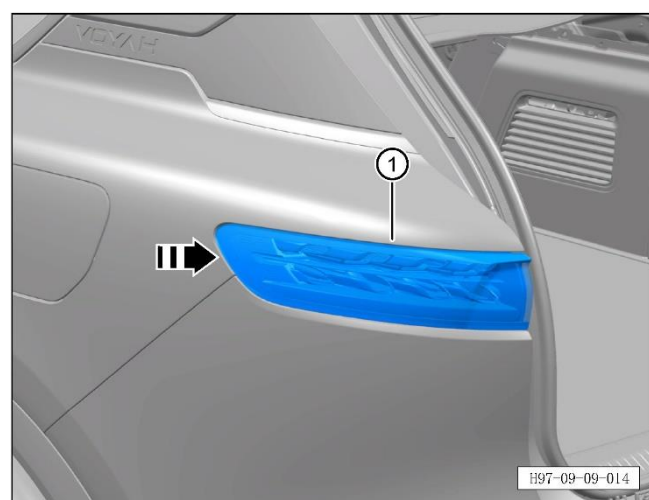

D. Disengage the stopper of the left rear combination lamp fixed side backward as indicated by the arrow to remove the left rear combination lamp fixed side ①.

Refitting procedure

The refitting procedure is performed in reverse order.

CAUTION:

- When refitting the harness sheath of the left rear combination lamp fixed side, arrange the harness sheath so that it is fixed and fits well with the body hole to prevent water leakage.

9.9.4.2 Removal and refitting of rear combination lamp fixed side plate

Removal procedure

Note:

- The following is the removal and refitting of the left rear combination lamp fixed side plate, which can be referred to for the operations on the right rear side.

1. Open the tailgate.
2. Remove the left rear combination lamp fixed side plate.

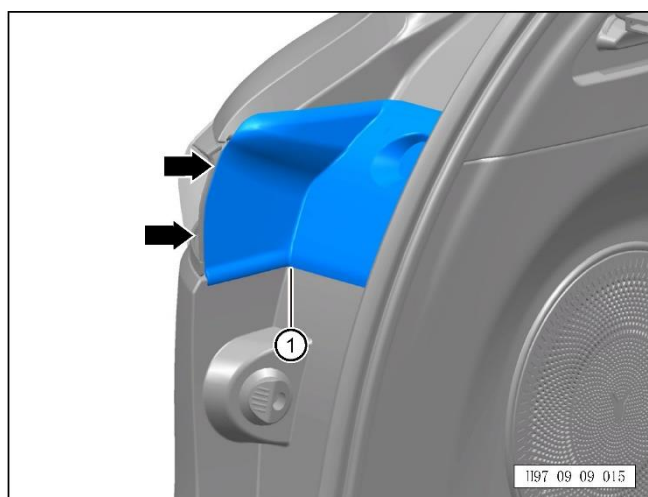

- a. Disengage 2 fixing clips of the left rear combination lamp fixed side plate to remove the left rear combination lamp fixed side plate ①.

Refitting procedure

The refitting procedure is performed in reverse order.

9.9.4.3 Removal and refitting of rear combination lamp movable side plate

Removal procedure

Note:

- The following is the removal and refitting of the side plate of rear combination lamp movable side, which can be referred to for the operations on the right side.

1. Open the tailgate.
2. Remove the left side plate of the rear combination lamp movable side.

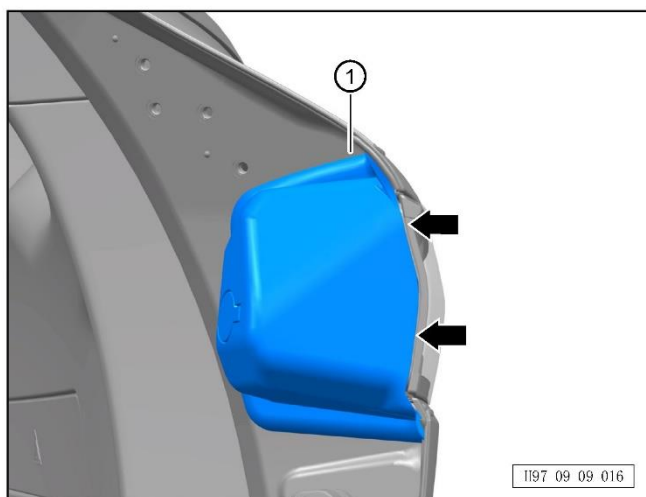

- a. Disengage 2 fixing clips of the side plate of the rear combination lamp movable side to remove the side plate ① of the rear combination lamp movable side.

Refitting procedure

The refitting procedure is performed in reverse order.

9.9.4.4 Removal and refitting of rear combination lamp movable side

Removal procedure

1. Turn off all electrical appliances and the start switch.
2. Disconnect the negative terminal of the battery (refer to [3.1.7.1 Maintenance and inspection of battery](#))
3. Remove the left and right side plates of the rear combination lamp movable side (refer to [9.9.4.3 Removal and refitting of rear combination lamp movable side plate](#))
4. Remove the tailgate lower trim panel assembly (refer to [8.4.4.4 Removal and refitting of tailgate lower trim panel assembly](#))
5. Remove the rear combination lamp movable side.
 - a. Disconnect the connector of the rear combination lamp movable side.

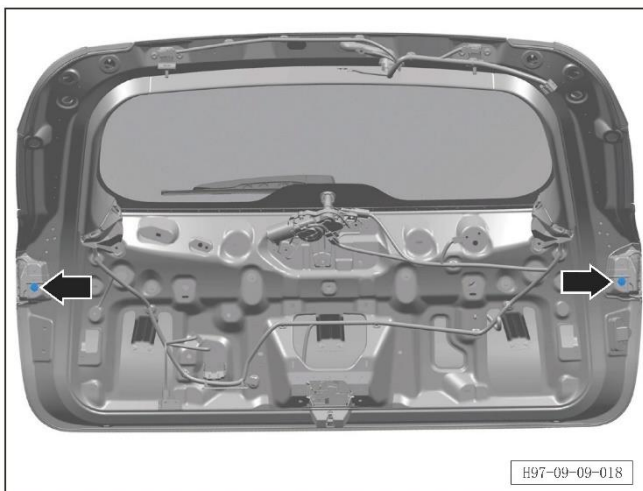

- b. Unscrew 2 fixing bolts of the rear combination lamp movable side.

Tightening torque of bolt: $8\pm 1\text{Nm}$.



c. Unscrew 6 fixing nuts of the rear combination lamp movable side.

Tightening torque of nut: $8\pm 1\text{Nm}$.

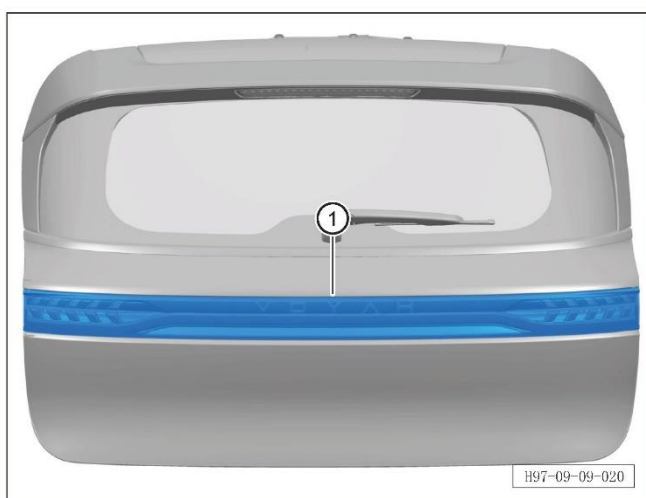

d. Remove the rear combination lamp movable side ①.

Refitting procedure

The refitting procedure is performed in reverse order.

9.9.5 3rd brake lamp (or high-mounted brake lamp)

9.9.5.1 Removal and refitting of 3rd brake lamp

Removal procedure

1. Turn off all electrical appliances and the start switch.
2. Disconnect the negative terminal of the battery (refer to [3.1.7.1 Maintenance and inspection of battery](#))
3. Remove the rear deflector assembly (refer to [8.6.6.8 Removal and refitting of rear deflector assembly](#))
4. Remove the 3rd brake lamp.
 - a. Disengage 2 plugs of the rear deflector assembly.

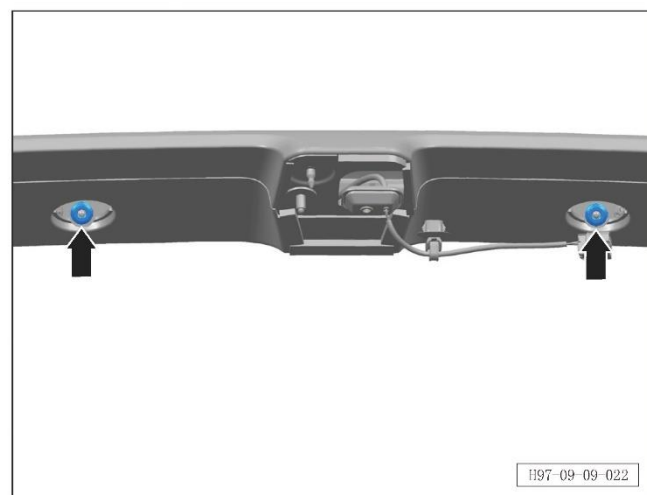
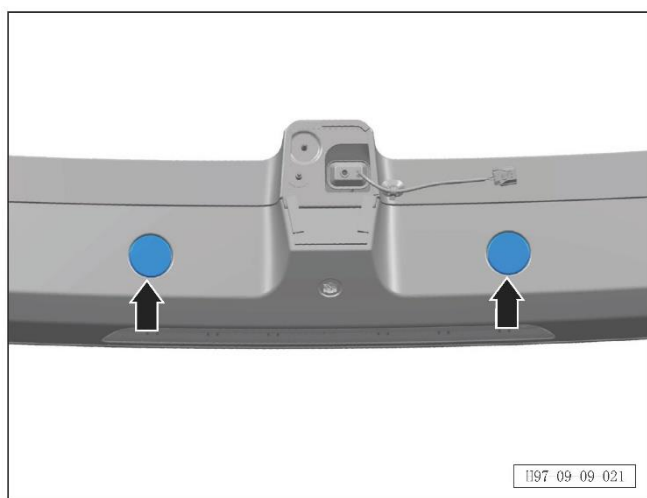

- b. Unscrew 2 fixing bolts of the 3rd brake lamp.
Tightening torque of bolt: $8\pm 1\text{Nm}$.

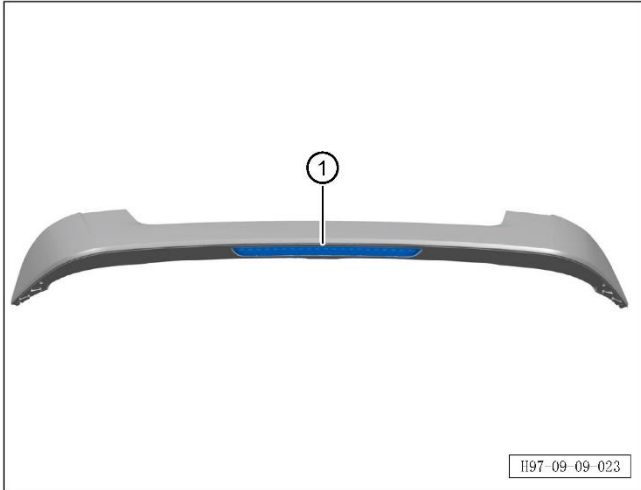

c. Remove the 3rd brake lamp ①.

Refitting procedure

The refitting procedure is performed in reverse order.

9.9.6 License plate lamp

9.9.6.1 Removal and refitting of license plate lamp

Removal procedure

Note:

- The following is the removal and refitting of the left license plate lamp, which can be referred to for the operations on the right side.

1. Turn off all electrical appliances and the start switch.
2. Disconnect the negative terminal of the battery (refer to [3.1.7.1 Maintenance and inspection of battery](#))
3. Remove the rear bumper assembly (refer to [8.6.3.10 Removal and refitting of rear bumper assembly](#))
4. Remove the left license plate lamp.

a. Disconnect the connector of the left license plate lamp.

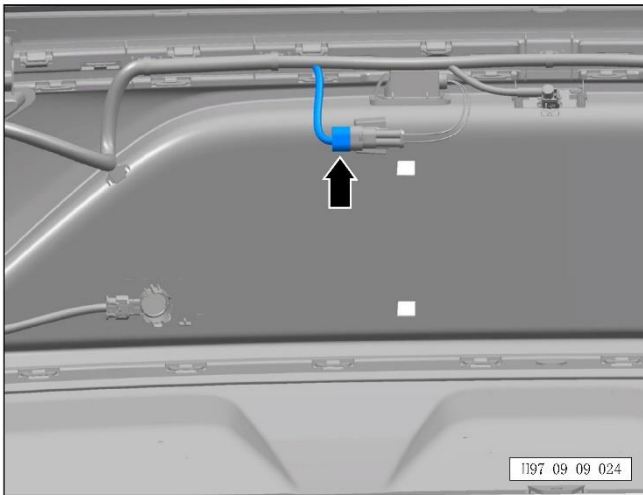

b. Disengage the fixing clip A of the left license plate lamp connector and the fixing clip B of the left license plate lamp.

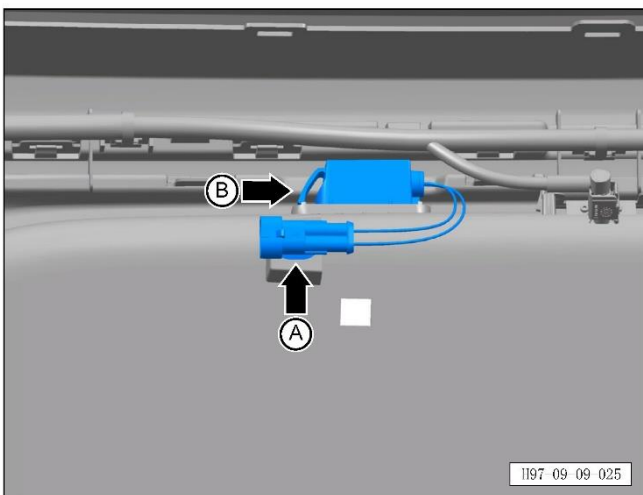

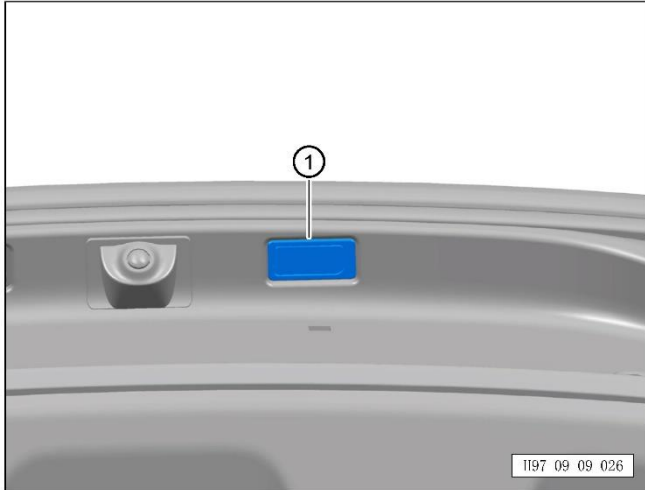

c. Remove the left license plate lamp ①.

Refitting procedure

The refitting procedure is performed in reverse order.

9.9.7 Rear fog lamp and side turn signal lamp

9.9.7.1 Removal and refitting of rear fog lamp

Removal procedure

Note:

- The following is the removal and refitting of the left rear fog lamp, which can be referred to for the operations on the right rear side.

1. Turn off all electrical appliances and the start switch.
2. Disconnect the negative terminal of the battery (refer to [3.1.7.1 Maintenance and inspection of battery](#))
3. Remove the rear bumper assembly (refer to [8.6.3.10 Removal and refitting of rear bumper assembly](#))
4. Remove the left rear fog lamp.
 - a. Disconnect the connector of the rear fog lamp.

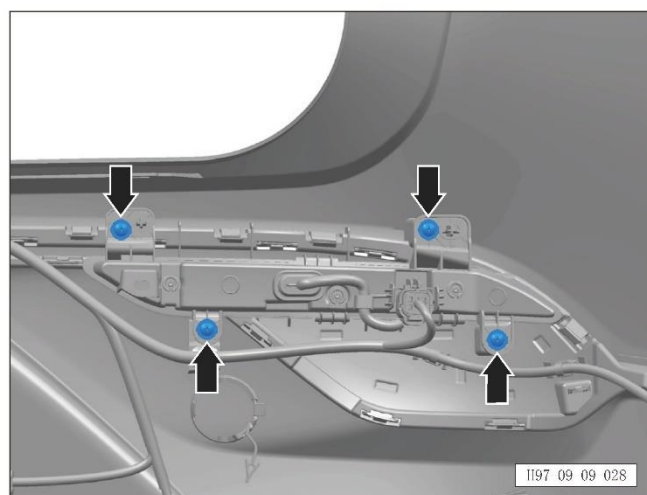
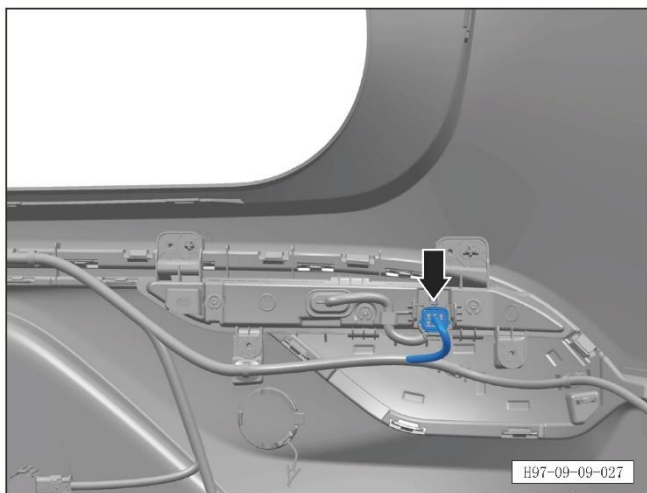

- b. Unscrew 4 fixing screws of the rear fog lamp.
Tightening torque of screw: $2.5 \pm 0.5 \text{ Nm}$

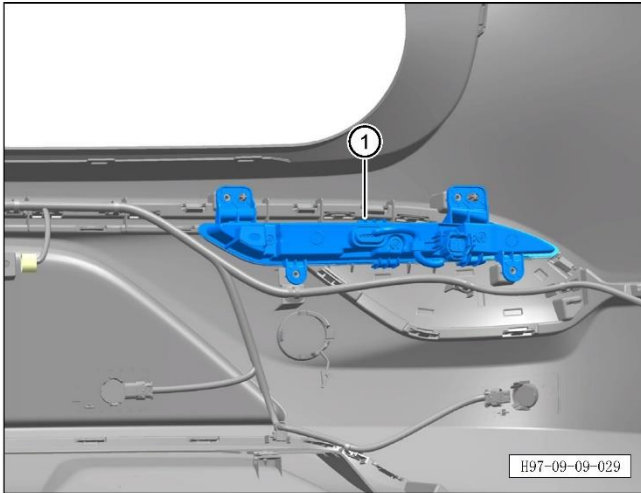

c. Remove the rear fog lamp ①.

Refitting procedure

The refitting procedure is performed in reverse order.

9.9.7.2 Removal and refitting of side turn signal lamp

Removal procedure

Note:

- The following is the removal and refitting of the left turn signal lamp, which can be referred to for the operations on the right side.

1. Turn off all electrical appliances and the start switch.
2. Disconnect the negative terminal of the battery (refer to [3.1.7.1 Maintenance and inspection of battery](#))
3. Remove the left exterior rearview mirror lens (refer to [8.6.8.6 Removal and refitting of exterior rearview mirror lens](#))
4. Remove the left turn signal lamp.

4. Remove the left turn signal lamp.

- a. Unscrew 4 fixing screws of the rearview mirror cover.

Tightening torque of screw: $2.5 \pm 0.5 \text{ Nm}$

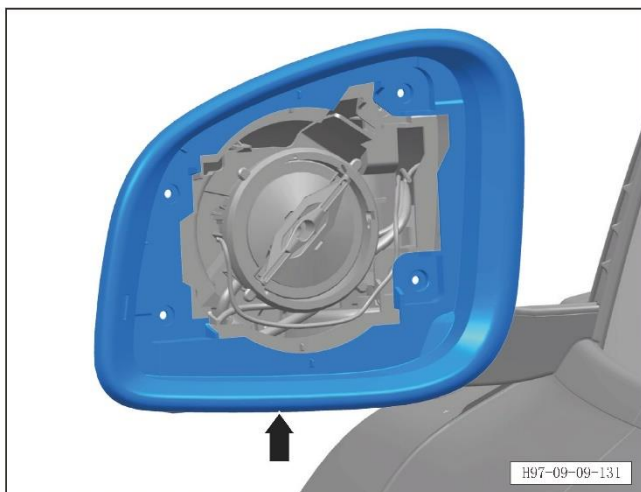
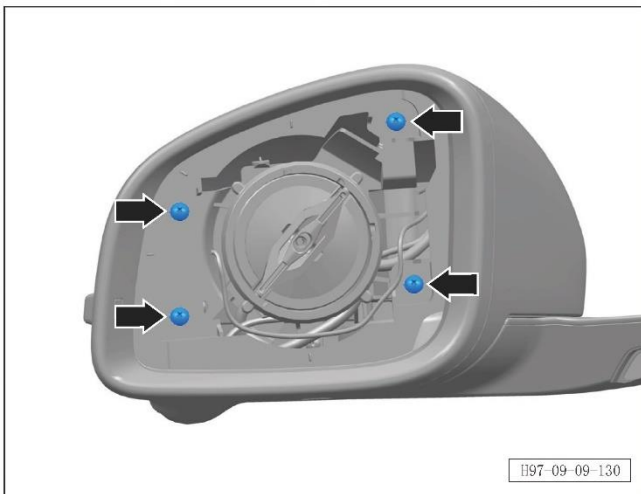

- b. Remove the rearview mirror cover.

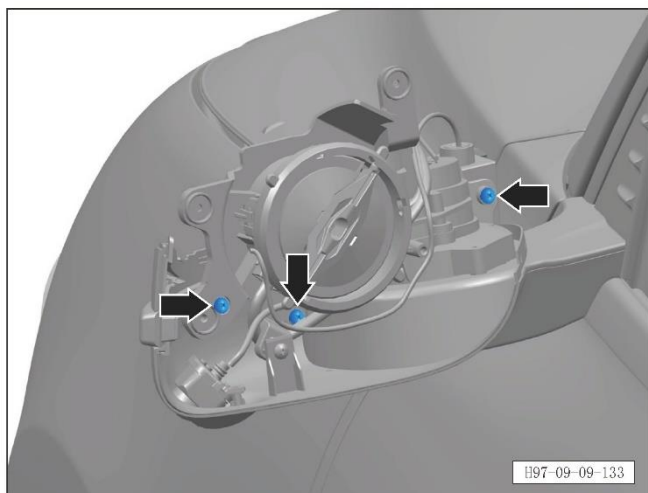

c. Unscrew 3 fixing screws of the left turn signal lamp.
Tightening torque of screw: $2.5 \pm 0.5 \text{ Nm}$

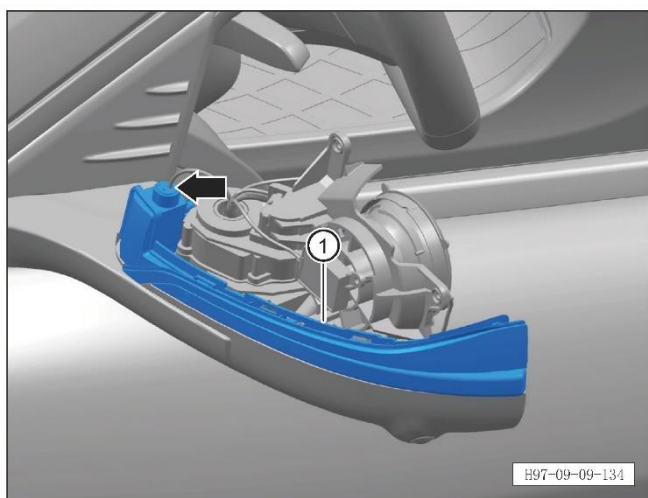

d. Disengage the waterproof plug of the left turn signal lamp connector, and disconnect the connector to remove the left turn signal lamp ①.

Refitting procedure

The refitting procedure is performed in reverse order.

9.9.8 Ambient lamp

9.9.8.1 Removal and refitting of door handle ambient lamp

Removal procedure

Note:

- The following is the removal and refitting of the left door handle ambient lamp, which can be referred to for the operations on the right door and rear door.

1. Turn off all electrical appliances and the start switch.
2. Disconnect the negative terminal of the battery (refer to [3.1.7.1 Maintenance and inspection of battery](#))
3. Remove the front door outside handle housing (refer to [7.2.4.5 Removal and refitting of front door outside handle housing](#))
4. Remove the left front door trim panel assembly (refer to [8.4.1.1 Removal and refitting of front door trim panel assembly](#))
5. Remove the front door front waterproof membrane (refer to [7.2.4.11 Removal and refitting of front door front waterproof membrane](#))
6. Remove the front door outside handle (refer to [7.2.4.4 Removal and refitting of front door outside handle](#))
7. Remove the left door handle ambient lamp.

a. Unscrew 7 fixing screws of the left door handle ambient lamp.

Tightening torque of screw: $2.5 \pm 0.5 \text{ Nm}$

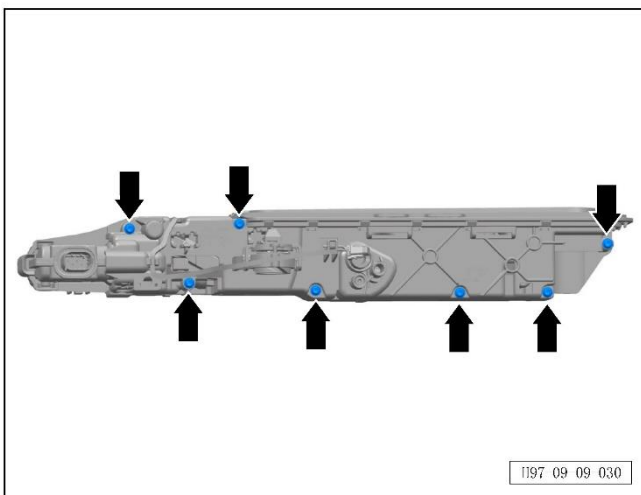

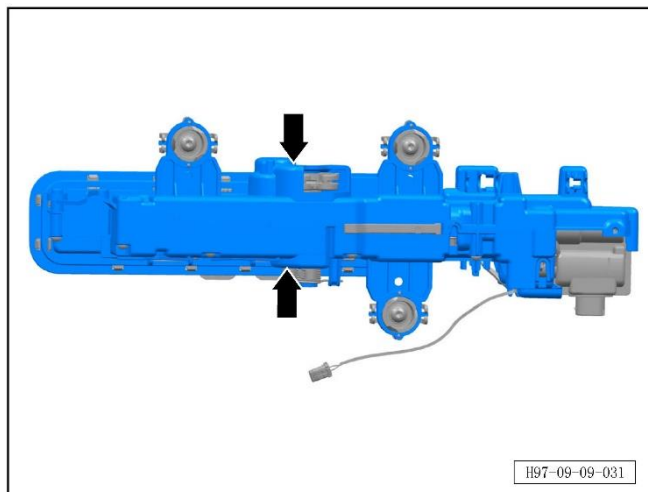

b. Remove the upper and lower covers of the front door outside handle.

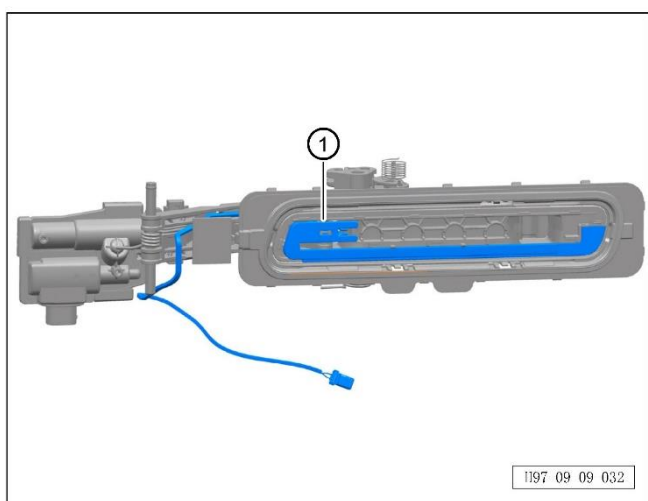

c. Take out the left door handle ambient lamp ①.

Refitting procedure

The refitting procedure is performed in reverse order.

9.9.8.2 Removal and refitting of IP ambient lamp control module

Removal procedure

1. Turn off all electrical appliances and the start switch.
2. Disconnect the negative terminal of the battery (refer to [3.1.7.1 Maintenance and inspection of battery](#))
3. Remove the right trim panel assembly (refer to [8.2.4.19 Removal and refitting of right trim panel assembly](#))
4. Remove the IP ambient lamp control module.

a. Unscrew 2 fixing screws of the IP ambient lamp control module.

Tightening torque of screw: $1\pm 0.2\text{Nm}$

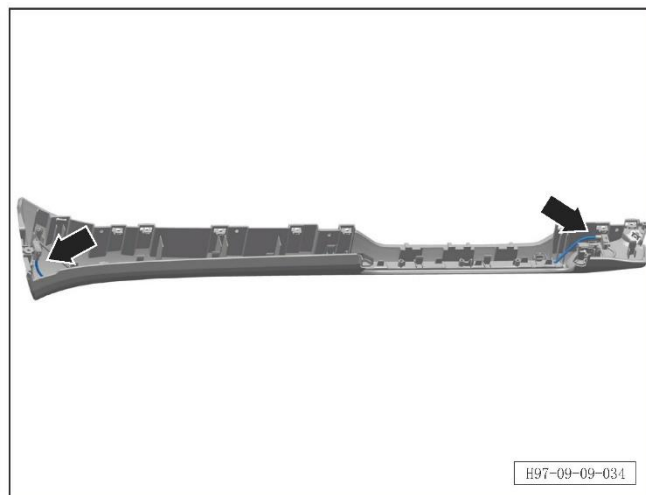
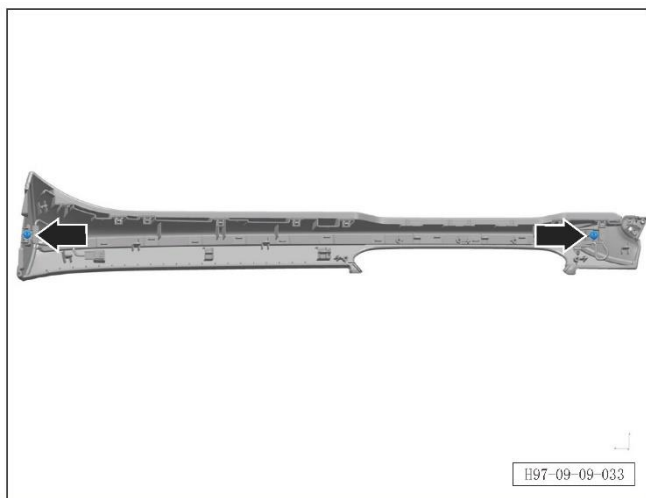

b. Disconnect the ambient lamp control module from the ambient lamp.

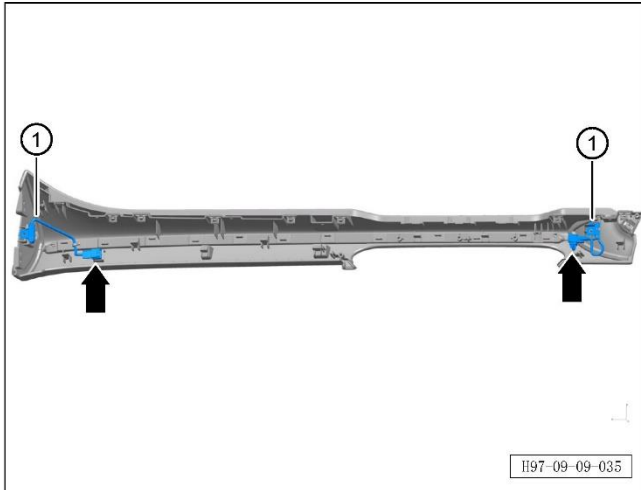

c. Disconnect 2 fixing clips of the ambient lamp control module connector to remove the ambient lamp control module ①.

Refitting procedure

The refitting procedure is performed in reverse order.

9.9.8.3 Removal and refitting of door ambient lamp control module

Removal procedure

Note:

- The following is the removal and refitting of the left front door ambient lamp control module, which can be referred to for the operations on the right door and rear door.

1. Turn off all electrical appliances and the start switch.
2. Disconnect the negative terminal of the battery (refer to [3.1.7.1 Maintenance and inspection of battery](#))
3. Remove the left front door trim panel assembly (refer to [8.4.2.1 Removal and refitting of front door trim panel assembly](#))
4. Remove the left front door ambient lamp control module.

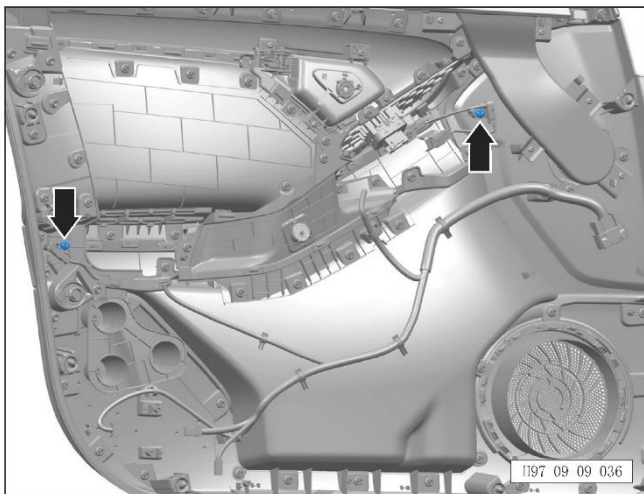

- a. Unscrew 2 fixing screws of the left front door ambient lamp control module.

Tightening torque of screw: $1\pm 0.2\text{Nm}$

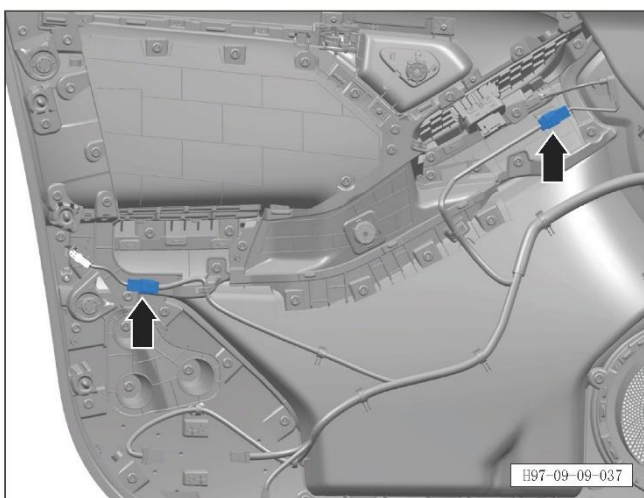

- b. Disconnect 2 connectors of the ambient lamp control module, and disengage 2 fixing clips of the ambient lamp control module.

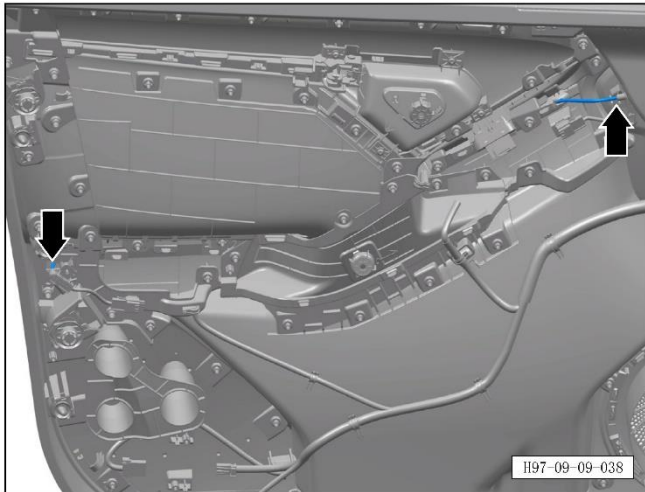

c. Disconnect the ambient lamp control module from the ambient lamp.

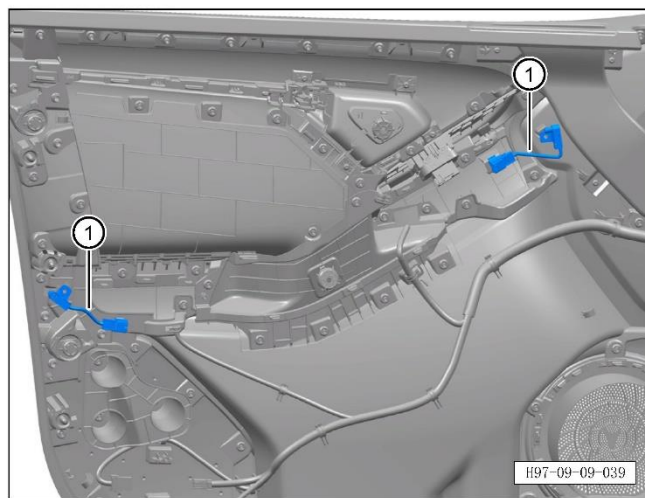

d. Remove the left front door ambient lamp control module ①.

Refitting procedure

The refitting procedure is performed in reverse order.

9.9.8.4 Removal and refitting of point light source

Removal procedure

Note:

- The following is the removal and refitting of the IP right lower point light source, which can be referred to for the operations on other positions.

1. Turn off all electrical appliances and the start switch.
2. Disconnect the negative terminal of the battery (refer to [3.1.7.1 Maintenance and inspection of battery](#))
3. Remove the instrument panel right lower point light source.

a. Disengage 3 fixing clips of the point light source.

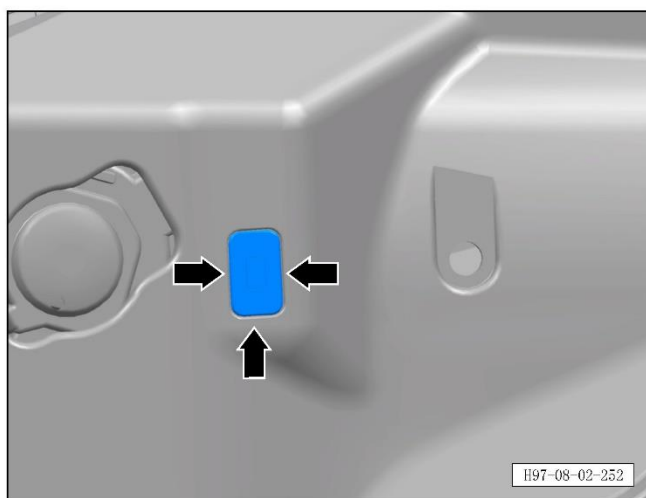

b. Disconnect the connectors of the point light source and take out the point light source ①.

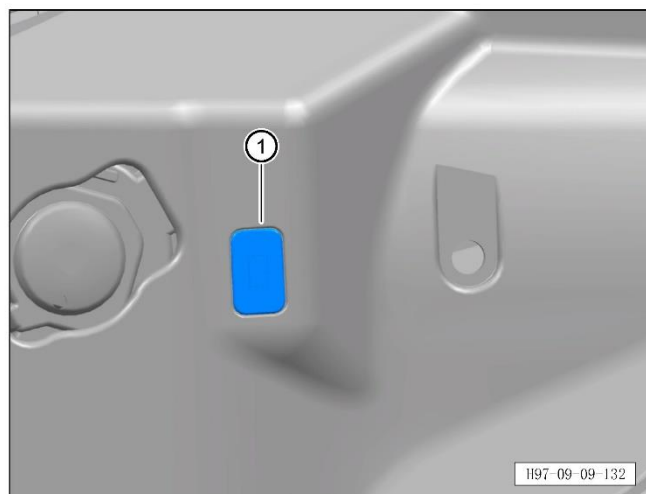

Refitting procedure

The refitting procedure is performed in reverse order.

9.9.8.5 Removal and refitting of stepless dimming glass controller

Removal procedure

1. Turn off all electrical appliances and the start switch.
2. Disconnect the negative terminal of the battery (refer to [3.1.7.1 Maintenance and inspection of battery](#))
3. Remove the rear of the roof inner trim panel assembly (refer to [8.5.6.1 Removal and refitting of roof inner trim panel assembly](#))
4. Remove the stepless dimming glass controller.

- a. Unscrew 2 fixing bolts of the stepless dimming glass controller.

Tightening torque of bolt: $9\pm 2\text{Nm}$.

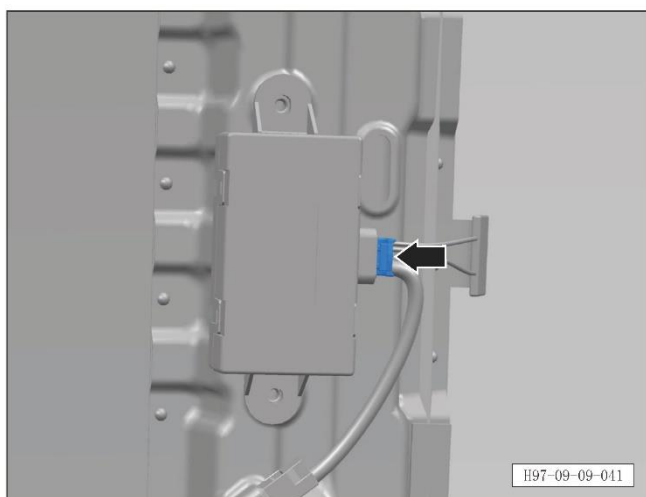
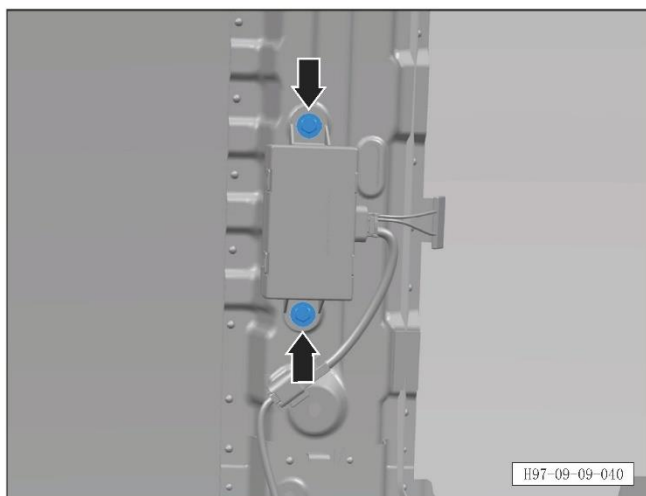

- b. Disconnect the connector of the stepless dimming glass controller.

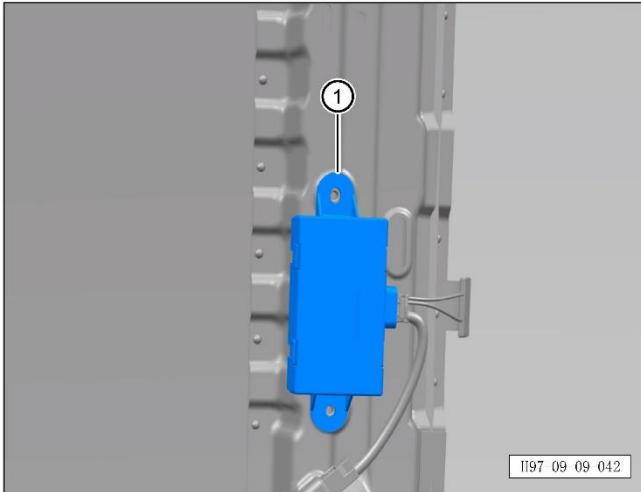

c. Take out the stepless dimming glass controller.

Refitting procedure

The refitting procedure is performed in reverse order.

9.9.9 Front door floor lamp

9.9.9.1 Removal and refitting of front door floor lamp

Removal procedure

Note:

- The following is the removal and refitting of the left front door floor lamp, which can be referred to for the operations on the right front side.

1. Turn off all electrical appliances and the start switch.
2. Disconnect the negative terminal of the battery (refer to [3.1.7.1 Maintenance and inspection of battery](#))
3. Remove the left front door trim panel assembly (refer to [8.4.2.1 Removal and refitting of front door trim panel assembly](#))
4. Remove the left front door floor lamp.

a. Unscrew 2 fixing screws of the left front door floor lamp.

Tightening torque of screw: $2.5 \pm 0.5 \text{ Nm}$

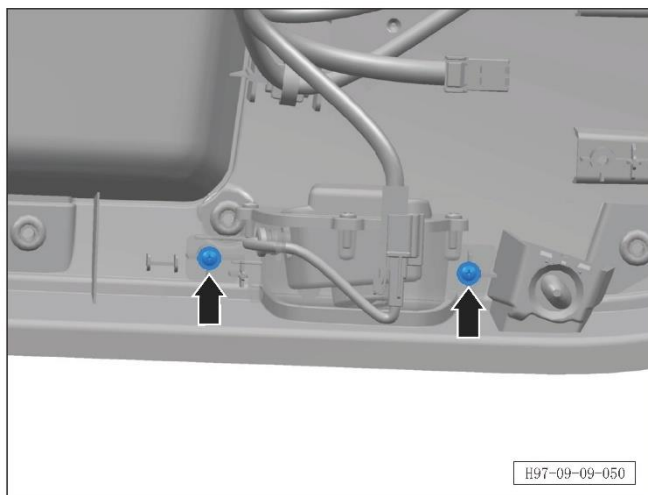

b. Disconnect the connector of the left front door floor lamp and take out the left front door floor lamp ①.

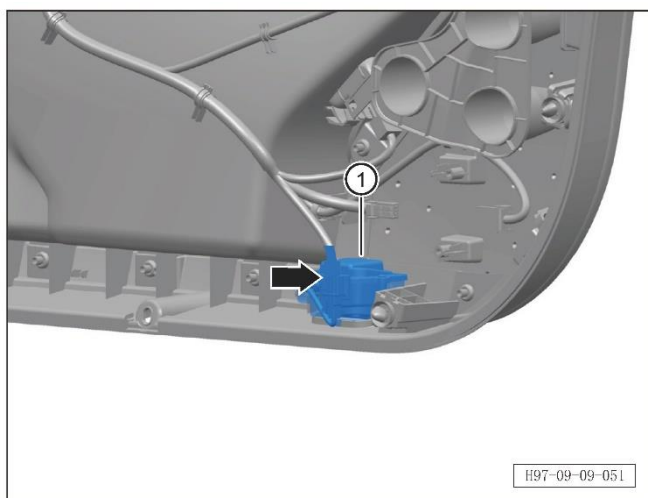

Refitting procedure

The refitting procedure is performed in reverse order.

9.9.10 External charging indicator

9.9.10.1 Removal and refitting of charging indicator

Removal procedure

1. Turn off all electrical appliances and the start switch.
2. Disconnect the negative terminal of the battery (refer to [3.1.7.1 Maintenance and inspection of battery](#))
3. Remove the charging port cover body (refer to [7.6.3.2 Removal and refitting of charging port cover body](#))
4. Remove the charging port cover baffle (refer to [7.6.3.3 Removal and refitting of charging port cover baffle](#))
5. Remove the left rear side wall inner trim panel assembly (refer to [8.5.5.10 Removal and refitting of rear side wall inner trim panel assembly](#))
6. Remove the charging indicator.

- a. Unscrew 2 fixing screws of the charging indicator.
Tightening torque of screw: $3\pm 0.5\text{Nm}$



- b. Disengage 2 fixing clips of the charging indicator.

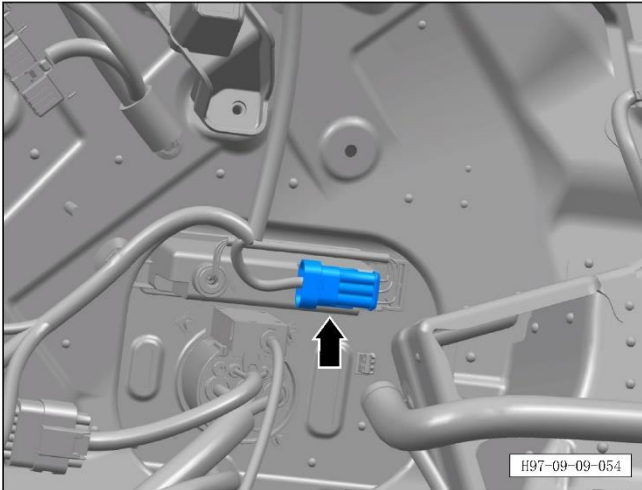

c. Disconnect the connector of the charging indicator.

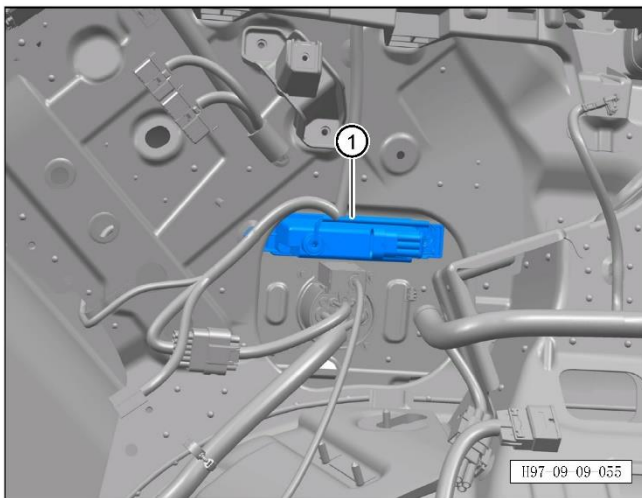

d. Take out the charging indicator ①.

Refitting procedure

The refitting procedure is performed in reverse order.

9.9.11 Interior lamp

9.9.11.1 Removal and refitting of trunk lamp

Removal procedure

Note:

- The following is the removal and refitting of the left trunk lamp, which can be referred to for the operations on the right side.

1. Turn off all electrical appliances and the start switch.
2. Disconnect the negative terminal of the battery (refer to [3.1.7.1 Maintenance and inspection of battery](#))
3. Remove the left trunk lamp.

a. Disengage 2 fixing clips of the left trunk lamp.

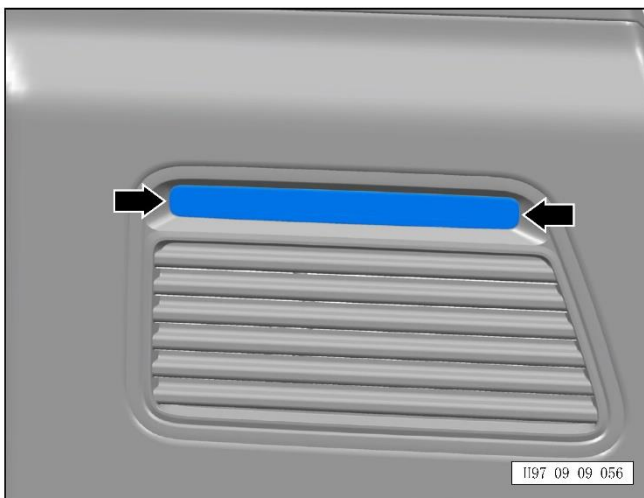

b. Disconnect the connector of the left trunk lamp and take out the left trunk lamp ①.

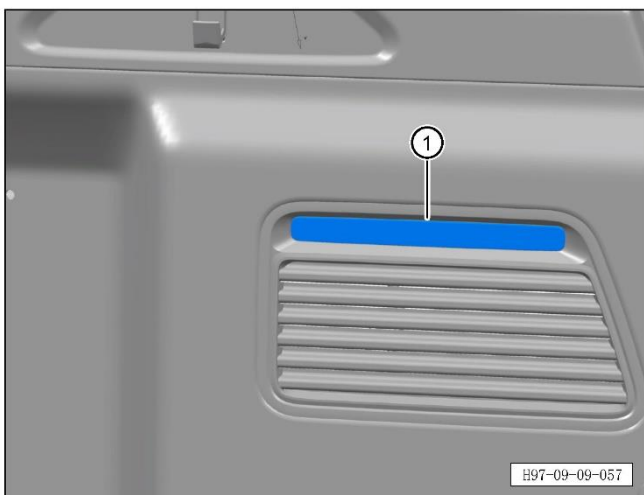

Refitting procedure

The refitting procedure is performed in reverse order.

9.9.11.2 Removal and refitting of front ceiling lamp assembly

Removal procedure

1. Turn off all electrical appliances and the start switch.
2. Disconnect the negative terminal of the battery (refer to [3.1.7.1 Maintenance and inspection of battery](#))
3. Remove the front ceiling lamp assembly.

a. Open the glass box and unscrew 2 fixing screws of the front ceiling lamp assembly.

Tightening torque of screw: $2\pm 0.5\text{Nm}$

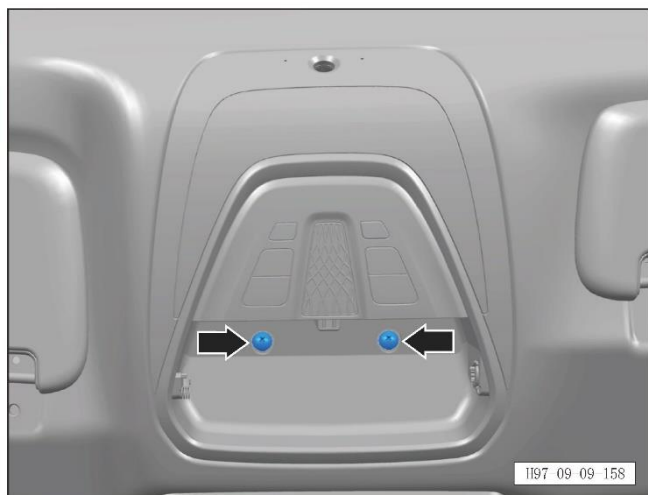

b. Disengage 2 fixing clips of the front ceiling lamp assembly.

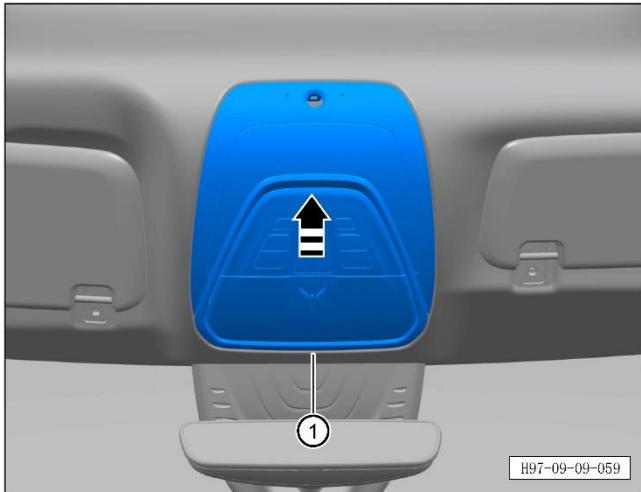

c. Disconnect the front ceiling lamp ① as indicated by the arrow, and disconnect the connector of the front ceiling lamp assembly and of the rear monitoring camera.

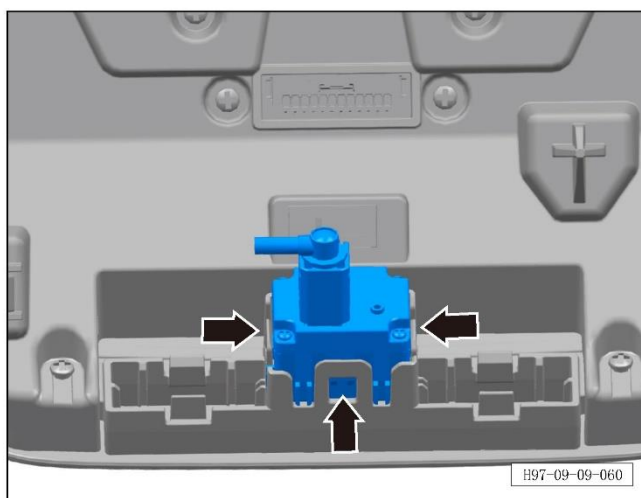

d. Disengage 3 fixing clips of the rear monitoring camera to remove the driving monitoring camera.

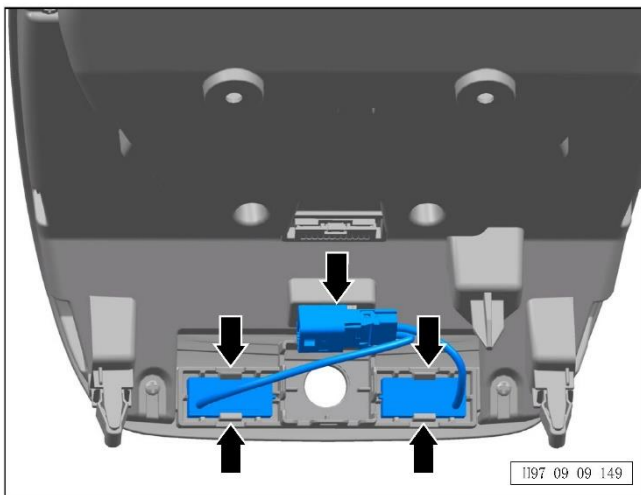

e. Take out 4 fixing clips of the front ceiling lamp and the fixing clip of the dual microphone connector, remove the dual microphone, and take out the front ceiling lamp assembly.

Refitting procedure

The refitting procedure is performed in reverse order.

9.9.11.3 Removal and refitting of rear ceiling lamp

Removal procedure

Note:

- The following is the removal and refitting of the left rear ceiling lamp assembly, which can be referred to for the operations on the right rear side.

1. Turn off all electrical appliances and the start switch.

2. Disconnect the negative terminal of the battery (refer to [3.1.7.1 Maintenance and inspection of battery](#))

3. Remove the left rear ceiling lamp assembly.

a. Disengage 1 fixing clip of the left rear ceiling lamp assembly.

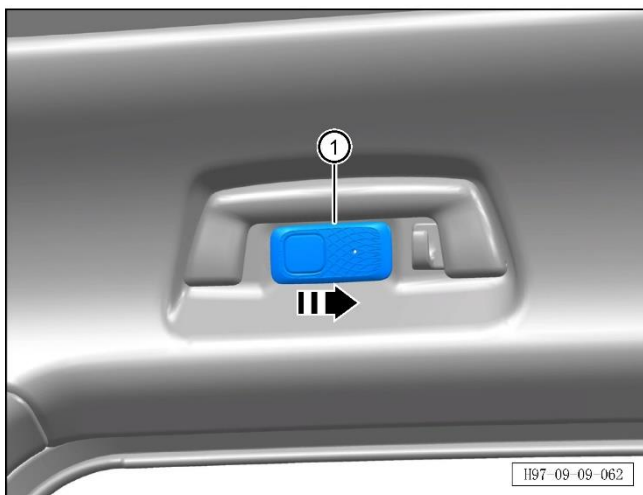
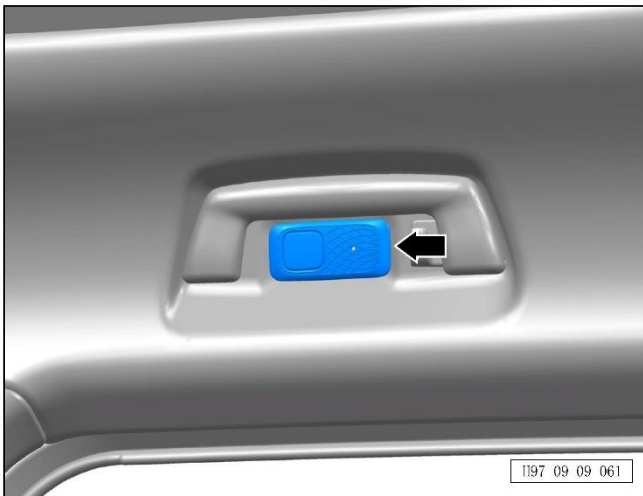

b. Disengage the left rear ceiling lamp ① as indicated by the arrow, and disconnect the connector of the left rear ceiling lamp assembly and of the left single microphone.

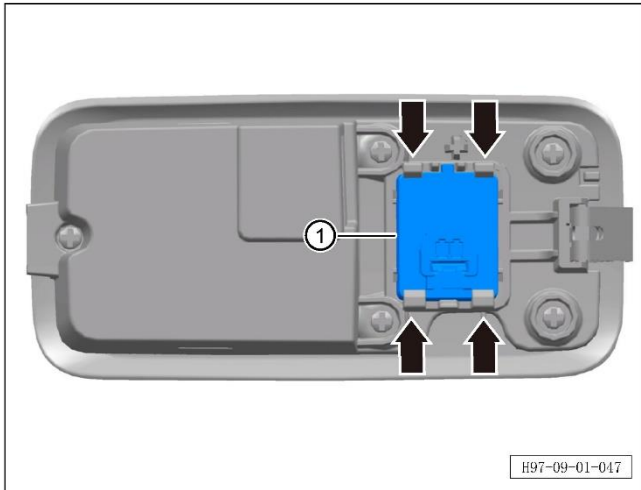

c. Take out 4 fixing clips of the left single microphone, remove the left single microphone, and take out the left rear ceiling lamp assembly ①.

Refitting procedure

The refitting procedure is performed in reverse order.

9.10 Intelligent driving system

9.10.1 Description and operation

Forward MMW radar

The forward MMW radar is refitted in the middle of the front bumper lower grille to monitor traffic conditions and detect vehicles ahead within a certain range of the vehicle. No other obstacles are allowed in the field of view of the forward MMW radar. When refitting the front license plate, do not refit a large license plate frame that may block the forward MMW radar, otherwise the forward MMW radar will be blocked, causing the function failure of ACC system and the FCWS, ABA system and pedestrian detection. The radar sensor must be adjusted and calibrated under the following conditions:

- The mounting and positioning brackets for the radar sensor have been removed and refitted;
- The radar sensor has been removed and refitted;
- The toe-in or rear-wheel camber has been adjusted during four wheel alignment;
- After a vehicle collision.

CAUTION!

- If the radar sensor is damaged or the direction changes, please turn off the radar-related functions (ACC, FCWS, ABA, etc.), and it is recommended to go to an authorized VOYAH Service Center in time to recalibrate the radar sensor.

Smart forward camera

The FVC sensor is refitted on the upper part of the windshield, and no other obstacles are allowed in the camera sensor's field of view.

An intelligent forward camera is refitted on the upper part of the front windshield to detect the surrounding environment and matters. The maximum pedestrian recognition distance is about 80 m (under ideal circumstances such as lighting and other ambient factors) when no obstacle is found, and the minimum detection height of the pedestrian on the camera is 0.8 m.

The FVC sensor must be calibrated under following situations:

- The front windshield or camera has been removed and replaced;
- The bracket has been removed and the FVC sensor has been replaced.

CAUTION!

- Poor lighting conditions, nighttime, backlight, and heavy rain may affect the smart forward camera, resulting in ACC, FCW, ABA system, lane departure assist system and IHBC to be interrupted or their performance degradation. In serious conditions, the functions will be disabled completely, and intelligent driving assistance alarm information such as "Please check the lane departure assist system", "Please check the ACC ", "Please check the FCW", "Please check the ABA system", "Pedestrian detection system unavailable" will appear on instrument.

- The camera cannot recognize animals and short pedestrians;
- Before driving, please confirm whether there is a block in the camera area;
- Keep the clear view of the intelligent forward camera sensor.

Reversing/parking aid

The RPA measures the distance between the vehicle and the obstacle by sending and receiving the ultrasonic wave reflected from the obstacle by the radar sensor.

CAUTION!

- The surface of the radar sensor shall always be kept clean. When cleaning the surface of the radar sensor, a soft damp cloth shall be used to avoid scratching the surface;
- The RPA cannot replace the driver's observation of the surrounding environment. The driver shall concentrate on reversing and adjusting the parking space safely according to the actual situations;
- When reversing in narrow places or uphill, the radar sensor may not detect railings, trees or slopes, which is normal.

Backup camera

The RVC is located next to the license plate lamp.

The reversing rearview image can provide a 360° wide-angle video, which can display a wide range of rear video images on CSD, allowing the driver to grasp various complex road conditions behind the vehicle and improve the safety of reversing.

Rear view system ON/OFF

- When switching to "R" gear, the reversing rearview system automatically starts to work, and the image system display starts to display the rear shooting screen, and the reversing auxiliary line is displayed on the screen;
- When switching from "R" gear, the reversing rearview system will automatically exit, and the image system will exit the reversing screen display.

Warning!

- As the RVC has certain blind spots, it may not find children or small pets. When reversing, you must pay special attention to the surroundings.

AVM system

The AVM can assist the driver to complete automatic parking in and out. The system consists of a control host module and four 180° cameras. It take pictures of the surrounding environment of the vehicle, and displays it through the CSD, which provides the driver with the real-time information about the surrounding environment of the vehicle. It assists the driver to safely pass through complex road conditions or park in a space.

AVM ON/OFF

1. It can be turned on/off by switching the gears. When the engine start/stop button is in "ON" position:
 - When switching to "R" position, the AVM is automatically turned on;
 - When switching from "R" and the driver has no relevant operations, the AVM will display for 5 s and then automatically exit.
2. It can be turned on/off by pressing the button. When the engine start/stop button is in "ON" position:
 - Press and release the button, the button lamp will be illuminated, and the AVM will be turned on;
 - Press and release the button again, the button lamp will go out, and the AVM will be turned off.
3. On the "Vehicle control" interface of the CSD, you can choose to turn on/off the "Turn signal lamp triggers AVM" function. After the function is turned on and the driver turns on the turn signal lamp, the AVM will be automatically turned on.

9.10.2 Position diagram of parts

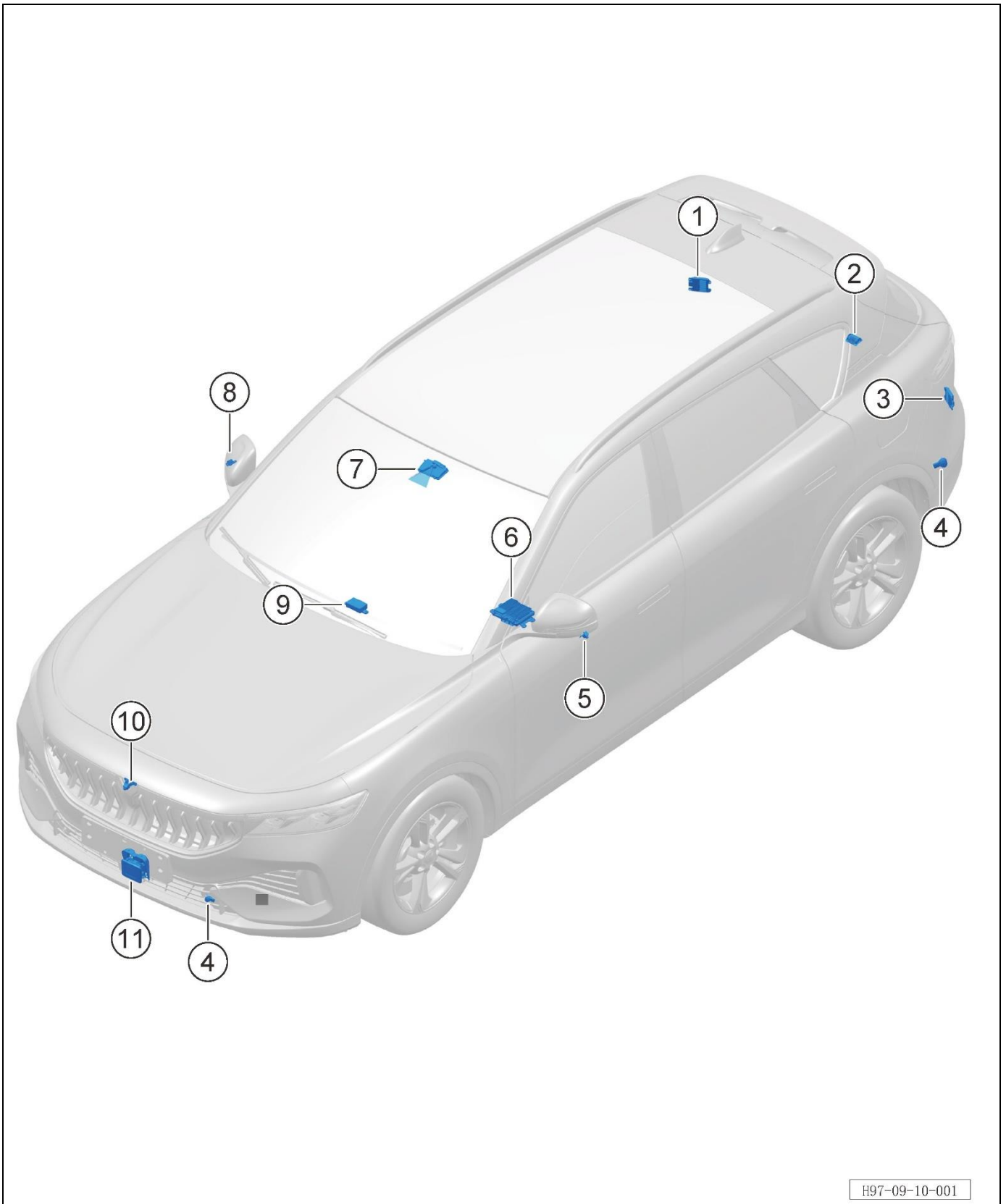

H97-09-10-001

S/N	Part name	Loading quantity	Remarks
1	Right corner radar	1	
2	RVC	1	
3	Left corner radar	1	
4	RPA	12	
5	Left camera	1	
6	AVM ECU	1	
7	Forward-looking monocular camera	1	
8	Right camera	1	
9	RPA ECU	1	
10	FVC	1	
11	Forward MMW radar	1	

9.10.3 Advanced driving and parking assist

9.10.3.1 Removal and refitting of MMW radar mounting bracket

Removal procedure

1. Turn off all electrical appliances and the start switch.
2. Disconnect the negative terminal of the battery (refer to [3.1.7.1 Maintenance and inspection of battery](#))
3. Remove the front bumper assembly (refer to [8.6.3.3 Removal and refitting of front bumper assembly](#))
4. Remove the MMW radar mounting bracket.

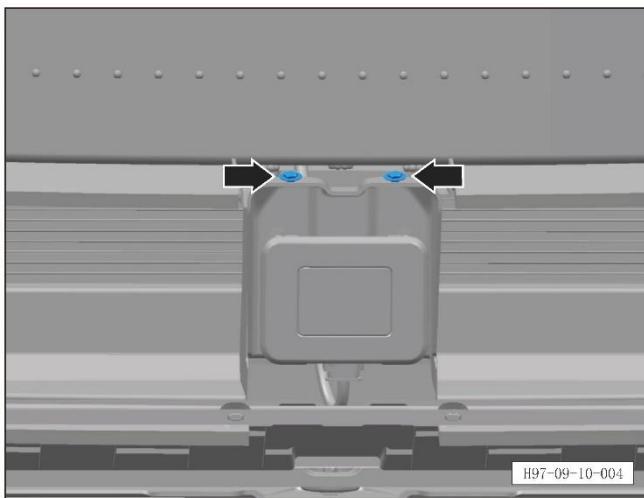

- a. Unscrew 2 fixing bolts of the MMW radar mounting bracket.

Tightening torque of bolt: $10\pm 2\text{Nm}$.

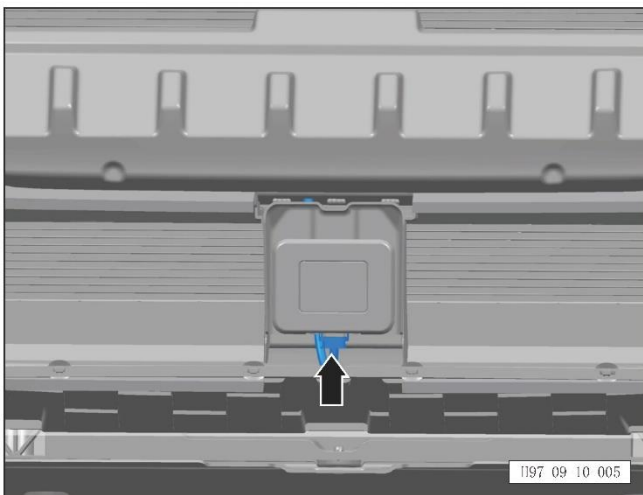

- b. Disconnect the connectors of the MMW radar to remove the assembly of the MMW radar and the MMW radar mounting bracket.



b. Disengage 3 mounting clips of the MMW radar.

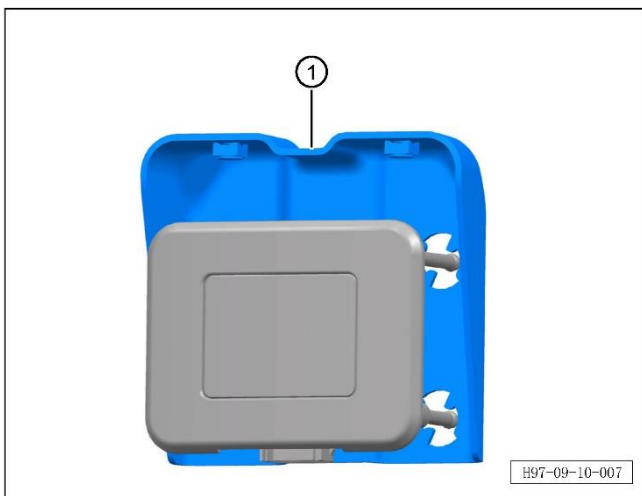

c. Remove the MMW radar mounting bracket ①.

Refitting procedure

The refitting procedure is performed in reverse order.

9.10.3.2 Removal and refitting of MMW radar trim panel assembly

Removal procedure

1. Turn off all electrical appliances and the start switch.
2. Disconnect the negative terminal of the battery (refer to [3.1.7.1 Maintenance and inspection of battery](#))
3. Remove the front bumper assembly (refer to [8.6.3.3 Removal and refitting of front bumper assembly](#))
4. Remove the MMW radar trim cover assembly.

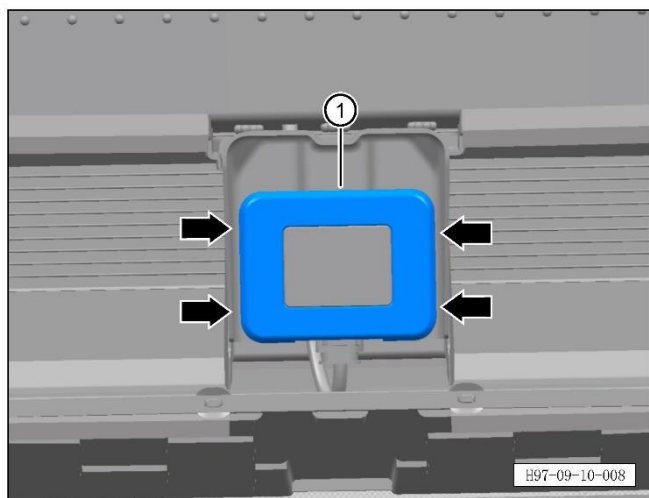

- a. Disengage 4 clips of the MMW radar trim cover assembly to remove the MMW radar trim cover assembly ①.

Refitting procedure

The refitting procedure is performed in reverse order.

9.10.3.3 Removal and refitting of forward MMW radar

Removal procedure

1. Turn off all electrical appliances and the start switch.
2. Disconnect the negative terminal of the battery (refer to [3.1.7.1 Maintenance and inspection of battery](#))
3. Remove the front bumper assembly (refer to [8.6.3.3 Removal and refitting of front bumper assembly](#))
5. MMW radar trim cover assembly (refer to [9.10.3.2 Removal and refitting of MMW radar trim cover assembly](#))
4. Remove the assembly of the MMW radar and the MMW radar mounting bracket (refer to [9.10.3.1 Removal and refitting of MMW radar mounting bracket](#))
6. Remove the forward MMW radar.
 - a. Disengage 3 mounting clips of the MMW radar trim cover assembly.

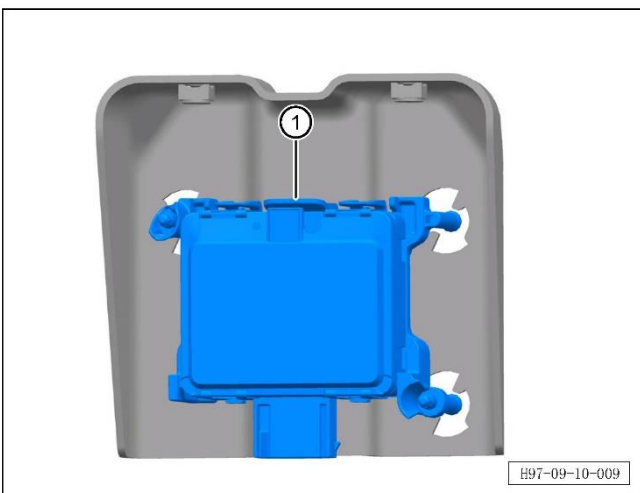
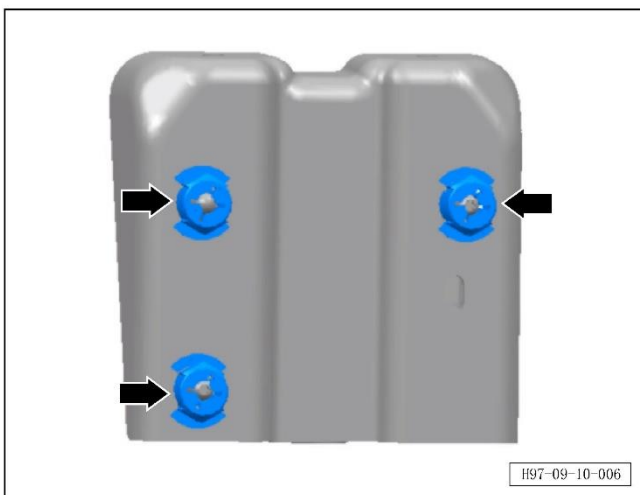

- b. Remove the forward MMW radar ①.

Refitting procedure

The refitting procedure is performed in reverse order.

9.10.3.4 Removal and refitting of rear corner radar

Removal procedure

Note:

- The following is the removal and refitting of the left rear corner radar, which can be referred to for the operations on right rear side.

1. Turn off all electrical appliances and the start switch.
2. Disconnect the negative terminal of the battery (refer to [3.1.7.1 Maintenance and inspection of battery](#))
3. Remove the rear bumper assembly (refer to [8.6.3.10 Removal and refitting of rear bumper assembly](#))
4. Remove the left rear corner radar.

a. Unscrew 3 fixing nuts of the left rear corner radar.

Tightening torque of nut: $10\pm 2\text{Nm}$.

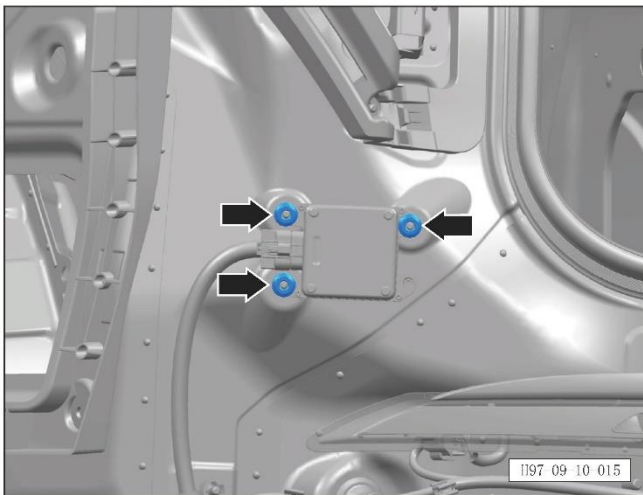

b. Disconnect the connector of the left rear corner radar.

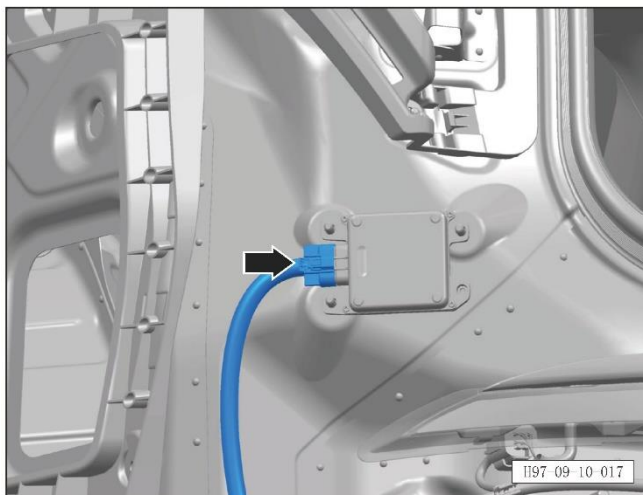

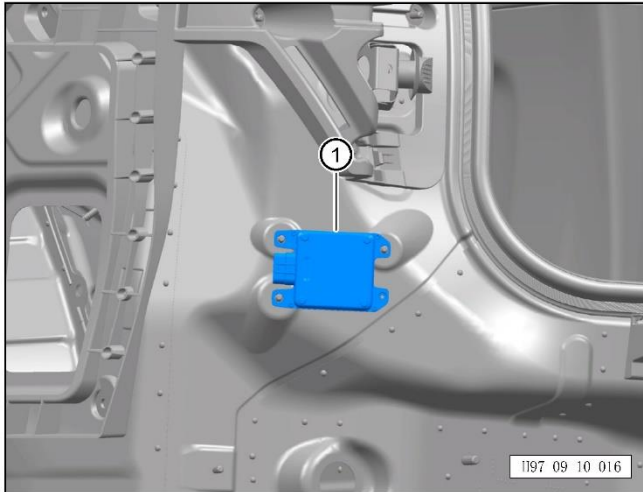

c. Remove the left rear corner radar ①.

Refitting procedure

The refitting procedure is performed in reverse order.

9.10.3.5 Removal and refitting of RPA sensor

Removal procedure

Note:

- The following is the removal and refitting of the rear bumper left RPA sensor, which can be referred to for the operations on other positions.

1. Turn off all electrical appliances and the start switch.
2. Disconnect the negative terminal of the battery (refer to [3.1.7.1 Maintenance and inspection of battery](#))
3. Remove the rear bumper assembly (refer to [8.6.3.10 Removal and refitting of rear bumper assembly](#))
4. Remove the rear bumper left RPA sensor.

a. Disconnect the connector of the rear bumper left RPA sensor.

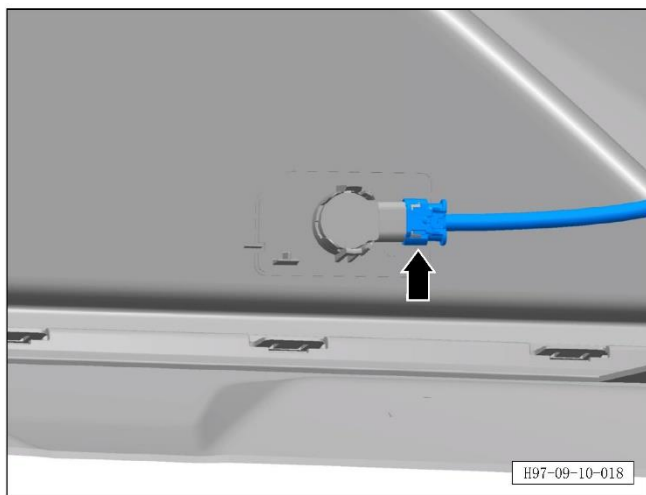

b. Take out 2 fixing clips of the rear bumper left RPA sensor, and take out the rear bumper left RPA sensor ①.

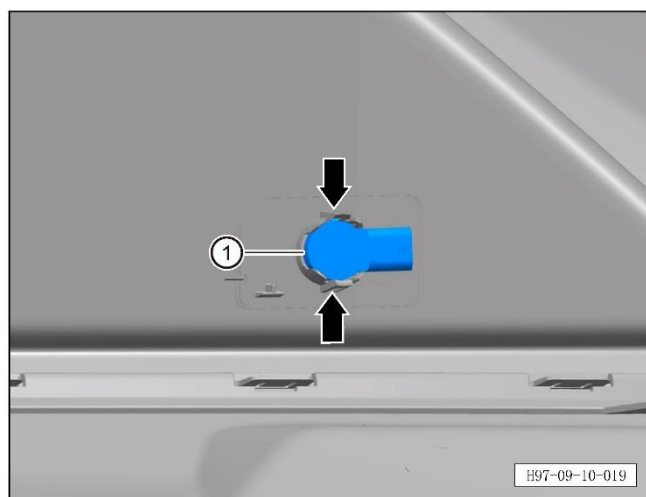

Refitting procedure

The refitting procedure is performed in reverse order.

9.10.3.6 Removal and refitting of parking radar sensor

Removal procedure

Note:

- The following is the removal and refitting of the front bumper left parking radar sensor, which can be referred to for other operations.

1. Turn off all electrical appliances and the start switch.

2. Disconnect the negative terminal of the battery (refer to [3.1.7.1 Maintenance and inspection of battery](#))

3. Remove the front bumper assembly (refer to [8.6.3.3 Removal and refitting of front bumper assembly](#))

4. Remove the front bumper left parking radar sensor.

a. Disconnect the connector of front bumper left parking radar sensor.

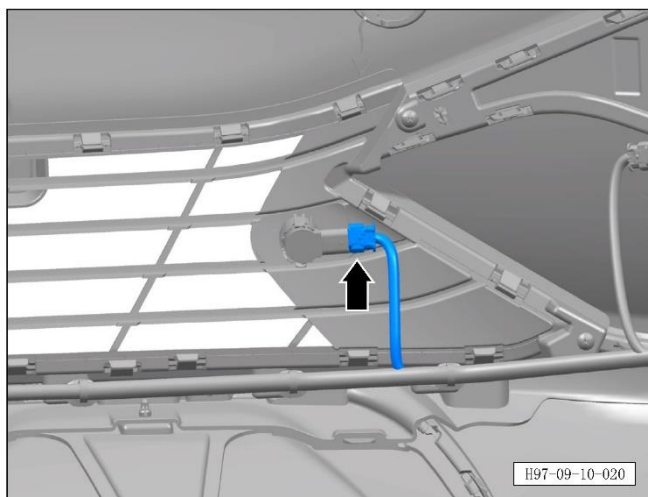

b. Take out 2 fixing clips of the front bumper left parking radar sensor, and take out the front bumper left parking radar sensor ①.

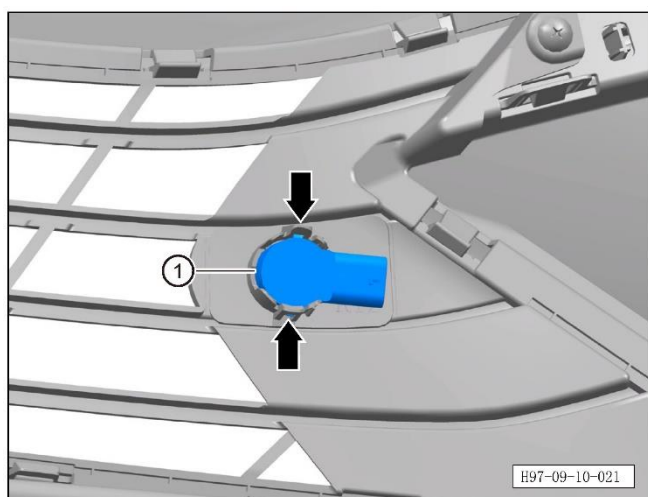

Refitting procedure

The refitting procedure is performed in reverse order.

9.10.3.7 Removal and refitting of RPA ECU

Removal procedure

1. Turn off all electrical appliances and the start switch.
2. Disconnect the negative terminal of the battery (refer to [3.1.7.1 Maintenance and inspection of battery](#))
3. Remove the front right seat assembly (refer to [8.1.3.1 Removal and refitting of front seat assembly](#))
4. Remove the RPA ECU.

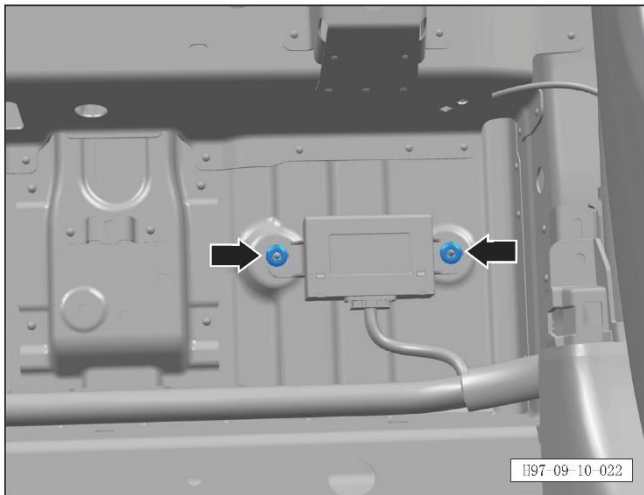

- a. Turn over the carpet and unscrew 2 fixing nuts of the RPA ECU.

Tightening torque of nut: $10\pm 2\text{Nm}$.

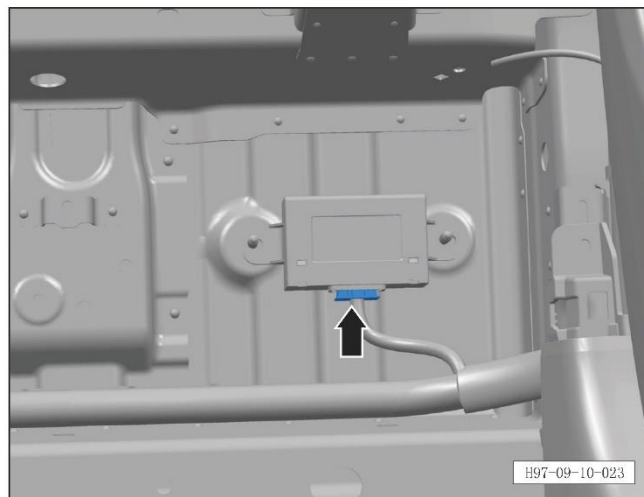

- b. Disconnect the connector of the RPA ECU.

Refitting procedure

The refitting procedure is performed in reverse order.

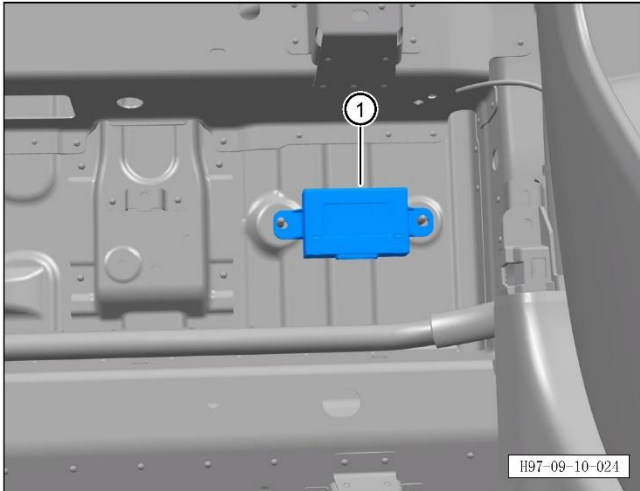

b. Take out the RPA ECU ①.

Refitting procedure

The refitting procedure is performed in reverse order.

9.10.3.8 Removal and refitting of APA ECU

Removal procedure

1. Turn off all electrical appliances and the start switch.
2. Disconnect the negative terminal of the battery (refer to [3.1.7.1 Maintenance and inspection of battery](#))
3. Remove the console assembly (refer to [8.3.4.22 Removal and refitting of console assembly](#))
4. Remove the APA ECU.

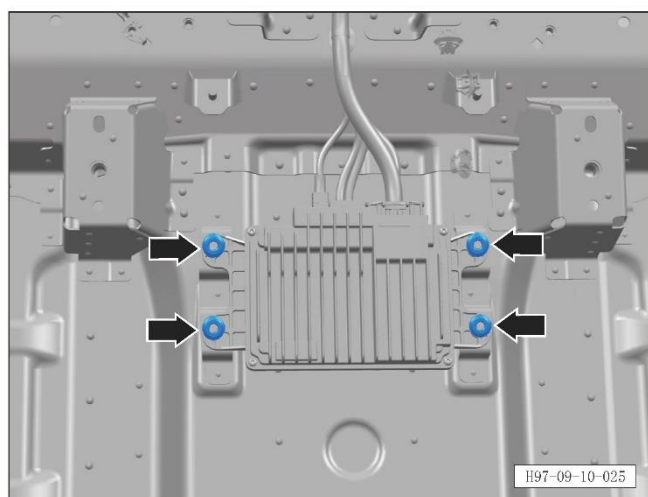

- a. Unscrew 2 fixing nuts of the APA ECU.
Tightening torque of nut: $10\pm 2\text{Nm}$.

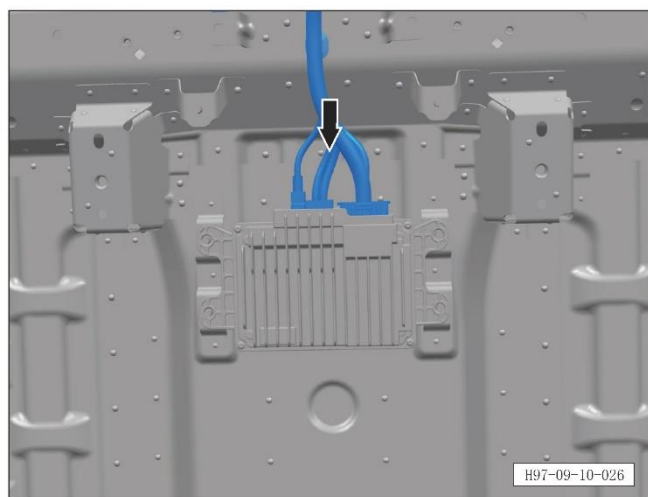

- b. Disconnect the connector of the APA ECU.

Refitting procedure

The refitting procedure is performed in reverse order.

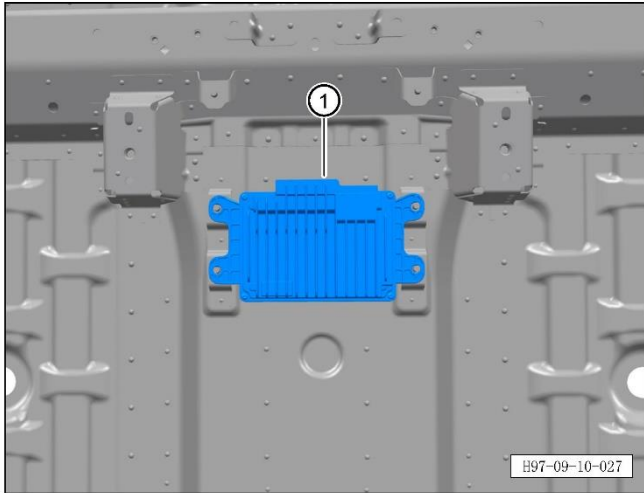

b. Take out the APA ECU ①.

Refitting procedure

The refitting procedure is performed in reverse order.

9.10.4 Image assist

9.10.4.1 Removal and refitting of FVC assembly

Removal procedure

1. Turn off all electrical appliances and the start switch.
2. Disconnect the negative terminal of the battery (refer to [3.1.7.1 Maintenance and inspection of battery](#))
3. Remove the front bumper assembly (refer to [8.6.3.3 Removal and refitting of front bumper assembly](#))
4. Remove the FVC assembly.
 - a. Disconnect the connector of the FVC assembly.

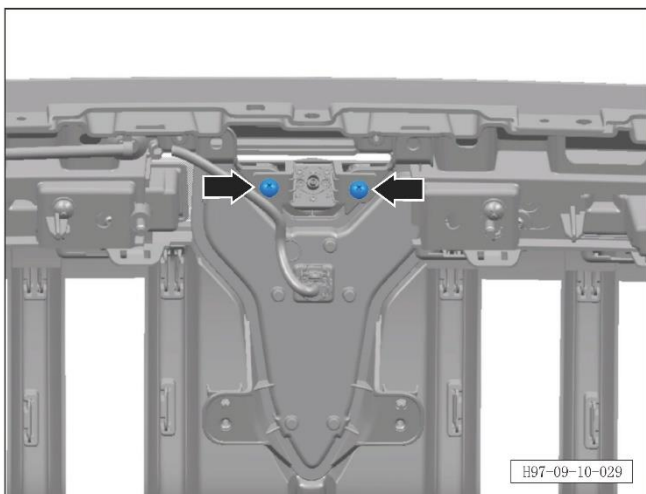
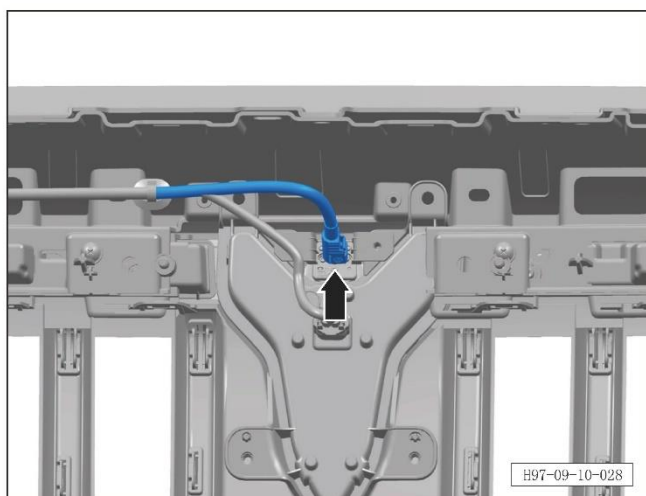

- b. Unscrew 2 fixing screws of the FVC assembly.
Tightening torque of screw: $2\pm 1\text{Nm}$

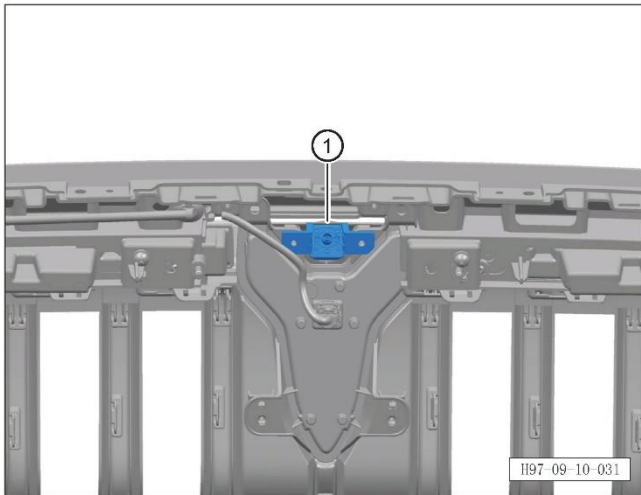

c. Remove the FVC assembly ①.

Refitting procedure

The refitting procedure is performed in reverse order.

9.10.4.2 Removal and refitting of FVC trim panel

Removal procedure

1. Turn off all electrical appliances and the start switch.
2. Disconnect the negative terminal of the battery (refer to [3.1.7.1 Maintenance and inspection of battery](#))
3. Remove the front bumper assembly (refer to [8.6.3.3 Removal and refitting of front bumper assembly](#))
4. Remove the FVC trim panel.

a. Unscrew 2 fixing screws of the FVC trim panel.

Tightening torque of screw: $2\pm 1\text{Nm}$

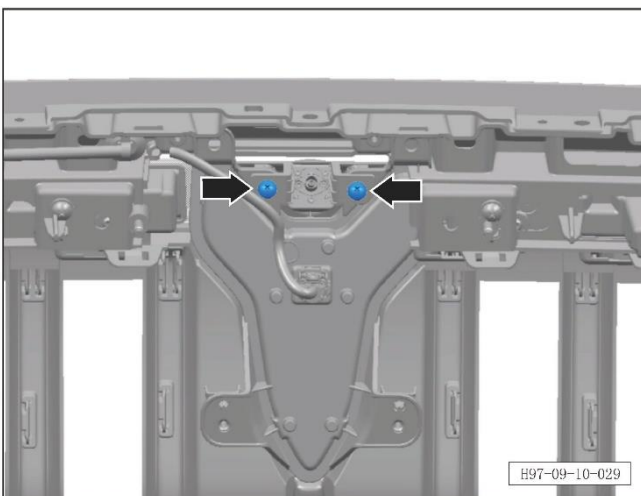

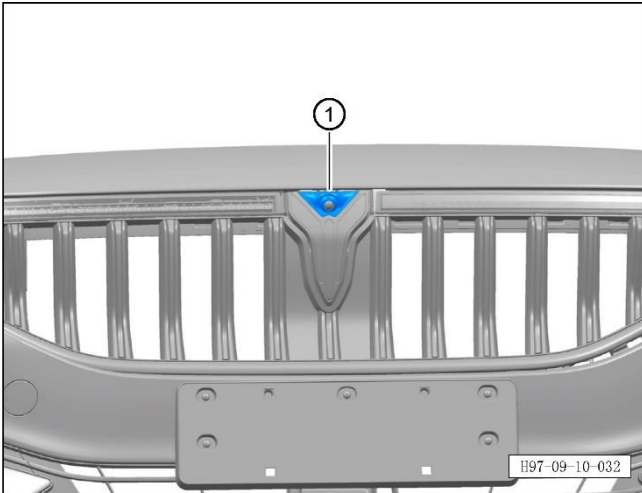

b. Remove the FVC trim panel ①.

Refitting procedure

The refitting procedure is performed in reverse order.

9.10.4.3 Removal and refitting of RVC assembly

Removal procedure

1. Turn off all electrical appliances and the start switch.
2. Disconnect the negative terminal of the battery (refer to [3.1.7.1 Maintenance and inspection of battery](#))
3. Remove the rear bumper assembly (refer to [8.6.3.10 Removal and refitting of rear bumper assembly](#))
4. Remove the RVC assembly.

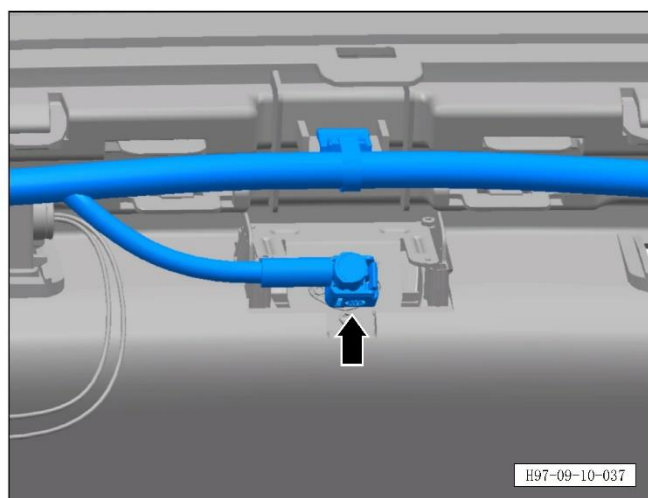

- a. Disconnect the connector of the RVC assembly.

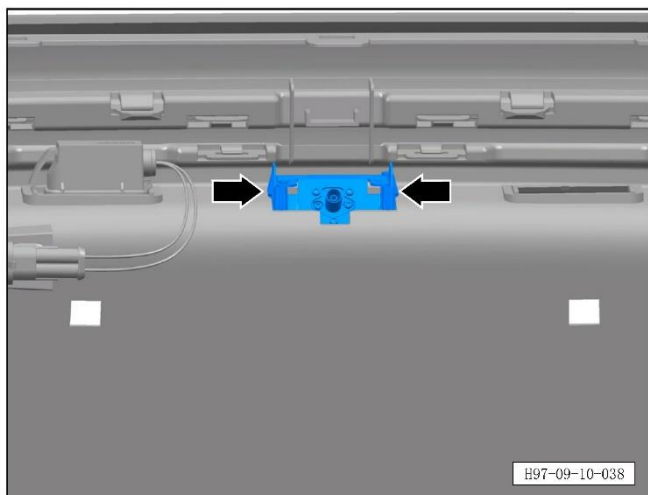

- b. Unscrew 2 fixing screws of the RVC assembly.
Tightening torque of screw: $2\pm 1\text{Nm}$

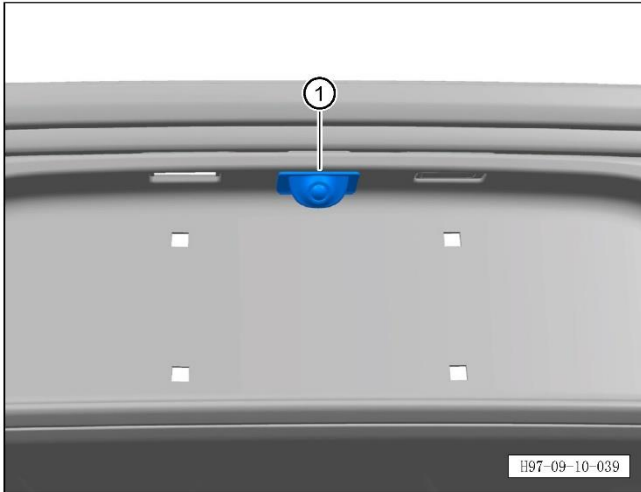

c. Remove the RVC assembly ①.

Refitting procedure

The refitting procedure is performed in reverse order.

9.10.4.4 Removal and refitting of AVM control unit assembly

Removal procedure

1. Turn off all electrical appliances and the start switch.
2. Disconnect the negative terminal of the battery (refer to [3.1.7.1 Maintenance and inspection of battery](#))
3. Remove the console assembly (refer to [8.3.4.22 Removal and refitting of console assembly](#))
4. Remove the AVM control unit assembly.

a. Unscrew 4 fixing nuts of the AVM control unit assembly.

Tightening torque of nut: $10\pm 2\text{Nm}$.

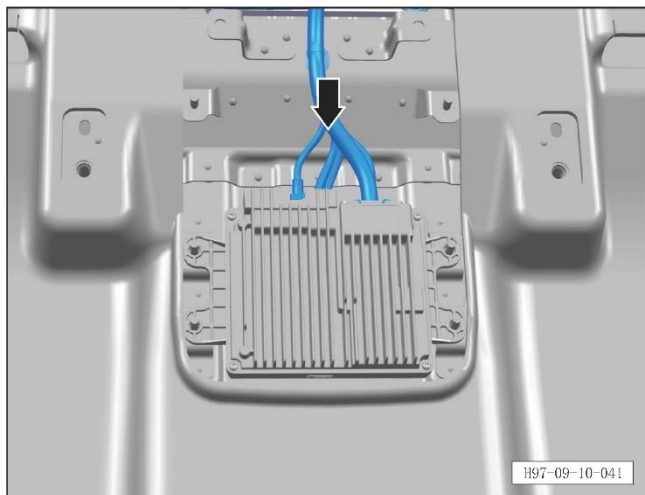
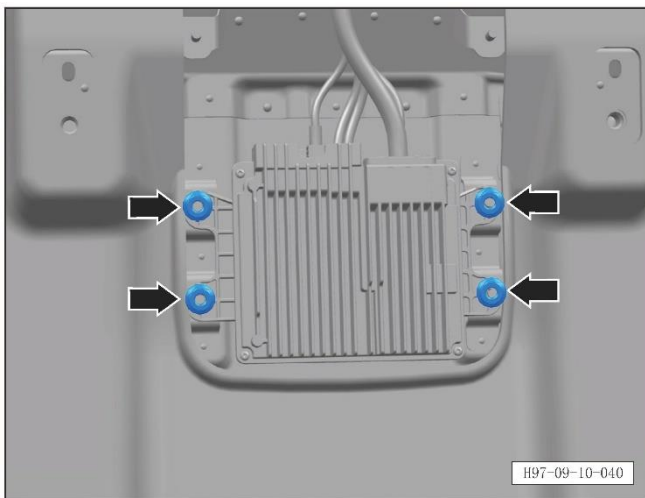

b. Disconnect the connector of the AVM control unit assembly.

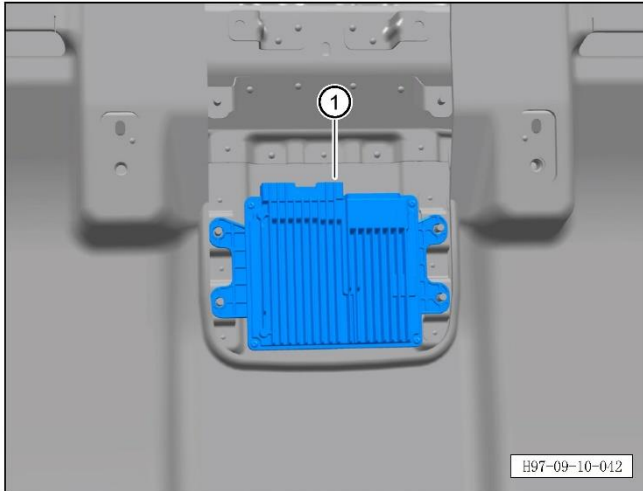

c. Take out the AVM control unit assembly ①.

Refitting procedure

The refitting procedure is performed in reverse order.

9.10.4.5 Removal and refitting of front view monocular camera

Removal procedure

1. Turn off all electrical appliances and the start switch.
2. Disconnect the negative terminal of the battery (refer to [3.1.7.1 Maintenance and inspection of battery](#))
3. Remove the interior rearview mirror front trim cover (refer to [8.6.8.7 Removal and refitting of interior rearview mirror front trim cover](#))
4. Remove the rear trim cover of interior rearview mirror (refer to [8.6.8.9 Removal and refitting of rear trim cover of interior rearview mirror](#))
5. Remove the front view monocular camera.

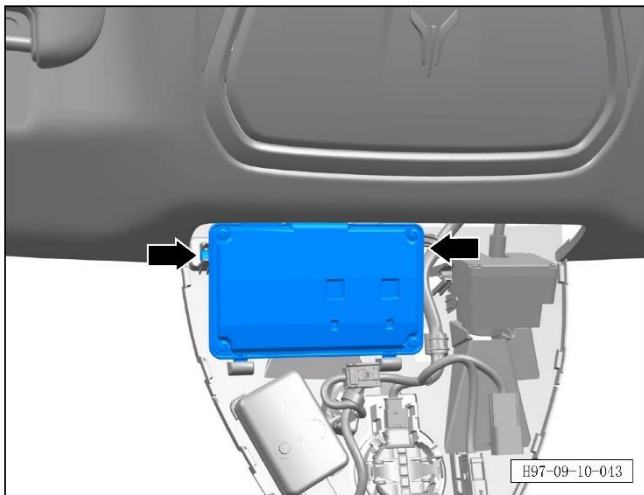

- a. Disengage 2 fixing clips of the front view monocular camera.

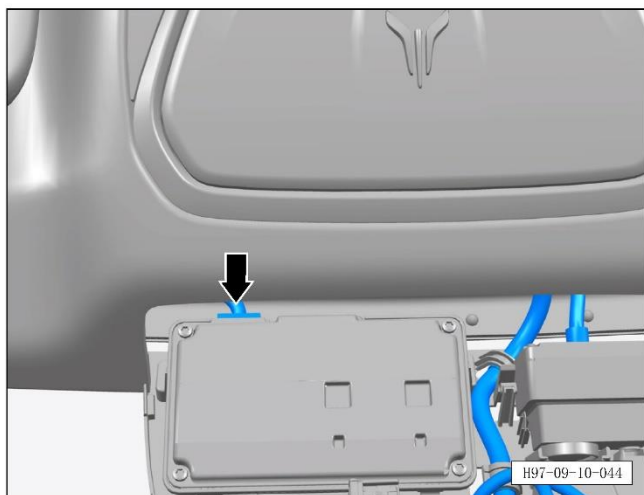

- b. Disconnect the connectors of the front view monocular camera.

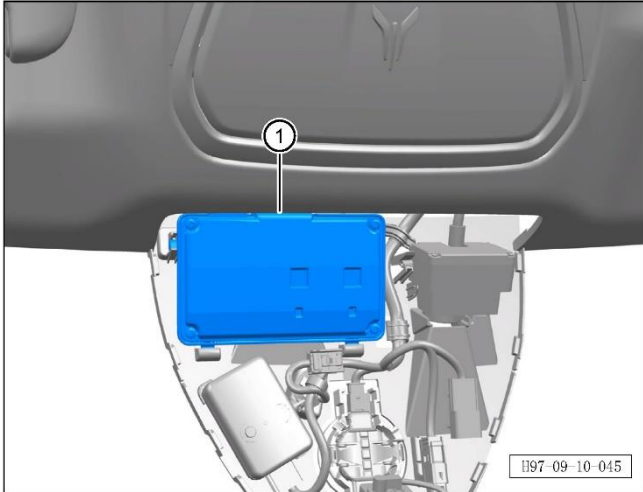

c. Take out the front view monocular camera ①.

Refitting procedure

The refitting procedure is performed in reverse order.